

ABB industrial drives

Hardware manual ACS880-31 drives



You can find manuals and other product documents in PDF format on the Internet. See section [Document library on the Internet](#) on the inside of the back cover. For manuals not available in the Document library, contact your local ABB representative. The codes below open an online listing of the manuals applicable to the product.



[ACS880-31 manuals](#)

Hardware manual

ACS880-31 drives

Table of contents



1. Safety instructions



4. Mechanical installation



6. Electrical installation –
IEC



7. Electrical installation –
USA



Update notice

The notice concerns the ACS880-31 hardware manual given below.

Contents of the notice: New values for ratings, fuses and sine filters.

Code of this notice: 3AXD50000335350 Rev A. **Valid:** From 2018-10-15 until revision D of the manual.

Manual code	Revision	Language	
3AXD50000045933	C	English	EN

Ratings

Changed:

Type ACS880 -31-	Frame size	Input rating	Max. current	App. power	Output ratings					
					Nominal use		Light-duty use		Heavy-duty use	
					I_2	P_N	I_{Ld}	P_{Ld}	I_{Hd}	P_{Hd}
		A	A	kVA	A	kW	A	kW	A	kW
3-phase $U_N = 500$ V										
07A6-5	R3	5.8	9.5	6.6	7.6	4.0	7.2	4.0	5.2	2.2
11A0-5	R3	7.8	13.8	9.5	11.0	5.5	10.4	5.5	7.6	4.0
014A-5	R3	10.6	18.7	12	14	7.5	13	7.5	11.0	5.5
021A-5	R3	15.6	26.3	18	21	11.0	19	11.0	14	7.5
027A-5*	R6	21.3	35.7	23	27	15.0	26	15.0	21	11.0
034A-5*	R6	26.2	45.9	29	34	18.5	32	18.5	27	15.0
040A-5*	R6	31.2	57.8	35	40	22.0	38	22.0	34	18.5
052A-5*	R6	40.1	68.0	45	52	30.0	49	30.0	40	22.0
065A-5*	R6	49.5	88.4	56	65	37.0	62	37.0	52	30.0
077A-5*	R6	60.2	110.5	67	77	45.0	73	45.0	65	37.0
101A-5	R8	71	148	87	101	45.0	91	45	77	37.0
124A-5	R8	96	178	107	124	55.0	118	55	96	45.0
156A-5	R8	115	247	137	156	75.0	148	75	124	55.0
180A-5	R8	141	287	156	180	90.0	171	90	156	75.0

Fuses

Changed:

Type ACS880 -31-	Min. short- circuit current ¹⁾	Input current	aR				
			Nominal current	I^2t	Voltage rating	Bussmann type	IEC 60269 size
3-phase $U_N = 500$ V							
07A6-5	65	5.8	25	130	690	170M1561	000
11A0-5	65	7.8	25	130	690	170M1561	000
014A-5	120	10.6	40	460	690	170M1563	000

2 Update notice

Type ACS880 -31-	Min. short-circuit current ¹⁾	Input current	aR				
			Nominal current	I^2t	Voltage rating	Bussmann type	IEC 60269 size
			A	A ² s	V		
021A-5	120	15.6	40	460	690	170M1563	000
027A-5	170	21.3	63	1450	690	170M1565	000
034A-5	170	26.2	63	1450	690	170M1565	000
040A-5	280	31.2	80	2550	690	170M1566	000
052A-5	300	40.1	100	4650	690	170M1567	000
065A-5	480	49.5	125	8500	690	170M1568	000
077A-5	700	60.2	160	16000	690	170M1569	000
101A-5	1000	71	250	28500	690	170M3816	1
124A-5	1280	96	315	46500	690	170M3817	1
156A-5	1610	115	400	74000	690	170M5808	2
180A-5	2210	141	500	155000	690	170M5810	2

¹⁾ Minimum short-circuit current of the installation

Type ACS880 -31-	Min. short-circuit current ¹⁾	Input current	gG (IEC 60269)				
			Nominal current	I^2t	Voltage rating	ABB type	IEC 60269 size
			A	A ² s	V		
3-phase $U_N = 500$ V							
07A6-5	120	5.8	16	700	500	OFAF000H16	000
11A0-5	120	7.8	16	700	500	OFAF000H16	000
014A-5	200	10.6	25	2500	500	OFAF000H25	000
021A-5	250	15.6	32	4500	500	OFAF000H32	000
027A-5	350	21.3	40	7700	500	OFAF000H40	000
034A-5	400	26.2	50	15400	500	OFAF000H50	000
040A-5	500	31.2	63	21300	500	OFAF000H63	000
052A-5	800	40.1	80	37000	500	OFAF000H80	000
065A-5	1000	49.5	100	63600	500	OFAF000H100	000
077A-5	1000	60.2	100	63600	500	OFAF000H100	000

¹⁾ Minimum short-circuit current of the installation

Type ACS880 -31-	Input current	UL (one fuse per phase)			
		Nominal current	Voltage rating	Bussmann type	UL class
		A	V		
3-phase $U_N = 480$ V					
07A6-5	5.8	15	600	JJS-15	T
11A0-5	7.8	20	600	JJS-20	T
014A-5	10.6	25	600	JJS-25	T
021A-5	15.6	35	600	JJS-35	T
027A-5	21.3	40	600	JJS-40	T
034A-5	26.2	50	600	JJS-50	T
040A-5	31.2	60	600	JJS-60	T
052A-5	40.1	80	600	JJS-80	T
065A-5	49.5	90	600	JJS-90	T

Type ACS880 -31-	Input current	UL (one fuse per phase)			
		Nominal current	Voltage rating	Bussmann type	UL class
		A	V		
077A-5	60.2	110	600	JJS-110	T
101A-5	74	150	600	JJS-150	T
124A-5	100	200	600	JJS-200	T
156A-5	120	225	600	JJS-225	T
180A-5	147	300	600	JJS-300	T

Sine filter

Changed:

Type ACS880 -31-	Sine filter type	$I_{cont.}$ max A	$P_{cont.}$ max kW	Heat dissipation			Noise dB(A)
				Drive W	Filter W	Total W	
				$U_N = 400\text{ V}$			
09A4-3	B84143V0011R229	10,0	4,0	226	90	316	72
12A6-3	B84143V0016R229	12,9	5,5	329	80	409	72
017A-3	B84143V0025R229	17	7,5	395	140	535	75
025A-3	B84143V0025R229	25	11,0	579	140	719	75
032A-3	B84143V0033R229	32	15,0	625	160	785	75
038A-3	B84143V0050R229	38	18,5	751	220	971	78
045A-3	B84143V0050R229	45	22,0	912	220	1132	78
061A-3	B84143V0066R229	61	30,0	1088	250	1338	78
072A-3	B84143V0075R229	72	37,0	1502	310	1812	79
087A-3	B84143V0095R229	87	45,0	1904	400	2304	79
105A-3	B84143V0130S230	105	55,0	1877	600	2477	80
145A-3	B84143V0162S229	145	75,0	2963	550	3513	80
169A-3	B84143V0162S229	169	90,0	3168	550	3718	80
206A-3	B84143V0230S229	206	110,0	3990	900	4890	80
$U_N = 500\text{ V}$							
07A6-5	B84143V0011R229	7,6	4,0	219	90	309	72,0
11A0-5	B84143V0011R229	11,0	5,5	278	90	368	72,0
014A-5	B84143V0016R229	14	7,5	321	80	401	70
021A-5	B84143V0025R229	21	11,0	473	140	613	75
027A-5	B84143V0033R229	27	15,0	625	160	785	75
034A-5	B84143V0050R229	34	18,5	711	220	931	78
040A-5	B84143V0050R229	40	22,0	807	220	1027	78
052A-5	B84143V0066R229	52	30,0	960	250	1210	78
065A-5	B84143V0066R229	65	37,0	1223	250	1473	78
077A-5	B84143V0075R229	77	37,0	1560	310	1870	78
101A-5	B84143V0130S230	96	55,0	1995	630	2625	80
124A-5	B84143V0130S230	124	55,0	2800	630	3430	80
158A-5	B84143V0162S229	156	90,0	3168	550	3718	80
180A-5	B84143V0162S229	180	110,0	3872	550	4422	80

4 *Update notice*

Table of contents

1. Safety instructions

Contents of this chapter	13
Use of warnings and notes in this manual	13
General safety in installation, start-up and maintenance	14
Electrical safety in installation, start-up and maintenance	16
Precautions before electrical work	16
Additional instructions and notes	17
Grounding	18
Additional instructions for permanent magnet motor drives	19
Safety in installation, start-up and maintenance	19
General safety in operation	20
Additional instruction for DC connection	20

2. Introduction to the manual

Contents of this chapter	21
Applicability	21
Target audience	21
Purpose of the manual	21
Categorization by frame (size)	21
Quick installation and commissioning flowchart	22
Terms and abbreviations	22
Related documents	24

3. Operation principle and hardware description

Contents of this chapter	27
Operation principle	28
DC connection	28
Layout	29
Overview of power and control connections	33
Control panel	34
Type designation label	35
Type designation key	36

4. Mechanical installation

Contents of this chapter	39
Safety	39
Examining the installation site	40
Required tools	43
Moving the drive	43
Unpacking and examining delivery	44
Installing the drive	49
Flange mounting (option +C135)	50



Cabinet installation (option +P940) 50

5. Guidelines for planning the electrical installation

Contents of this chapter 51

Selecting the supply disconnecting device 51

 European Union 51

 North American Market 52

 Other regions 52

Checking the compatibility of the motor and drive 52

 Protecting the motor insulation and bearings 52

 Requirements table 53

 Additional requirements for ABB motors of types other than M2_, M3_, M4_, HX_ and AM_ 55

 Additional requirements for ABB high-output and IP23 motors 56

 Additional requirements for non-ABB high-output and IP23 motors 56

 Additional data for calculating the rise time and peak line-to-line voltage 57

 Additional note for sine filters 59

Selecting the power cables 59

 General rules 59

 Typical power cable sizes 60

 Alternative power cable types 61

 Recommended power cable types 61

 Power cable types for limited use 62

 Not allowed power cable types 62

 Motor cable shield 62

 Additional US requirements 63

 Conduit 63

 Armored cable / shielded power cable 63

Selecting the control cables 63

 Shielding 63

 Signals in separate cables 64

 Signals allowed to be run in the same cable 64

 Relay cable 64

 Control panel cable 64

 Drive composer PC tool cable 64

Routing the cables 65

 General rules 65

 Separate control cable ducts 66

 Continuous motor cable shield or enclosure for equipment on the motor cable 66

Implementing thermal overload and short-circuit protection 67

 Protecting the drive and input power cable in short-circuits 67

 Protecting the motor and motor cable in short-circuits 67

 Protecting the drive and the input power and motor cables against thermal overload ... 67

 Protecting the motor against thermal overload 67

Protecting the drive against ground faults 68

 Residual current device compatibility 68

Implementing the Emergency stop function 68

Implementing the Safe torque off function 68

Implementing the safety functions provided with the FSO safety functions module (options +Q972 and +Q973) 68



Declaration of Conformity	69
Implementing the ATEX-certified Safe motor disconnection function (option +Q971)	69
Implementing the undervoltage control (power-loss ride-through)	69
Using a safety switch between the drive and the motor	69
Using a contactor between the drive and the motor	70
Protecting the contacts of relay outputs	70
Implementing a motor temperature sensor connection	72
Connection of motor temperature sensor to the drive via an option module	73
Connection of motor temperature sensor to the drive via a relay	74

6. Electrical installation – IEC

Contents of this chapter	75
Warnings	75
Required tools	75
Grounding the motor cable shield at the motor end	76
Checking the insulation of the assembly	76
Drive	76
Input power cable	76
Motor and motor cable	76
Brake resistor assembly	77
Checking the compatibility with IT (ungrounded), corner-grounded delta, midpoint-grounded delta, and TT systems	78
EMC filter option +E200 or +E202	78
Ground-to-phase varistor	78
When to disconnect EMC filter (options E200 and +E202) or ground-to-phase varistor: TN-S, IT, corner-grounded delta, and midpoint-grounded delta systems	79
Guidelines for installing the drive to a TT system	80
Identifying different types of electrical power systems	80
Disconnecting internal EMC filter (option +E200 or +E202) and ground-to-phase varistor – frame R3	82
Disconnecting internal EMC filter (option +E200 or +E202) and ground-to-phase varistor – frame R6	83
Disconnecting internal EMC filter and ground-to-phase varistor –frame R8	84
Connecting the power cables	85
Connection diagram	85
Connection procedure	86
R8 power cable connection if you detach the motor cable connectors	95
Connecting the control cables	96
Default I/O connection diagram	97
Notes:	98
Jumpers and switches	98
AI1 and AI2 as Pt100, Pt1000, PTC and KTY84 sensor inputs (XAI, XAO)	99
External power supply for the control unit (XPOW)	99
Drive-to-drive link (XD2D)	100
DIIL input (XD24:1)	100
DI6 (XDI:6) as PTC sensor input	101
Safe torque off (XSTO)	101
Safety functions module connection (X12)	101
Control cable connection procedure (IEC)	101
Installing option modules	106



8 Table of contents

Mechanical installation of option modules	106
Wiring option modules	107
Installation of safety functions modules	108
Installation procedure into Slot 2	108
Installation next to the control unit on frames R6 and R8	110
Reinstalling cover(s)	112
Connecting a PC	113
Controlling several drives through the panel bus	114

7. Electrical installation – USA

Contents of this chapter	117
Warnings	117
Required tools	117
Checking the insulation of the assembly	117
Drive	117
Input power cable	118
Motor and motor cable	118
Brake resistor assembly	118
Checking the compatibility with IT (ungrounded), corner-grounded and midpoint-grounded delta systems, and TT systems	119
Connecting the power cables	120
Connection diagram	120
Connection procedure	121
R8 motor cable connection if you detach the connectors	130
Connecting the control cables	131
Default I/O connection diagram	132
Notes:	133
Jumpers and switches	133
AI1 and AI2 as Pt100, Pt1000, PTC and KTY84 sensor inputs (XAI, XAO)	134
External power supply for the control unit (XPOW)	134
Drive-to-drive link (XD2D)	135
DIIL input (XD24:1)	135
DI6 (XDI:6) as PTC sensor input	136
Safe torque off (XSTO)	136
Safety functions module connection (X12)	136
Control cable connection procedure	136
Installing option modules	141
Reinstalling cover(s)	141
Connecting a PC	141
Controlling several drives through the panel bus	142

8. Installation checklist

Contents of this chapter	143
Warnings	143
Checklist	143

9. Start-up

Contents of this chapter	145
--------------------------------	-----



Start-up procedure	145
--------------------------	-----

10. Maintenance and hardware diagnostics

Contents of this chapter	147
Maintenance intervals	147
Description of symbols	148
Recommended annual maintenance actions by the user	148
Recommended maintenance actions by the user	148
Heatsink	149
Fans	149
Replacing the main cooling fan, frame R3	150
Replacing the main cooling fan, frame R6	151
Replacing the main cooling fan, frame R8	152
Replacing the auxiliary cooling fan, IP55 (UL Type 12) frame R3	153
Replacing the auxiliary cooling fan, frame R6	154
Replacing the auxiliary cooling fan, frame R8	155
Replacing the second auxiliary cooling fan IP55 (UL Type 12), frame R8	156
Capacitors	158
Reforming the capacitors	158
Memory unit	158
Replacing the memory unit	159
Replacing the control unit battery	159
Control panel	160
Cleaning the control panel	160
Replacing the battery in the control panel	160
LEDs	161
Drive LEDs	161
Control panel LEDs	161



11. Technical data

Contents of this chapter	163
Ratings	163
IEC ratings	163
UL (NEC) ratings	164
Definitions	165
Sizing	165
Derating	165
Ambient temperature derating, IP21 (UL Type 1)	166
Ambient temperature derating, IP55 (UL Type 12)	167
Ambient temperature derating in table format	168
Deratings for special settings in the drive control program	169
High speed mode	172
Altitude derating	173
Fuses (IEC)	174
aR fuses	174
gG fuses	175
Quick guide for selecting between gG and aR fuses	175
Calculating the short-circuit current of the installation	176
Fuses (UL)	178

10 Table of contents

Dimensions, weights and free space requirements	179
Free space requirements	179
Losses, cooling data and noise	180
Terminal and entry data for the power cables	181
IEC	181
UL	181
UL listed cable lugs and tools	182
Terminal and entry data for the control cables	182
IEC	182
US	183
Electrical power network specification	183
Voltage (U1)	183
Motor connection data	184
Control unit (ZCU-12) connection data	185
Efficiency	189
Degree of protection	189
Materials	189
Applicable standards	191
Ambient conditions	192
CE marking	193
Compliance with the European Low Voltage Directive	193
Compliance with the European EMC Directive	193
Compliance with the European ROHS II Directive	194
Compliance with the European WEEE Directive	194
Compliance with the European Machinery Directive	194
Declaration of conformity	195
Compliance with the EN 61800-3:2004 + A1:2012	197
Definitions	197
Category C2	197
Category C3	198
Category C4	199
UL marking	200
UL checklist	200
RCM marking	201
China RoHS marking	201
EAC marking	201
Disclaimers	202
General disclaimer	202
Cybersecurity disclaimer	202

12. Dimension drawings

Contents of this chapter	203
R3, IP21 (UL Type 1)	204
R3 – Option +B056 (IP55, UL Type 12)	205
R6, IP21 (UL Type 1)	206
R6 – Option +B054 (IP55, UL Type 12)	207
R6 – Option +B056 (IP55, UL Type 12)	208
R8 – Option +B056 (IP55, UL Type 12)	211

13. The Safe torque off function

Contents of this chapter	213
Description	213
Compliance with the European Machinery Directive	214
Wiring	214
Single drive (internal power supply)	215
Multiple drives (internal power supply)	216
Multiple drives (external power supply)	217
Wiring examples	218
Activation switch	218
Cable types and lengths	218
Grounding of protective shields	218
Operation principle	218
Start-up including acceptance test	219
Competence	219
Acceptance test reports	219
Acceptance test procedure	219
Use	221
Maintenance	222
Competence	222
Fault tracing	222
Safety data (SIL, PL)	223
Abbreviations	224



14. Resistor braking

Contents of this chapter	225
Operation principle and hardware description	225
Planning the braking system	225
Selecting the brake circuit components	225
Selecting a custom resistor	226
Selecting and routing the brake resistor cables	226
Minimizing electromagnetic interference	227
Maximum cable length	227
EMC compliance of the complete installation	227
Placing the brake resistors	227
Protecting the system against thermal overload	228
Protecting the system in fault situations	228
Protecting the resistor cable against short-circuits	228
Mechanical installation	229
Electrical installation	229
Checking the insulation of the assembly	229
Connection diagram	229
Connection procedure	229
Start-up	229
Technical data	230
Ratings	230
Terminals and cable lead-through data	230

15. Common mode, du/dt and sine filters

Contents of this chapter	231
Common mode filters	231
When is a common mode filter needed?	231
du/dt filters	231
When is a du/dt filter needed?	231
du/dt filter types	232
Description, installation and technical data of the NOCH filters	232
Sine filters	232
Selecting a sine filter for the drive	232
Definitions	233
Derating	233
Description, installation and technical data	234

Further information

Product and service inquiries	235
Product training	235
Providing feedback on ABB Drives manuals	235
Document library on the Internet	235



1

Safety instructions

Contents of this chapter

This chapter contains the safety instructions which you must obey when you install and operate the drive and do maintenance on the drive. If you ignore the safety instructions, injury, death or damage can occur.

Use of warnings and notes in this manual

Warnings tell you about conditions which can cause injury or death, or damage to the equipment. They also tell you how to prevent the danger. Notes draw attention to a particular condition or fact, or give information on a subject.

The manual uses these warning symbols:



Electricity warning tells about hazards from electricity which can cause injury or death, or damage to the equipment.



General warning tells about conditions, other than those caused by electricity, which can cause injury or death, or damage to the equipment.



Electrostatic sensitive devices warning tells you about the risk of electrostatic discharge which can cause damage to the equipment.



General safety in installation, start-up and maintenance

These instructions are for all personnel that install the drive and do maintenance work on it.

 **WARNING!** Obey these instructions. If you ignore them, injury or death, or damage to the equipment can occur.

- Use safety shoes with a metal toe cap to avoid foot injury. Wear protective gloves and long sleeves. Some parts have sharp edges.
- Handle the drive carefully.
 - Lift the drive with a lifting device. Use the lifting eyes of the drive.
 - Do not tilt the drive. The drive is heavy and its center of gravity is high. It will overturn easily.

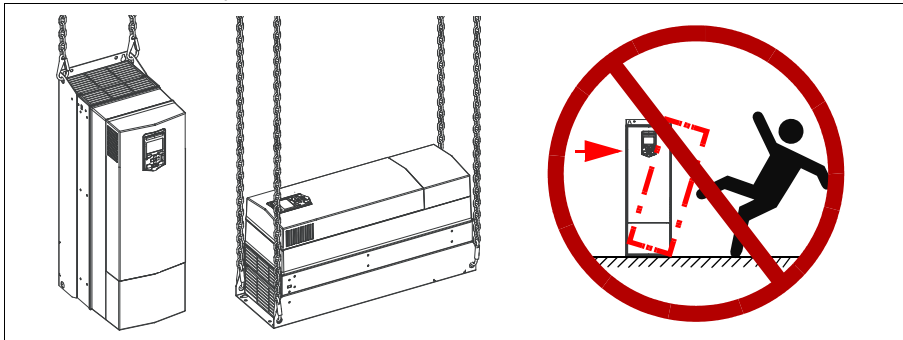

- Beware of hot surfaces. Some parts, such as heatsinks of power semiconductors, remain hot for a while after disconnection of the electrical supply.
- Keep the drive in its package or protect it from dust and metal shavings from drilling and grinding until you install it. Protect the installed drive against dust and metal shavings. Electrically conductive debris inside the drive can cause damage or malfunction.
- Vacuum clean the area below the drive before the start-up to prevent the drive cooling fan from drawing the dust inside the drive.
- Do not cover the air inlet and outlet when the drive runs.
- Make sure that there is sufficient cooling. See sections [Examining the installation site](#) on page 40 and [Losses, cooling data and noise](#) on page 180 for more information.
- Before you connect voltage to the drive, make sure that the drive covers are on. Keep the covers on during the operation.
- Before you adjust the drive operation limits, make sure that the motor and all driven equipment can operate throughout the set operation limits.
- Before you activate the automatic fault reset or automatic restart functions of the drive control program, make sure that no dangerous situations can occur. These

functions reset the drive automatically and continue operation after a fault or supply break. If these functions are activated, the installation must be clearly marked as defined in IEC/EN 61800-5-1, subclause 6.5.3, for example, "THIS MACHINE STARTS AUTOMATICALLY".

- The maximum number of drive power-ups is five in ten minutes. Too frequent power-ups can damage the charging circuit of the DC capacitors.
- Make sure that any safety circuits (for example, emergency stop and Safe torque off) are validated at start-up. For the Safe torque off, see chapter [The Safe torque off function](#) page 213. For other safety functions, see their separate instructions..

Note:

- If you select an external source for the start command and it is on, the drive will start immediately after fault reset unless you configure the drive for pulse start. See the firmware manual.
 - Depending on the wiring and parametrization of the drive, the stop key on the control panel may not stop the drive.
 - Only authorized persons are allowed to repair a malfunctioning drive.
-



Electrical safety in installation, start-up and maintenance

■ Precautions before electrical work

These warnings are for all personnel who do work on the drive, motor cable or motor.

 **WARNING!** Obey these instructions. If you ignore them, injury or death, or damage to the equipment can occur. If you are not a qualified electrical professional, do not do electrical installation or maintenance work. Go through these steps before you begin any installation or maintenance work.

1. Clearly identify the work location.
 2. Disconnect all possible voltage sources. Lock and tag.
 - Open the main disconnecter at the power supply of the drive.
 - Make sure that reconnection is not possible.
 - Disconnect any external power sources from the control circuits.
 - After you disconnect the drive, always wait for 5 minutes to let the intermediate circuit capacitors discharge before you continue.
 3. Protect any other energized parts in the work location against contact.
 4. Take special precautions when close to bare conductors.
 5. Measure that the installation is de-energized.
 - Use a multimeter with an impedance of at least 1 Mohm.
 - Make sure that the voltage between the drive input power terminals (L1, L2, L3) and the grounding terminal (PE) is close to 0 V.
 - Make sure that the voltage between the drive DC terminals (UDC+ and UDC-) and the grounding terminal (PE) is close to 0 V.
 6. Install temporary grounding as required by the local regulations.
 7. Ask for a permit to work from the person in control of the electrical installation work.
-

Additional instructions and notes



WARNING! Obey these instructions. If you ignore them, injury or death, or damage to the equipment can occur.

- A drive with EMC filter options +E200 and +E202 connected can be installed to a symmetrically grounded TN-S system. If you install the drive to another system, check if you must disconnect the EMC filter. See sections [When to disconnect EMC filter \(options E200 and +E202\) or ground-to-phase varistor: TN-S, IT, corner-grounded delta, and midpoint-grounded delta systems](#) on page 79 and [Guidelines for installing the drive to a TT system](#) on page 80.



WARNING! Do not install the drive with EMC filter options +E200 and +E202 connected to a system that the filter is not suitable for. This can cause danger, or damage the drive.

Note: When EMC filter +E200 and +E202 is disconnected, the drive EMC compatibility is considerably reduced.

- A drive with the ground-to-phase varistor connected can be installed to a symmetrically grounded TN-S system. If you install the drive to another system, check if you must disconnect the varistor. See sections [When to disconnect EMC filter \(options E200 and +E202\) or ground-to-phase varistor: TN-S, IT, corner-grounded delta, and midpoint-grounded delta systems](#) on page 79 and [Guidelines for installing the drive to a TT system](#) on page 80.



WARNING! Do not install the drive with the ground-to-phase varistor connected to a system that the varistor is not suitable for. If you do, the varistor circuit can be damaged.

- Do not do insulation or voltage withstand tests on the drive or drive modules.

Note:

- The motor cable terminals of the drive are at a dangerous voltage when the input power is on, regardless of whether the motor is running or not.
- The DC terminals (UDC+, UDC-) are at a dangerous voltage.
- External wiring can supply dangerous voltages to the terminals of relay outputs (XRO1, XRO2 and XRO3).
- The Safe torque off function does not remove the voltage from the main and auxiliary circuits. The function is not effective against deliberate sabotage or misuse.



WARNING! Use a grounding wrist band when you handle the printed circuit boards. Do not touch the boards unnecessarily. The boards contain components sensitive to electrostatic discharge.

■ Grounding

These instructions are for all personnel who are responsible for the electrical installation, including the grounding of the drive.



WARNING! Obey these instructions. If you ignore them, injury or death, or equipment malfunction can occur, and electromagnetic interference can increase.

- If you are not a qualified electrical professional, do not do grounding work.
- Always ground the drive, the motor and adjoining equipment to the protective earth (PE) bus of the power supply. This is necessary for the personnel safety. Proper grounding also reduces electromagnetic emission and interference.
- In a multiple-drive installation, connect each drive separately to the protective earth (PE) bus of the power supply.
- Make sure that the conductivity of the protective earth (PE) conductors is sufficient. See section [Selecting the power cables](#) on page 59. Obey the local regulations.
- Connect the power cable shields to the protective earth (PE) terminals of the drive.
- Make a 360° grounding of the power and control cable shields at the cable entries to suppress electromagnetic disturbances.

Note:

- You can use power cable shields as grounding conductors only when their conductivity is sufficient.
 - Standard IEC/EN 61800-5-1 (section 4.3.5.5.2.) requires that as the normal touch current of the drive is higher than 3.5 mA AC or 10 mA DC, you must use a fixed protective earth (PE) connection. In addition,
 - install a second protective earth conductor of the same cross-sectional area as the original protective earthing conductor,or
 - install a protective earth conductor with a cross-section of at least 10 mm² Cu or 16 mm² Al,or
 - install a device which automatically disconnects the supply if the protective earth conductor breaks.
-

Additional instructions for permanent magnet motor drives

■ Safety in installation, start-up and maintenance

These are additional warnings concerning permanent magnet motor drives. The other safety instructions in this chapter are also valid.



WARNING! Obey these instructions. If you ignore them, injury or death and damage to the equipment can occur.

- Do not work on a drive when a rotating permanent magnet motor is connected to it. A rotating permanent magnet motor energizes the drive including its input power terminals.

Before installation, start-up and maintenance work on the drive:

- Stop the motor.
- Disconnect the motor from the drive with a safety switch or by other means.
- If you cannot disconnect the motor, make sure that the motor cannot rotate during work. Make sure that no other system, like hydraulic crawling drives, can rotate the motor directly or through any mechanical connection like felt, nip, rope, etc.
- Measure that the installation is de-energized.
 - Use a multimeter with an impedance of at least 1 Mohm.
 - Make sure that the voltage between the drive output terminals (T1/U, T2/V, T3/W) and the grounding (PE) busbar is close to 0 V.
 - Make sure that the voltage between the drive input power terminals (L1, L2, L3) and the grounding (PE) busbar is close to 0 V.
 - Make sure that the voltage between the drive DC terminals (UDC+, UDC-) and the grounding (PE) terminal is close to 0 V.
- Install temporary grounding to the drive output terminals (T1/U, T2/V, T3/W). Connect the output terminals together as well as to the PE.

Start-up and operation:

- Make sure that the operator cannot run the motor over the rated speed. Motor overspeed causes overvoltage that can damage or destroy the capacitors in the intermediate circuit of the drive.



General safety in operation

These instructions are for all personnel that operate the drive.



WARNING! Obey these instructions. If you ignore them, injury or death, or damage to the equipment can occur.

- Do not control the motor with the disconnecter at the drive power supply; instead, use the control panel start and stop keys or commands through the I/O terminals of the drive.
- Give a stop command to the drive before you reset a fault. If you have an external source for the start command and the start is on, the drive will start immediately after the fault reset, unless you configure the drive for pulse start. See the firmware manual.
- Before you activate automatic fault reset functions of the drive control program, make sure that no dangerous situations can occur. These functions reset the drive automatically and continue operation after a fault.

Note: When the control location is not set to Local, the stop key on the control panel will not stop the drive.



Additional instruction for DC connection



WARNING! Do not connect the drive DC link to a common DC system. The drive will get damaged.

2

Introduction to the manual

Contents of this chapter

The chapter describes applicability, target audience and purpose of this manual. It describes the contents of this manual and refers to a list of related manuals for more information. The chapter also contains a flowchart of steps for checking the delivery, installing and commissioning the drive. The flowchart refers to chapters/sections in this manual.

Applicability

The manual applies to the ACS880-31 drives.

Target audience

The reader is expected to know the fundamentals of electricity, wiring, electrical components and electrical schematic symbols.

The manual is written for readers worldwide. Both SI and imperial units are shown. Special US instructions for installations in the United States are given.

Purpose of the manual

This manual provides information needed for planning the installation, installing, and servicing the drive.

Categorization by frame (size)

The drive is manufactured in frames. Some instructions and other information which only concern certain frames are marked with the symbol of the frame, for example R3. The frame is marked on the type designation label attached to the drive, see section [Type designation label](#) on page 35.

Quick installation and commissioning flowchart

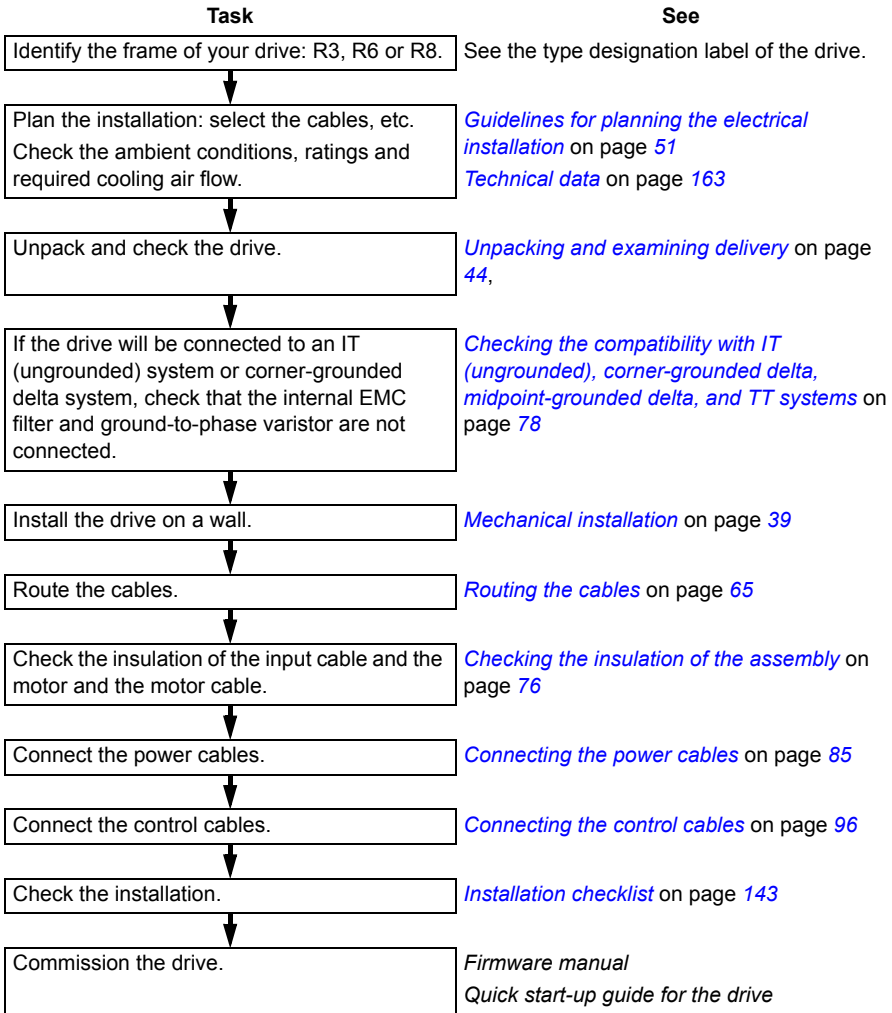

Terms and abbreviations

Term/abbreviation	Explanation
ACX-AP-x	Assistant control panel, advanced operator keypad for communication with the drive.

Term/abbreviation	Explanation
Brake chopper	An external brake chopper conducts the surplus energy from the intermediate circuit of the drive to the brake resistor when necessary. The chopper operates when the DC link voltage exceeds a certain maximum limit. The voltage rise is typically caused by deceleration (braking) of a high inertia motor.
Brake resistor	Dissipates the drive surplus braking energy conducted by the brake chopper to heat. Essential part of the brake circuit. See Brake chopper .
Control board	Circuit board in which the control program runs.
Capacitor bank	See DC link capacitors .
DC link	DC circuit between rectifier and inverter
DC link capacitors	Energy storage which stabilizes the intermediate circuit DC voltage
DPMP-01	Control panel mounting platform (flush)
DPMP-02	Control panel mounting platform (surface)
Drive	Frequency converter for controlling AC motors
EMC	Electromagnetic compatibility
EFB	Embedded fieldbus
FAIO-01	Optional analog I/O extension module
FCAN-01	Optional CANopen adapter module
FCNA-01	ControlNet adapter module
FDIO-01	Optional digital I/O extension module
FECA-01	Optional EtherCAT adapter module
FENA-21	Optional Ethernet adapter module for EtherNet/IP, Modbus TCP and PROFINET IO protocols
FEPL-02	Optional Ethernet POWERLINK adapter module
FIO-01	Optional digital I/O extension module
FIO-11	Optional analog I/O extension module
FPBA-01	Optional PROFIBUS DP adapter module
FSO-12	Optional functional safety module
FSO-21	Optional functional safety module
Frame (size)	Refers to drive physical size, for example R3. The type designation label attached to the drive shows the frame of the drive, see section Type designation key on page 36.
I/O	Input/Output
IGBT	Insulated gate bipolar transistor
Intermediate circuit	See DC link .
Inverter	Converts direct current and voltage to alternating current and voltage.
NETA-21	Remote monitoring tool

Term/abbreviation	Explanation
Network control	With fieldbus protocols based on the Common Industrial Protocol (CIP™), such as DeviceNet and Ethernet/IP, denotes the control of the drive using the Net Ctrl and Net Ref objects of the ODVAAC/DC Drive Profile. For more information, see www.odva.org , and the following manuals: <ul style="list-style-type: none"> • <i>FDNA-01 DeviceNet adapter module user's manual</i> (3AFE68573360 [English]), and • <i>FENA-01/-11/-21 Ethernet adapter module user's manual</i> (3AUA0000093568 [English]).
Parameter	User-adjustable operation instruction to the drive, or signal measured or calculated by the drive
PLC	Programmable logic controller
PROFIBUS, PROFIBUS DP, PROFINET IO	Registered trademarks of PI - PROFIBUS & PROFINET International
PTC	Positive temperature coefficient (PTC) refers to materials that experience an increase in electrical resistance when their temperature is raised.
R3, R6, R8	Frame (size)
Rectifier	Converts alternating current and voltage to direct current and voltage.
STO	Safe torque off. See chapter The Safe torque off function on page 213.

Related documents

Drive manuals and guides	Code (English)
<i>ACS880 primary control program firmware manual</i>	3AUA0000085967
<i>Quick start-up guide for ACS880 drives with primary control program</i>	3AUA0000098062
<i>ACS880-31 hardware manual</i>	3AXD50000045933
<i>ACS880-31 quick installation guide</i>	3AXD50000048171
<i>ACX-AP-x assistant control panels user's manual</i>	3AUA0000085685
Option manuals and guides	
<i>ACS880 drive module frames R1 to R9 for cabinet installation (options +P940 and +P944) supplement</i>	3AUA0000145446
<i>Flange mounting kit installation supplement</i>	3AXD50000019100
<i>Flange mounting kit quick installation guide for ACS880-11, ACS880-31, ACH580-31 and ACQ580-31 frame R3</i>	3AXD50000181506
<i>Flange mounting kit quick installation guide for ACS880-11, ACS880-31, ACH580-31 and ACQ580-31 frames R6 and R8</i>	3AXD50000133611
<i>Common mode filter kit for frames R7 and R8 (option +E208) installation guide</i>	3XD50000015179
<i>UK gland plate (+H358) installation guide for ACS880-11, ACS880-31, ACH580-31 and ACQ580-31</i>	3AXD50000110711
<i>ACS880 ATEX-certified Safe disconnection function application guide</i>	3AUA0000132231
<i>FCAN-01 CANopen adapter module user's manual</i>	3AFE68615500

<i>FCNA-01 ControlNet adapter module user's manual</i>	3AJA0000141650
<i>FDNA-01 DeviceNet™ adapter module user's manual</i>	3AFE68573360
<i>FECA-01 EtherCAT adapter module user's manual</i>	3AJA0000068940
<i>FENA-01/-11/-21 Ethernet adapter module user's manual</i>	3AJA0000093568
<i>FEPL-02 Ethernet POWERLINK adapter module user's manual</i>	3AJA0000123527
<i>FPBA-01 PROFIBUS DP adapter module user's manual</i>	3AFE68573271
<i>FPTC-01 thermistor protection module (option +L536) for ACS880 drives user's manual</i>	3AXD50000027750
<i>FPTC-02 ATEX-certified thermistor relay module, Ex II (2) GD (+L537+Q971) for ACS880 drives user's manual</i>	3AXD50000027782
<i>FSCA-01 RS-485 adapter module user's manual</i>	3AJA0000109533
<i>FSO-12 safety functions module user's manual</i>	3AXD50000015612
<i>FSO-21 safety functions module user's manual</i>	3AXD50000015614

Tool and maintenance manuals and guides

<i>Drive composer PC tool user's manual</i>	3AJA0000094606
<i>Converter module capacitor reforming instructions</i>	3BFE64059629
<i>NETA-21 remote monitoring tool user's manual</i>	3AJA0000096939
<i>NETA-21 remote monitoring tool installation and start-up guide</i>	3AJA0000096881



Operation principle and hardware description

Contents of this chapter

This chapter briefly describes the operation principle, layout, type designation label and type designation information. It also shows a general diagram of power connections and control interfaces.

Operation principle

The ACS880-31 is a ultra-low harmonic drive for controlling asynchronous AC induction motors, AC induction servomotors, permanent magnet motors and synchronous reluctance motors.

The drive includes a line-side converter and a motor-side converter. The parameters and signals for both converters are combined into one primary user program.

The figure below shows the simplified main circuit diagram of the drive.

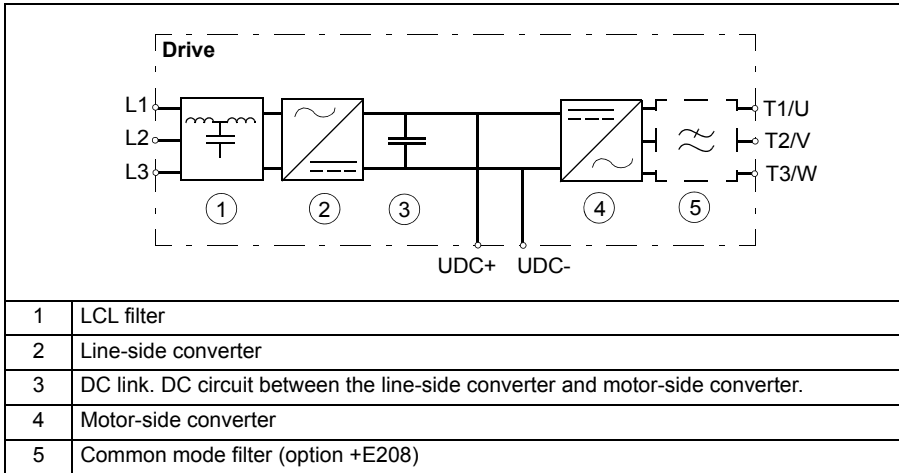

The line-side converter rectifies three phase AC current to direct current for the intermediate DC link of the drive. The intermediate DC link further supplies the motor-side converter that runs the motor.

Both converters consist of six insulated gate bipolar transistors (IGBT) with free wheeling diodes. The content of AC voltage and current harmonics is low. The LCL filter suppresses the harmonics further.

The line-side and motor-side converters have their own control programs. The parameters of both programs can be viewed and changed using a control panel.

DC connection

You can connect an external brake chopper to the drive via the DC terminals. See chapter [Resistor braking](#) on page 225.



WARNING! Do not connect the drive DC link to a common DC system. The drive will get damaged.

Layout

The layout of the drive is shown below.

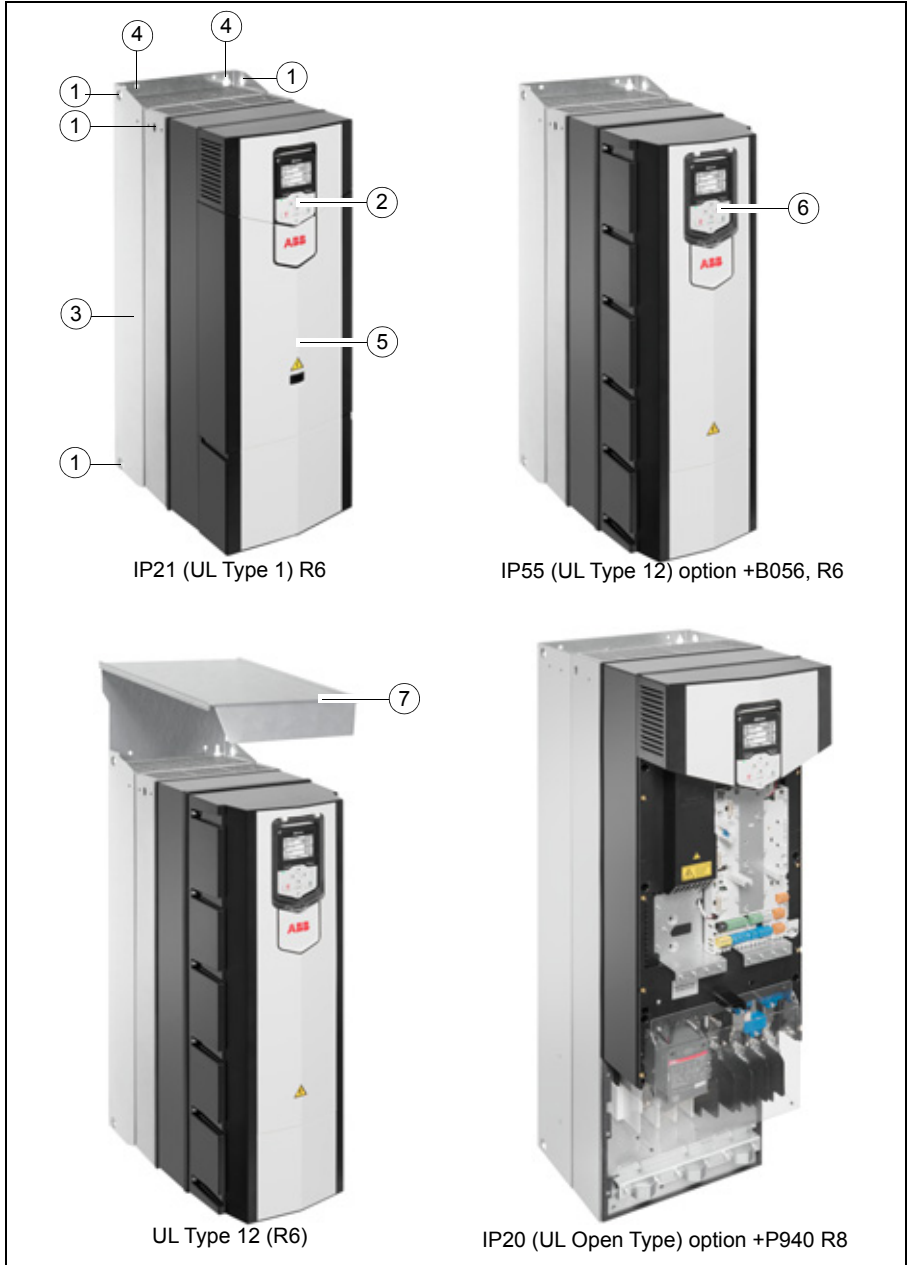

30 Operation principle and hardware description

1	Lifting holes (2 pcs in frame R3, 6 pcs in frames R6 and R8)	5	Front cover
2	Control panel	6	Control panel behind the control panel cover
3	Heatsink	7	Hood in frames R6 and R8.
4	Mounting points (4 pieces)	-	-

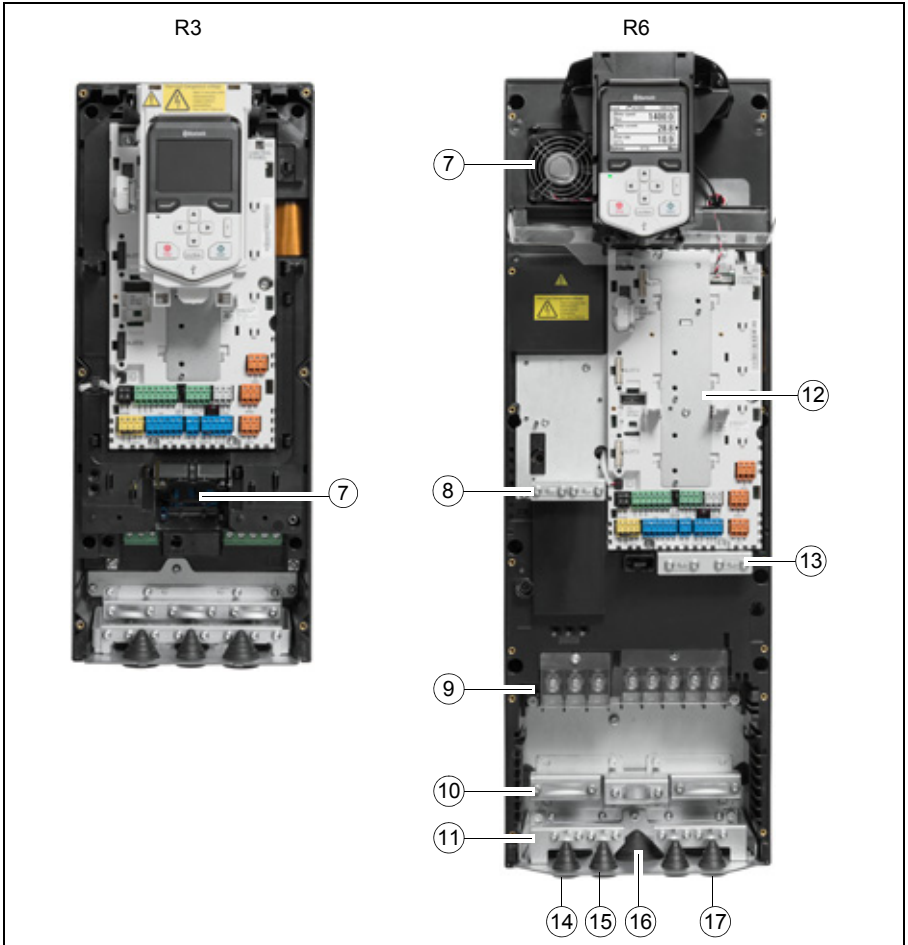

7	Auxiliary cooling fan. For frame R3 in IP55 (UL Type 12 drives) only.	13	Clamps for securing the control cables mechanically
8	Clamps for securing the FSO wiring mechanically	14	Input power cable entry behind the 360-degree grounding clamps
9	Power cable connection terminals behind the shroud	15	Control cable entry (4pcs)
10	360-degree grounding clamps for power cable shields	16	DC cable entry
11	360-degree grounding clamps for control cable shields	17	Motor cable entry behind the 360-degree grounding clamps
12	Control unit with I/O cable connection terminals	-	-

The main cooling fan is at the top of the drive in frame R3 and at the bottom in frames R6 and R8.

The layout of external control connection terminals of the drive is shown below.

XPOW	External power input
XAI	Analog inputs
XAO	Analog outputs
XD2D	Drive-to-drive link
XRO1	Relay output 1
XRO2	Relay output 2
XRO3	Relay output 3
XD24	Start interlock connection (DIIL) and +24 V output
XDIO	Digital input/outputs
XDI	Digital inputs
XSTO	Safe torque off connection
X12	Connector for safety functions modules (optional)
X13	Control panel connection
X202	Option slot 1
X203	Option slot 2
X204	Option slot 3
X205	Memory unit connection
X208	Auxiliary cooling fan connection
J1, J2	Voltage/Current selection jumpers (J1, J2) for analog inputs
J3, J6	Drive-to-drive link termination jumper (J3), common digital input ground selection jumper (J6)

Overview of power and control connections

The logical diagram below shows the power connections and control interfaces of the drive.

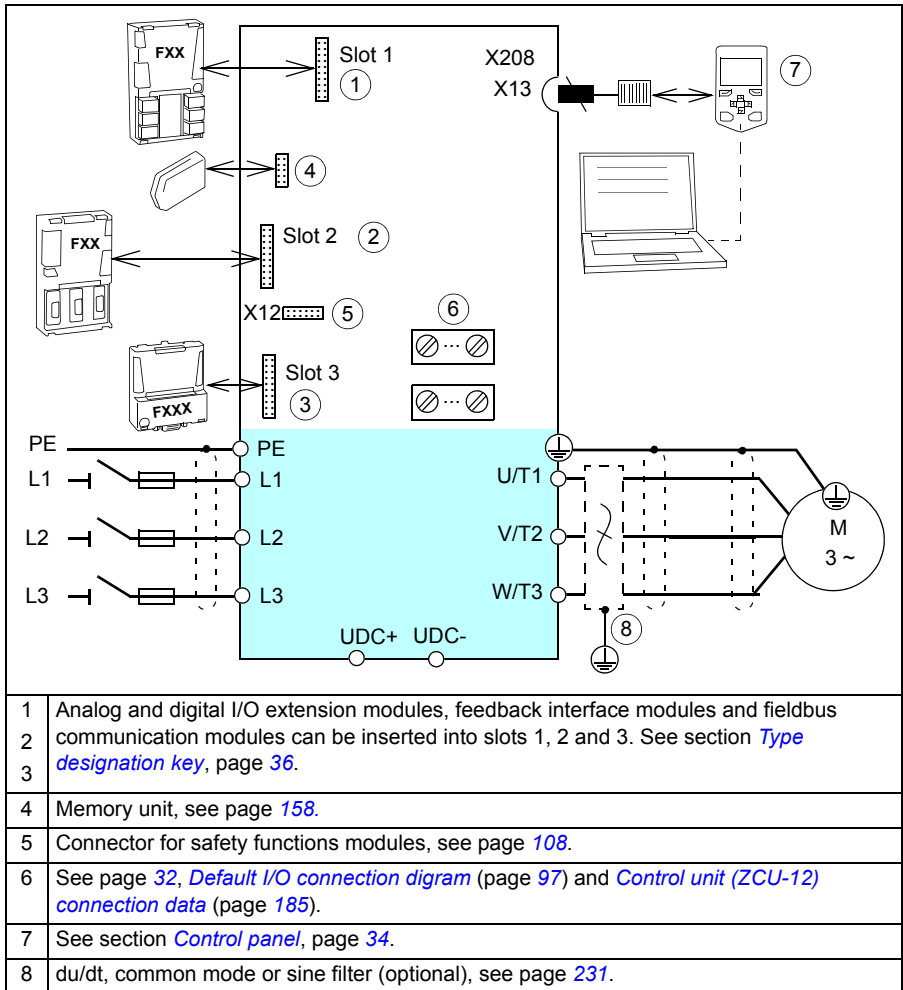

Control panel

To remove the control panel, press the retaining clip at the top (1a) and pull the panel forward from the top edge (1b).

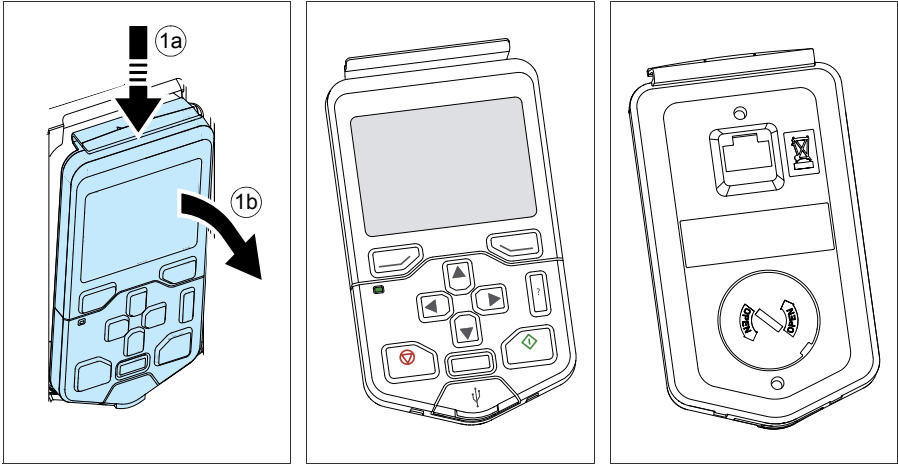

To reinstall the control panel, put the bottom of the container in position (1a), press the retaining clip at the top (1b) and push the control panel in at the top edge (1c).

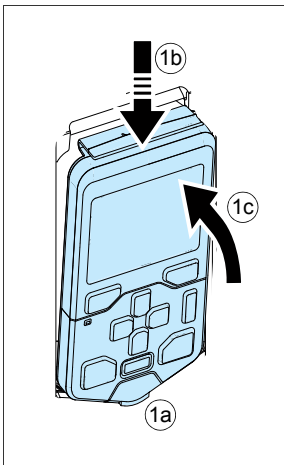

For the use of the control panel, see the firmware manual and *ACX-AP-x assistant control panels user's manual* (3AUA0000085685 [English]).

Type designation label

The type designation label includes IEC and UL (NEC) ratings, appropriate markings and the type designation and serial number, which allow identification of each drive. The type designation label is located on the left side of the drive. An example label is shown below.

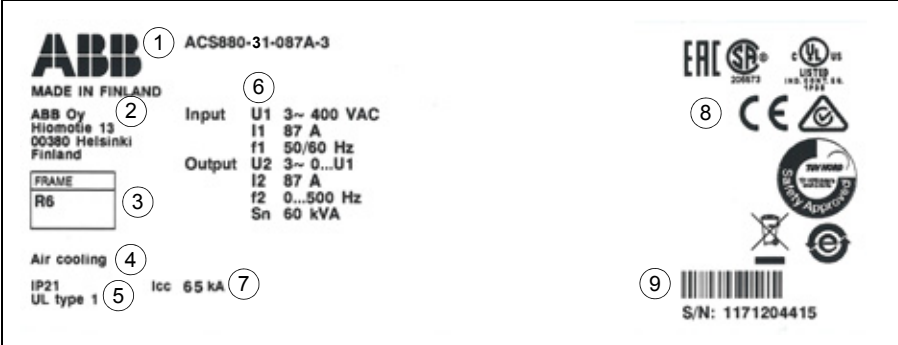
	
1	Type designation, see section Type designation key on page 36.
2	Name and address of the manufacturer
3	Frame (size)
4	Type of the drive, for example, with Air cooling
5	Degree of protection
6	Nominal ratings in the supply voltage range, see section Ratings on page 163, section Electrical power network specification on page 183 and section Motor connection data on page 184.
7	Rated conditional short-circuit current, see section Electrical power network specification on page 183.
8	Valid markings
9	S/N: Serial number of format MYYWWXXXX, where M: Manufacturer YY: 16, 17, 18, ... for 2016, 2017, 2018, ... WW: 01, 02, 03, ... for week 1, week 2, week 3, ... XXXXX: Integer starting every week from 0001

CODE	DESCRIPTION
Control panel	
0J400	No control panel. Includes integrated panel holder cover. With + P940 panel holder cover is not included..
J424	Blank control panel cover (no control panel)
J425	ACS-AP-I Assistant control panel
I/O (one slot available for I/O options)	
L500	FIO-11 analog I/O extension module
L501	FIO-01 digital I/O extension module
L502	FEN-31 HTL incremental encoder interface module
L503	FDCCO-01 optical DDCS communication adapter module
L508	FDCCO-02 optical DDCS communication adapter module
L516	FEN-21 resolver interface module
L517	FEN-01 TTL incremental encoder interface module
L525	FAIO-01 analog I/O extension module
L536	FPTC-01 thermistor protection module
L537	FPTC-02 ATEX certified thermistor protection module. Requires option Q971.
Safety	
Q971	ATEX certified safe disconnection function, EX II (2) GD. Sold only with option L357.
Q972	Safety functions module FSO-21 Not with Q973.
Q973	Safety functions module FSO-12 Not with Q972.
Q982	FSPS-21 safety functions fieldbus module. PROFIsafe safety communication.
Fieldbus adapters	
K451	FDNA-01 DeviceNet™
K454	FPBA-01 PROFIBUS DP
K457	FCAN-01 CANopen
K458	FSCA-01 RS-485 adapter module
K462	FCNA-01 ControlNet™ adapter module
K469	FECA-01 EtherCAT
K470	FEPL-02 Ethernet POWERLINK
K473	FENA-11 Ethernet (EtherNet/IP™, Modbus/TCP, PROFINET)
K475	FENA-21 2-port Ethernet (EtherNet/IP™, Modbus/TCP, PROFINET)
K487	FENA-11 with preloaded EtherNet/IP
K488	FENA-11 with preloaded Modbus/TCP
K489	FENA-11 with preloaded PROFINET
K490	FENA-21 with preloaded EtherNet/IP
K491	FENA-21 with preloaded Modbus/TCP

CODE	DESCRIPTION
K492	FENA-21 with preloaded PROFINET
Full set of printed manuals in selected language. Note: The delivered manual set may include manuals in English if the translation is not available.	
R700	English
R701	German
R702	Italian
R703	Dutch
R704	Danish
R705	Swedish
R706	Finnish
R707	French
R708	Spanish
R709	Portuguese (Portugal)
R711	Russian
R712	Chinese
R714	Turkish
Specialities	
P904	Extended warranty
P940	Drive without front covers and bottom plate. Includes panel holder and cable between panel holder and control unit. IP20 (UL type 0)
P931	Extended warranty 36 months
P932	Extended warranty 60 months

3AXD10000382217

4

Mechanical installation

Contents of this chapter

The chapter tells how to check the installation site, unpack, check the delivery and install the drive mechanically.

For mechanical installation of flange mounted drives (options +P940 and P944), see

Safety



WARNING! Frame R6 and R8: Lift the drive with a lifting device. Use the lifting eyes of the drive. Do not tilt the drive. **The drive is heavy and its center of gravity is high. An overturning drive can cause physical injury.**

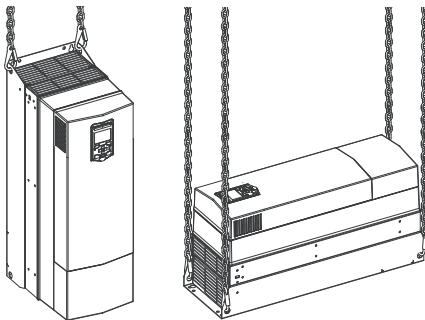

Examining the installation site

The drive must be installed on the wall. There are three alternative ways to install it:

- vertically alone. Do not install the drive upside down
- vertically side by side
- horizontally alone, IP21 (UL Type 1) only.

Note 1: The vibration specification in section [Ambient conditions](#) on page [192](#) may not be fulfilled.

Note 2: IP21 (UL Type 1) construction only meets IP20 (UL Type Open) in horizontal orientation.



Free space requirements are shown in the drawings below.

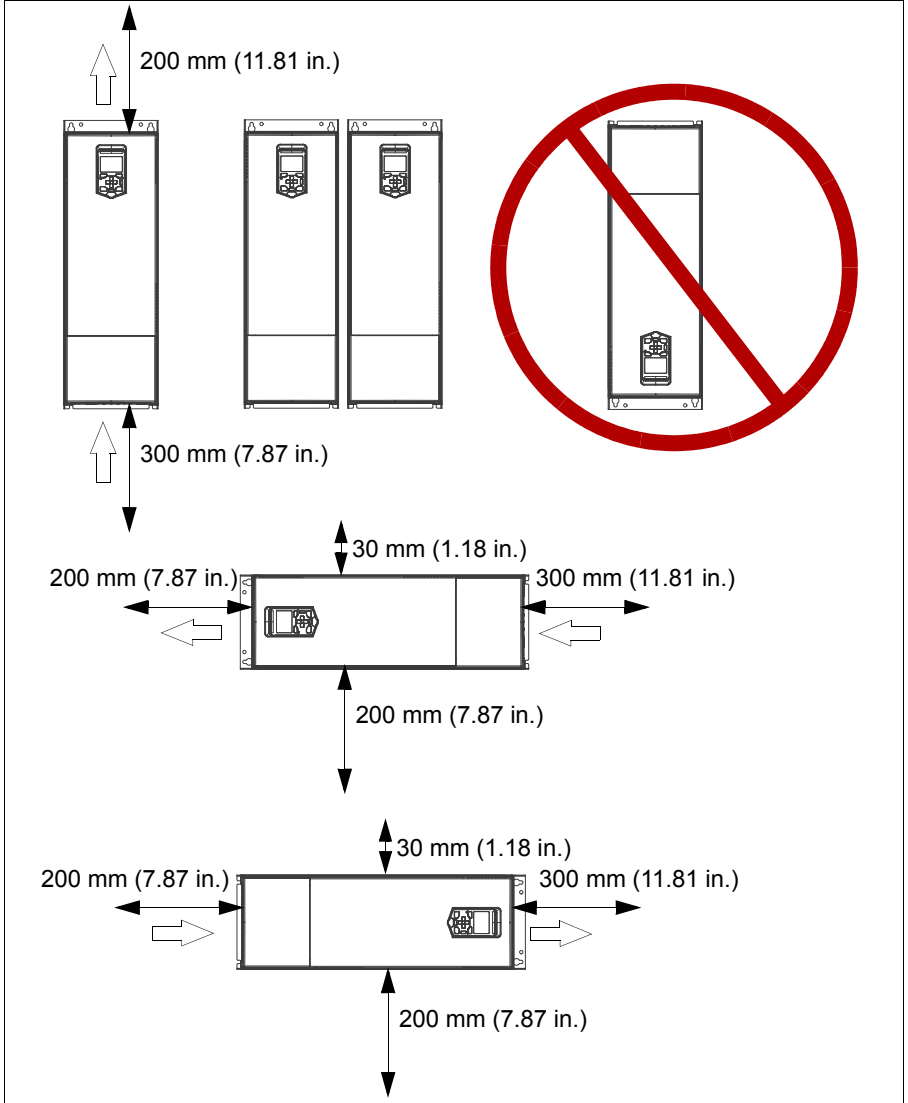

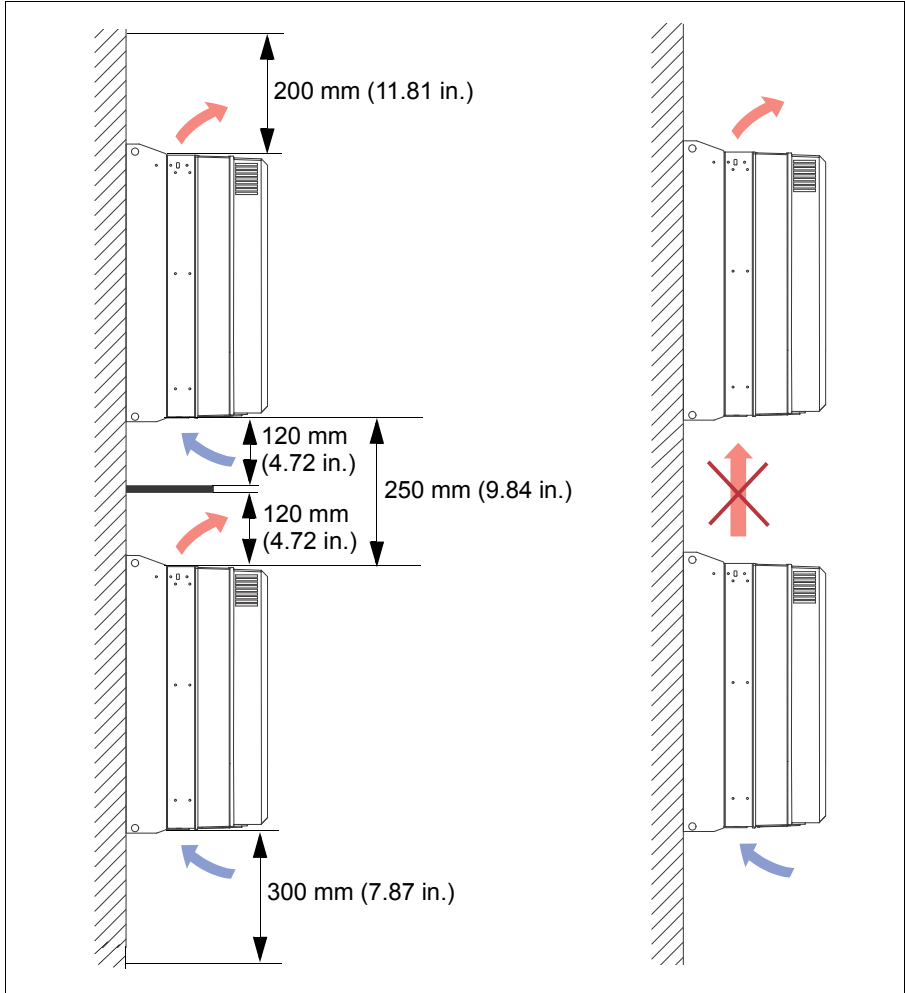

Check the installation site:

- The installation site is sufficiently ventilated or cooled to remove heat from the drive. See section [Losses, cooling data and noise](#) on page 180.
- The operation conditions of the drive meet the specifications given in section [Ambient conditions](#) on page 192.
- The wall is as close to vertical as possible, of non-flammable material and strong enough to carry the weight of the drive.
- The floor/material below the installation is non-flammable.
- There is enough free space above and below the drive to enable cooling air flow, service and maintenance. See the required free space tables for each of the different mounting alignments on page 40.

Required tools

To install the drive mechanically, you need the following tools:

- drill with suitable bits
- screwdriver and/or wrench with a set of suitable bits (as appropriate for the installation hardware used)
- tape measure, if you will not be using the provided mounting template.

Moving the drive

Move the drive in its transport package to the installation site. Use a pallet truck when you move a heavy drive package.



Unpacking and examining delivery

The figure below shows the drive package with its contents. Examine that all items are present and there are no signs of damage. Read the data on the type designation label of the drive to make sure that the drive is of the correct type. See section [Type designation label](#) on page 35.

R3 IP21 (UL Type 1) and IP55 (UL Type 12)

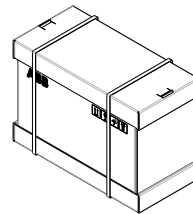
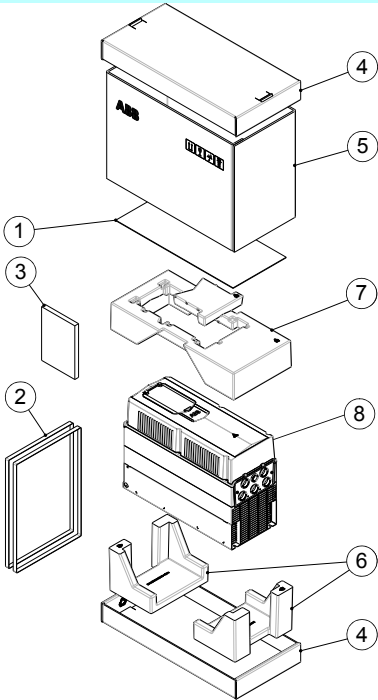

3AXD5000041449

1	Mounting template	5	Sleeve
2	PET straps	6	Package cushion
3	Printed quick guides and manuals, multilingual residual voltage warning sticker, manuals CD	7	Foam cushion
4	Tray	8	Drive with factory installed options.

To unpack:

- Cut the straps (1).
- Remove the tray (3) and sleeve (4).
- Remove the cover protecting film.
- Lift the drive.

R6 IP21 (UL Type 1)

3AXD50000038252

1	Printed quick guides and manuals, multilingual residual voltage warning sticker, Manuals CD	6	Plastic bag
2	Accessories	7	Cardboard sleeve
3	VCI bag	8	Outer box
4	Mounting template	9	Pallet
5	PET straps	10	Drive with factory installed options

To unpack:

- Cut the straps (5).
- Remove the outer box (4) and cardboard sleeve (7).
- Open the VCI bag (3).
- Undo the attaching screws (a, b).
- Lift the drive.



R6 IP55 (UL Type 12)

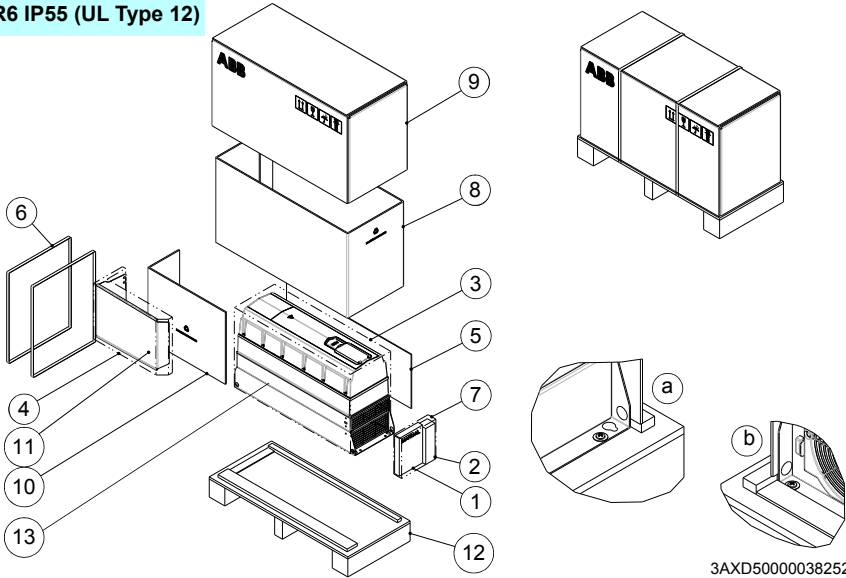

3AXD5000038252



1	Printed quick guides and manuals, multilingual residual voltage warning sticker, Manuals CD	8	Cardboard sleeve
2	Accessories	9	Outer box
3	VCI bag	10	Cardboard insert
4	Bubble wrap	11	UL Type 12 hood
5	Mounting template	12	Pallet
6	PET straps	13	Drive with factory installed options.
7	Plastic bag	-	-

To unpack:

- Cut the straps (6).
- Remove the outer box (9) and cardboard sleeve (8).
- Remove the VCI bag (3).
- Undo the attaching screws (a, b).
- Lift the drive.

R8 IP21 (UL Type 1)

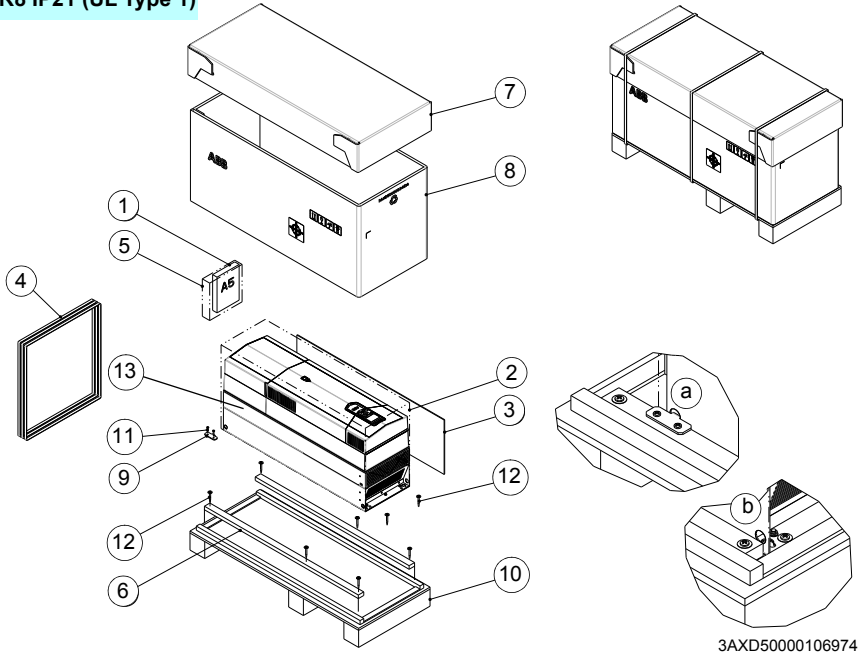

1	Printed quick guides and manuals, multilingual residual voltage warning sticker, Manuals CD	7	Tray
2	VCI bag	8	Cardboard sleeve
3	Mounting template	9	Plywood support
4	PET straps	10	Pallet
5	Plastic bag	11, 12	Screw
6	Packing bracket	13	Drive with factory installed options

To unpack:

- Cut the straps (4).
- Remove the tray (7) and cardboard sleeve (8).
- Open the VCI bag (2).
- Undo the attaching screws (a, b).
- Lift the drive.



R8 IP55 (UL Type 12)

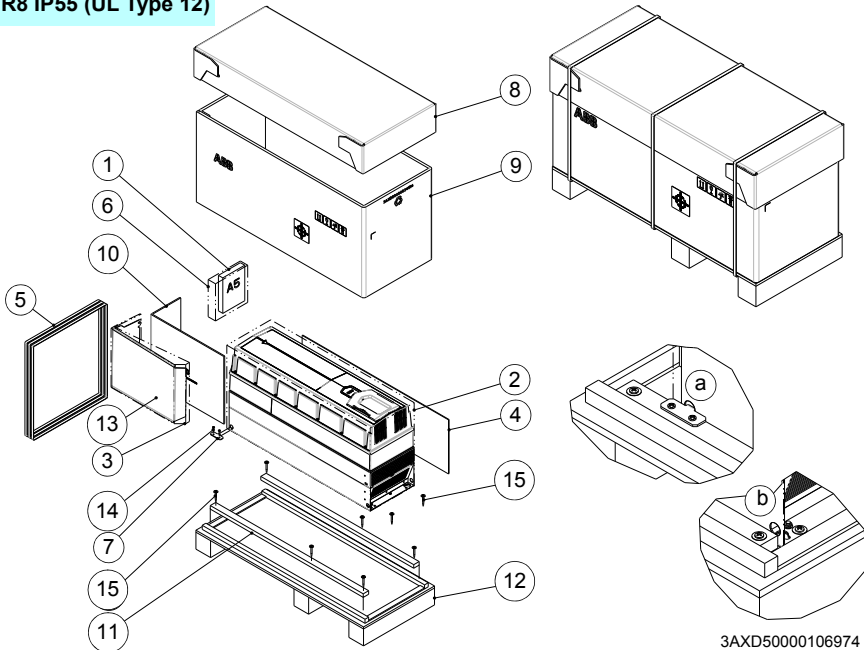

3AXD50000106974

1	Printed quick guides and manuals, multilingual residual voltage warning sticker, Manuals CD	8	Tray
2	VCI bag	9	Cardboard sleeve
3	Bubble wrap	10	Not included
4	Mounting template	11	Plywood support
5	PET straps	12	Pallet
6	Plastic bag	13	UL Type 12 hood
7	Packing bracket	14	Drive with factory installed options.

To unpack:

- Cut the straps (5).
- Remove the tray (8) and cardboard sleeve (9).
- Remove the VCI bag (2).
- Undo the attaching screws (a, b).
- Lift the drive.

Installing the drive

1. Mark the hole locations using the mounting template included in the package.
2. Drill the mounting holes.
3. Insert anchors or plugs into the holes and start the screws or bolts into the anchors or plugs. Drive the screws or bolts long enough into the wall to make them carry the weight of the drive.
4. Position the drive onto the bolts on the wall. For R6 and R8 with option +B056 (UL Type 12), see also step 6.
5. Tighten the bolts in the wall securely.

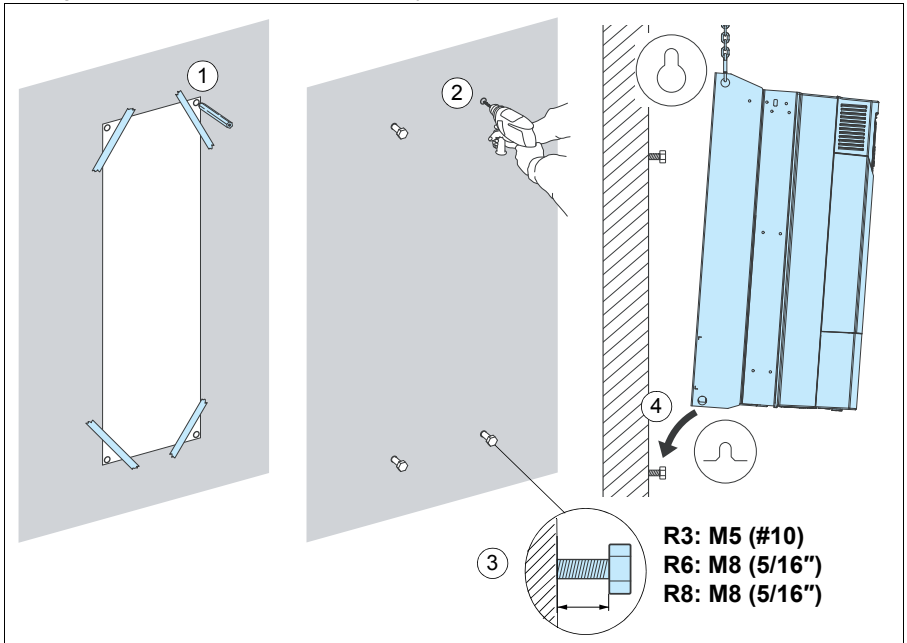

6. Frames R6 and R8 with option +B056 (UL Type 12) installation: Install the hood on top of the drive before you tighten the upper fastening bolts. Place the vertical

edge of the hood in between the wall and the drive back plate. Then, tighten the bolts to fasten the hood on its place.

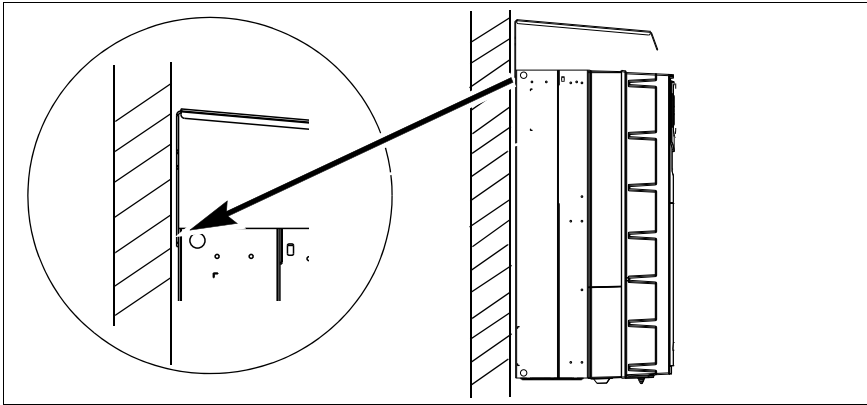

Flange mounting (option +C135)

Instructions for flange mounting are delivered with the flange mounting kit: See *Flange mounting kit quick installation guide for frame R3* (3AXD50000133208 [English]) or *Flange mounting kit quick installation guide for frames R6 and R8* (3AXD50000133611 [English]). For more information on flange mounting, see *Flange mounting kit installation supplement* (3AXD50000019100 [English]).

Cabinet installation (option +P940)

See ACS880 drive module frames R1 to R9 for cabinet installation (options +P940 and +P944) supplement (3AUA0000145446 [English]).



5

Guidelines for planning the electrical installation

Contents of this chapter

This chapter contains instructions for planning the electrical installation of the drive, for example, for checking the compatibility of the motor and drive, selecting cables, protections and cable routing.

Note: The installation must always be designed and made according to applicable local laws and regulations. The manufacturer does not assume any liability whatsoever for any installation which breaches the local laws and/or other regulations. Furthermore, if the recommendations given by the manufacturer are not followed, the drive may experience problems that the warranty does not cover.

Selecting the supply disconnecting device

Install a hand-operated input disconnecting device between the AC power source and the drive. The disconnecting device must be of a type that can be locked to the open position for installation and maintenance work.

■ European Union

To meet the European Union Directives, according to standard EN 60204-1, *Safety of Machinery*, the disconnecting device must be one of the following types:

- switch-disconnector of utilization category AC-23B (EN 60947-3)
 - disconnector that has an auxiliary contact that in all cases causes switching devices to break the load circuit before the opening of the main contacts of the disconnector (EN 60947-3)
 - circuit breaker suitable for isolation in accordance with EN 60947-2.
-

■ North American Market

The disconnecting device must conform to the applicable local safety regulations.

■ Other regions

The disconnecting device must conform to the applicable local safety regulations.

Checking the compatibility of the motor and drive

Use an asynchronous AC induction motor, permanent magnet synchronous motor, AC induction servomotor or synchronous reluctance motor with the drive. Several induction motors can be connected to the drive at a time but only one permanent magnet motor.

Check that the motor and the drive are compatible. See the section [Ratings](#) on page [163](#).

Ensure that the motor withstands the maximum peak voltage in the motor terminals. See the [Requirements table](#) on page [53](#). For basics of protecting the motor insulation and bearings in drive systems, refer to section [Protecting the motor insulation and bearings](#) on page [52](#).

Note:

- Consult the motor manufacturer before using a motor the nominal voltage of which differs from the AC line voltage connected to the drive input.
- The voltage peaks at the motor terminals are relative to the supply voltage of the drive, not the drive output voltage.
- If the motor and drive are not of the same size, consider the following operation limits of the drive control program:
 - motor nominal voltage range $1/6 \dots 2 \cdot U_N$
 - motor nominal current range $1/6 \dots 2 \cdot I_N$ of the drive in DTC control and $0 \dots 2 \cdot I_N$ in scalar control. The control mode is selected by a drive parameter.

■ Protecting the motor insulation and bearings

The drive employs modern IGBT inverter technology. Regardless of frequency, the drive output comprises pulses of approximately the drive DC bus voltage with a very short rise time. The pulse voltage can almost double at the motor terminals, depending on the attenuation and reflection properties of the motor cable and the terminals. This can cause additional stress on the motor and motor cable insulation.

Modern variable speed drives with their fast rising voltage pulses and high switching frequencies can generate current pulses that flow through the motor bearings. This can gradually erode the bearing races and rolling elements.

Optional du/dt filters protect motor insulation system and reduce bearing currents. Optional common mode filters mainly reduce bearing currents. Insulated N-end (non-drive end) bearings protect the motor bearings.

■ Requirements table

The following table shows how to select the motor insulation system and when an optional drive du/dt and common mode filters and insulated N-end (non-drive end) motor bearings are required. Ignoring the requirements or improper installation may shorten motor life or damage the motor bearings and voids the warranty.

Motor type	Nominal AC supply voltage	Requirement for		
		Motor insulation system	ABB du/dt and common mode filters, insulated N-end motor bearings	
			$P_N < 100$ kW and frame size < IEC 315	$100 \text{ kW} \leq P_N < 350$ kW or IEC 315 \leq frame size < IEC 400
		$P_N < 134$ hp and frame size < NEMA 500	$134 \text{ hp} \leq P_N < 469$ hp or NEMA 500 \leq frame size \leq NEMA 580	
ABB motors				
Random-wound M2_, M3_ and M4_	$U_N \leq 500$ V	Standard	-	+ N
	$500 \text{ V} < U_N \leq 600$ V	Standard	+ du/dt	+ du/dt + N
		or	Reinforced	-
	$600 \text{ V} < U_N \leq 690$ V (cable length ≤ 150 m)	Reinforced	+ du/dt	+ du/dt + N
	$600 \text{ V} < U_N \leq 690$ V (cable length > 150 m)	Reinforced	-	+ N
Form-wound HX_ and AM_	$380 \text{ V} < U_N \leq 690$ V	Standard	n.a.	+ N + CMF
Old* form-wound HX_ and modular	$380 \text{ V} < U_N \leq 690$ V	Check with the motor manufacturer.	+ du/dt with voltages over 500 V + N + CMF	
Random-wound HX_ and AM_ **	$0 \text{ V} < U_N \leq 500$ V	Enamelled wire with fiber glass taping	+ N + CMF	
	$500 \text{ V} < U_N \leq 690$ V		+ du/dt + N + CMF	

Motor type	Nominal AC supply voltage	Requirement for			
		Motor insulation system	ABB du/dt and common mode filters, insulated N-end motor bearings		
			$P_N < 100 \text{ kW}$ and frame size < IEC 315	$100 \text{ kW} \leq P_N < 350 \text{ kW}$ or IEC 315 \leq frame size < IEC 400	
		$P_N < 134 \text{ hp}$ and frame size < NEMA 500	$134 \text{ hp} \leq P_N < 469 \text{ hp}$ or NEMA 500 \leq frame size \leq NEMA 580		
HDP	Consult the motor manufacturer.				
Non-ABB motors					
Random-wound and form-wound	$U_N \leq 420 \text{ V}$	Standard: $\dot{U}_{LL} = 1300 \text{ V}$	-	+ N or CMF	
	$420 \text{ V} < U_N \leq 500 \text{ V}$	Standard: $\dot{U}_{LL} = 1300 \text{ V}$	+ du/dt	+ du/dt + (N or CMF)	
		or			
	$500 \text{ V} < U_N \leq 600 \text{ V}$	Reinforced: $\dot{U}_{LL} = 1600 \text{ V}$, 0.2 microsecond rise time	-	+ N or CMF	
		Reinforced: $\dot{U}_{LL} = 1600 \text{ V}$	+ du/dt	+ du/dt + (N or CMF)	
	$600 \text{ V} < U_N \leq 690 \text{ V}$	or			
		Reinforced: $\dot{U}_{LL} = 1800 \text{ V}$	-	+ N or CMF	
	$600 \text{ V} < U_N \leq 690 \text{ V}$	Reinforced: $\dot{U}_{LL} = 1800 \text{ V}$	+ du/dt	+ du/dt + N	
Reinforced: $\dot{U}_{LL} = 2000 \text{ V}$, 0.3 microsecond rise time ***		-	N + CMF		

* manufactured before 1.1.1998

** For motors manufactured before 1.1.1998, check for additional instructions with the motor manufacturer.

*** If the intermediate DC circuit voltage of the drive is increased from the nominal level by resistor braking, check with the motor manufacturer if additional output filters are needed in the applied drive operation range.

The abbreviations used in the table are defined below.

Abbr.	Definition
U_N	Nominal AC line voltage
\hat{U}_{LL}	Peak line-to-line voltage at motor terminals which the motor insulation must withstand
P_N	Motor nominal power
du/dt	du/dt filter at the output of the drive. Available from ABB as an optional add-on kit.
CMF	Common mode filter. Depending on the drive type, CMF is available from ABB as an optional add-on kit.
N	N-end bearing: insulated motor non-drive end bearing
n.a.	Motors of this power range are not available as standard units. Consult the motor manufacturer.

Additional requirements for explosion-safe (EX) motors

If you will use an explosion-safe (EX) motor, follow the rules in the requirements table above. In addition, consult the motor manufacturer for any further requirements.

Additional requirements for ABB motors of types other than M2_, M3_, M4_, HX_ and AM_

Use the selection criteria given for non-ABB motors.

Additional requirements for the braking applications

When the motor brakes the machinery, the intermediate circuit DC voltage of the drive increases, the effect being similar to increasing the motor supply voltage by up to 20 percent. Consider this voltage increase when specifying the motor insulation requirements if the motor will be braking a large part of its operation time.

Example: Motor insulation requirement for a 400 V AC line voltage application must be selected as if the drive were supplied with 480 V.

Additional requirements for ABB high-output and IP23 motors

The rated output power of high output motors is higher than what is stated for the particular frame size in EN 50347 (2001). This table shows the requirements for ABB random-wound motor series (for example, M3AA, M3AP and M3BP).

Nominal mains voltage (AC line voltage)	Requirement for			
	Motor insulation system	ABB du/dt and common mode filters, insulated N-end motor bearings		
		$P_N < 100 \text{ kW}$	$100 \text{ kW} \leq P_N < 200 \text{ kW}$	$P_N \geq 200 \text{ kW}$
		$P_N < 140 \text{ hp}$	$140 \text{ hp} \leq P_N < 268 \text{ hp}$	$P_N \geq 268 \text{ hp}$
$U_N \leq 500 \text{ V}$	Standard	-	+ N	+ N + CMF
$500 \text{ V} < U_N \leq 600 \text{ V}$	Standard	+ du/dt	+ du/dt + N	+ du/dt + N + CMF
	or			
	Reinforced	-	+ N	+ N + CMF
$600 \text{ V} < U_N \leq 690 \text{ V}$	Reinforced	+ du/dt	+ du/dt + N	+ du/dt + N + CMF

Additional requirements for non-ABB high-output and IP23 motors

The rated output power of high output motors is higher than what is stated for the particular frame size in EN 50347 (2001). The table below shows the requirements for random-wound and form-wound non-ABB motors.

Nominal AC line voltage	Requirement for		
	Motor insulation system	ABB du/dt filter, insulated N-end bearing and ABB common mode filter	
		$P_N < 100 \text{ kW}$ or frame size < IEC 315	$100 \text{ kW} \leq P_N < 350 \text{ kW}$ or IEC 315 \leq frame size < IEC 400
		$P_N < 134 \text{ hp}$ or frame size < NEMA 500	$134 \text{ hp} \leq P_N < 469 \text{ hp}$ or NEMA 500 \leq frame size \leq NEMA 580
$U_N \leq 420 \text{ V}$	Standard: $\hat{U}_{LL} = 1300 \text{ V}$	+ N or CMF	+ N + CMF

Nominal AC line voltage	Requirement for		
	Motor insulation system	ABB du/dt filter, insulated N-end bearing and ABB common mode filter	
		$P_N < 100 \text{ kW}$ or frame size $< \text{IEC 315}$	$100 \text{ kW} \leq P_N < 350 \text{ kW}$ or $\text{IEC 315} \leq \text{frame size} < \text{IEC 400}$
	$P_N < 134 \text{ hp}$ or frame size $< \text{NEMA 500}$	$134 \text{ hp} \leq P_N < 469 \text{ hp}$ or $\text{NEMA 500} \leq \text{frame size} \leq \text{NEMA 580}$	
$420 \text{ V} < U_N \leq 500 \text{ V}$	Standard: $\hat{U}_{LL} = 1300 \text{ V}$	+ du/dt + (N or CMF)	+ du/dt + N + CMF
	or		
	Reinforced: $\hat{U}_{LL} = 1600 \text{ V}$, 0.2 microsecond rise time	+ N or CMF	+ N + CMF
$500 \text{ V} < U_N \leq 600 \text{ V}$	Reinforced: $\hat{U}_{LL} = 1600 \text{ V}$	+ du/dt + (N or CMF)	+ du/dt + N + CMF
	or		
	Reinforced: $\hat{U}_{LL} = 1800 \text{ V}$	+ N or CMF	+ N + CMF
$600 \text{ V} < U_N \leq 690 \text{ V}$	Reinforced: $\hat{U}_{LL} = 1800 \text{ V}$	+ du/dt + N	+ du/dt + N + CMF
	Reinforced: $\hat{U}_{LL} = 2000 \text{ V}$, 0.3 microsecond rise time	N + CMF	N + CMF

Additional data for calculating the rise time and peak line-to-line voltage

If you need to calculate the actual peak voltage and voltage rise time considering the actual cable length, proceed as follows:

- Peak line-to-line voltage: Read the relative \hat{U}_{LL}/U_N value from the appropriate diagram below and multiply it by the nominal supply voltage (U_N).
- Voltage rise time: Read the relative values \hat{U}_{LL}/U_N and $(du/dt)/U_N$ from the appropriate diagram below. Multiply the values by the nominal supply voltage (U_N) and substitute into equation $t = 0.8 \cdot \hat{U}_{LL}/(du/dt)$.

A

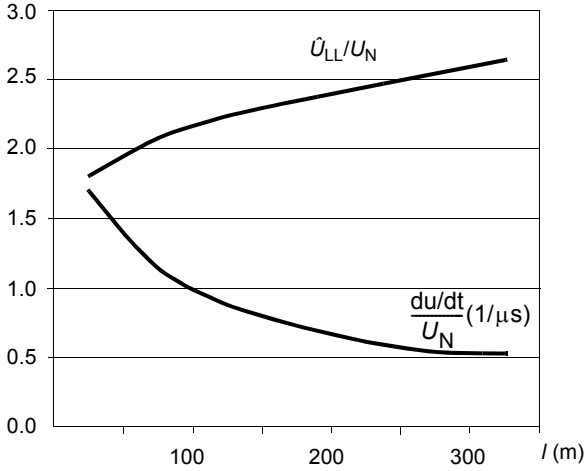

B

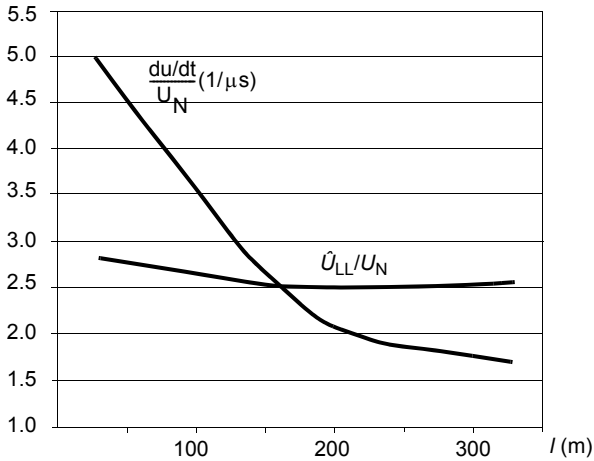

A	Drive with du/dt filter
B	Drive without du/dt filter
l	Motor cable length
\hat{U}_{LL}/U_N	Relative peak line-to-line voltage
$(du/dt)/U_N$	Relative du/dt value
Note: \hat{U}_{LL} and du/dt values are approximately 20% higher with resistor braking.	

Additional note for sine filters

Sine filters protect the motor insulation system. Therefore, du/dt filter can be replaced with a sine filter. The peak phase-to-phase voltage with the sine filter is approximately $1.5 \cdot U_N$.

Selecting the power cables

■ General rules

Select the input power and motor cables **according to local regulations**:

- The input power and the motor cables must be able to carry the corresponding load currents. See section [Ratings](#) (page 163) for the rated currents.
- The cable must be rated for at least 70 °C (90 °C for IP55 [UL Type 12]) maximum permissible temperature of conductor in continuous use. For US, see [Additional US requirements](#), page 63.
- The conductivity of the PE conductor must be sufficient, see the table on page 60.
- 600 V AC cable is accepted for up to 500 V AC.

To comply with the EMC requirements of the CE mark, use one of the approved cable types in section [Recommended power cable types](#) on page 61.

Symmetrical shielded cable reduces electromagnetic emission of the whole drive system as well as the stress on motor insulation, bearing currents and wear.

The protective conductor must always have an adequate conductivity. Unless local wiring regulations state otherwise, the cross-sectional area of the protective conductor must agree with the conditions that require automatic disconnection of the supply required in 411.3.2. of IEC 60364-4-41:2005 and be capable of withstanding the prospective fault current during the disconnection time of the protective device. The cross-sectional area of the protective conductor can either be selected from the table below or calculated according to 543.1 of IEC 60364-5-54. This table shows the minimum cross-sectional area related to the phase conductor size according to IEC 61800-5-1 when the phase conductor and the protective conductor are made of the same metal. If this is not so, the cross-sectional area of the protective earthing

conductor shall be determined in a manner which produces a conductance equivalent to that which results from the application of this table.

Cross-sectional area of the phase conductors S (mm ²)	Minimum cross-sectional area of the corresponding protective conductor S_p (mm ²)
$S \leq 16$	S
$16 < S \leq 35$	16
$35 < S$	$S/2$

■ Typical power cable sizes

The table below gives copper cable types with concentric copper shield for the drives with nominal current.

Type ACS880 -31-	Frame size	IEC ¹⁾		UL ⁴⁾	
		Cu cable type	Al cable type ²⁾	Cu cable type	Al cable type ³⁾
		mm ²	mm ²	AWG/kcmil	AWG/kcmil
		IEC ¹⁾		US ⁴⁾	
3-phase $U_N = 400$ V (380...415 V)					
09A4-3	R3	3×1.5	-	14	-
12A6-3	R3	3×1.5	-	14	-
017A-3	R3	3×6	-	10	-
025A-3	R3	3×6	-	10	-
032A-3	R6	3×10	3x16	8	-
038A-3	R6	3×10	3x16	8	-
045A-3	R6	3×16	3x35	6	-
061A-3	R6	3×25	3x35	4	-
072A-3	R6	3×35	3x50	2	-
087A-3	R6	3×50	3x70	2/0	-
105A-3	R8	3×50	70	1	-
145A-3	R8	3×95	120	2/0	-
169A-3	R8	3×120	150	3/0	-
206A-3	R8	3×150	-	250MCM	-
3-phase $U_N = 500$ V (380...500 V)					
07A6-5	R3	3×1.5	-	14	-
11A0-5	R3	3×1.5	-	14	-
014A-5	R3	3×6	-	10	-
021A-5	R3	3×6	-	10	-
027A-5	R6	3×10	3x16	8	-
034A-5	R6	3×10	3x16	8	-
040A-5	R6	3×16	3x35	6	-
052A-5	R6	3×25	3x35	4	-
065A-5	R6	3×35	3x50	2	-
077A-5	R6	3×35	3x70	2	-
101A-5	R8	3×50	70	1	-
124A-5	R8	3×95	95	2/0	-

Type ACS880 -31-	Frame size	IEC ¹⁾		UL ⁴⁾	
		Cu cable type	Al cable type ²⁾	Cu cable type	Al cable type ³⁾
		mm ²	mm ²	AWG/kcmil	AWG/kcmil
		IEC ¹⁾		US ⁴⁾	
156A-5	R8	3×120	150	3/0	-
180A-5	R8	3×150	-	250MCM	-

3AXD00000588487

- 1) The cable sizing is based on max. 9 cables laid on a cable ladder side by side, ambient temperature 30 °C, PVC insulation, surface temperature 70 °C (EN 60204-1 and IEC 60364-5-52/2001). For other conditions, size the cables according to local safety regulations, appropriate input voltage and the load current of the drive. See also page 181 for the accepted cable sizes of the drive.
- 2) Aluminum cables must not be used with drives of frame size R3.
- 3) In the USA, aluminum cables must not be used.
- 4) The cable sizing is based on NEC Table 310-16 for copper wires, 75 °C (167 °F) wire insulation at 40 °C (104 °F) ambient temperature. Not more than three current-carrying conductors in raceway or cable or earth (directly buried). For other conditions, size the cables according to local safety regulations, appropriate input voltage and the load current of the drive. See also page 181 for the accepted cable sizes of the drive.

Note: For ambient temperatures above +40 °C (+104 °F), the power cables must be rated for 90 °C (194 °F) minimum.

See also section [Terminal and entry data for the power cables](#) on page 181.

Alternative power cable types

The recommended and the not allowed power cable types to be used with the drive are presented below.

Recommended power cable types

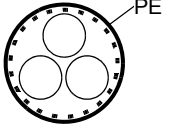
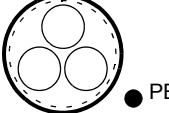
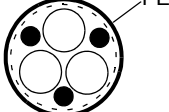
	<p>Symmetrical shielded cable with three phase conductors and a concentric PE conductor as the shield. The shield must meet the requirements of IEC 61800-5-1, see page 59. Check with local/state/country electrical codes for allowance.</p>
	<p>Symmetrical shielded cable with three phase conductors and a concentric PE conductor as the shield. A separate PE conductor is required if the shield does not meet the requirements of IEC 61800-5-1, see page 59.</p>
	<p>Symmetrical shielded cable with three phase conductors and symmetrically constructed PE conductor, and a shield. The PE conductor must meet the requirements of IEC 61800-5-1, see page 59.</p>

Power cable types for limited use

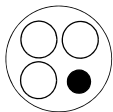
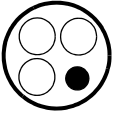
	<p>A four-conductor system (three phase conductors and a protective conductor on a cable tray) is not allowed for motor cabling (it is allowed for input cabling).</p> <p>⚠ WARNING! Do not use unshielded single core cables for drives on IT (ungrounded) networks. A dangerous voltage can become present on the nonconductive outer sheath of the cable. This can cause injury or death.</p>
	<p>A four-conductor system (three phase conductors and a PE conductor in a PVC conduit) is allowed for input cabling with phase conductor cross-section less than 10 mm² (8 AWG) or motors ≤ 30 kW (40 hp). Not allowed in the USA.</p>
	<p>Corrugated or EMT cable with three phase conductors and a protective conductor is allowed for motor cabling with phase conductor cross section less than 10 mm² (8 AWG) or motors ≤ 30 kW (40 hp).</p>

Not allowed power cable types

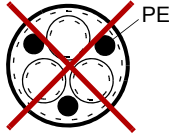
	<p>Symmetrical shielded cable with individual shields for each phase conductor is not allowed on any cable size for input or motor cabling.</p>
--	---

Motor cable shield

If the motor cable shield is used as the sole protective earth conductor of the motor, make sure that the conductivity of the shield is sufficient. See section [General rules](#) on page 59, or IEC 61800-5-1.

To effectively suppress radiated and conducted radio-frequency emissions, the cable shield conductivity must be at least 1/10 of the phase conductor conductivity. The requirements are easily met with a copper or aluminum shield. The minimum requirement of the motor cable shield of the drive is shown below. It consists of a concentric layer of copper wires with an open helix of copper tape or copper wire. The better and tighter the shield, the lower the emission level and bearing currents.

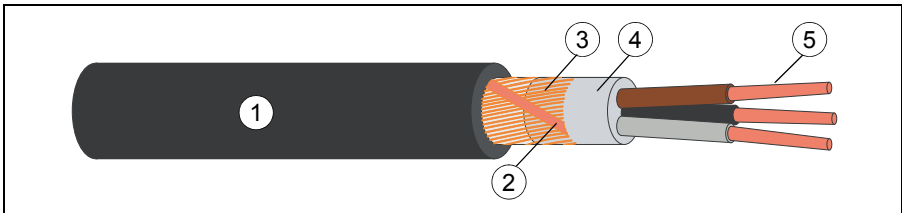

1	Sheath
2	Copper wire shield
3	Helix of copper tape or copper wire
4	Filling
5	Cable conductors

■ Additional US requirements

Use type MC continuous corrugated aluminum armor cable with symmetrical grounds or shielded power cable for the motor cables if metallic conduit is not used. For the North American market, 600 V AC cable is accepted for up to 500 V AC. 1000 V AC cable is required above 500 V AC (below 600 V AC). For drives rated over 100 amperes, the power cables must be rated for 75 °C (167 °F) or higher. For UL Type 12 drives of frame R6, the power cables must be rated for 90 °C (194 °F) minimum.

Conduit

Couple separate parts of a conduit together: bridge the joints with a ground conductor bonded to the conduit on each side of the joint. Also bond the conduits to the drive enclosure and motor frame. Use separate conduits for input power, motor, brake resistor, and control wiring. When conduit is employed, type MC continuous corrugated aluminum armor cable or shielded cable is not required. A dedicated ground cable is always required.

Note: Do not run motor wiring from more than one drive in the same conduit.

Armored cable / shielded power cable

Six-conductor (three phases and three ground) type MC continuous corrugated aluminum armor cable with symmetrical grounds is available from the following suppliers (trade names in parentheses):

- Anixter Wire & Cable (Philsheath)
- BICC General Corp (Philsheath)
- Rockbestos Co. (Gardex)
- Oaknite (CLX).

Shielded power cables are available from the following suppliers:

- Belden
- LAPPKABEL (ÖLFLEX)
- Pirelli.

Selecting the control cables

■ Shielding

All control cables must be shielded.

Use a double-shielded twisted pair cable (figure a below) for analog signals. Employ one individually shielded pair for each signal. Do not use common return for different analog signals.

A double-shielded cable is the best alternative for low-voltage digital signals but single-shielded (b) twisted pair cable is also acceptable.

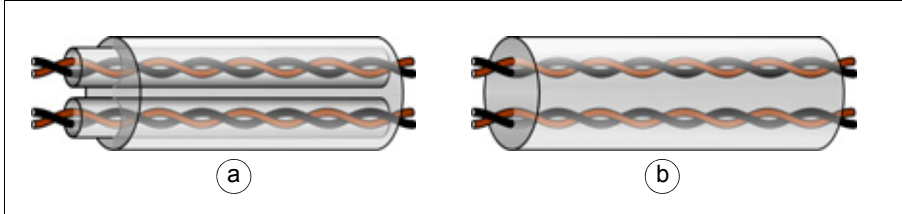

■ Signals in separate cables

Run analog and digital signals in separate, shielded cables.

Do not mix 24 V AC/DC and 115/230 V AC signals in the same cable.

■ Signals allowed to be run in the same cable

Relay-controlled signals, providing their voltage does not exceed 48 V, can be run in the same cables as digital input signals. The relay-controlled signals should be run as twisted pairs.

■ Relay cable

The cable type with braided metallic screen (for example ÖLFLEX by LAPPKABEL, Germany) has been tested and approved by the manufacturer.

■ Control panel cable

In remote use, the cable connecting the control panel to the drive must not exceed 100 m (330 ft). If multiple drives are connected, the total length of the panel bus must not exceed 100 m (330 ft).

The cable type tested and approved by the manufacturer is used in control panel option kits. Suitable cables are CAT 5e unshielded or shielded twisted pair cables.

■ Drive composer PC tool cable

Connect the Drive composer PC tool to the drive through the USB port of the control panel. Use a USB type A (PC) - type B (control panel) cable. The maximum length of the cable is 3 m (9.8 ft).

Routing the cables

General rules

Route the motor cable away from other cable routes. Motor cables of several drives can be run in parallel installed next to each other. The motor cable, input power cable and control cables should be installed on separate trays. Avoid long parallel runs of motor cables with other cables in order to decrease electromagnetic interference caused by the rapid changes in the drive output voltage.

Where control cables must cross power cables, make sure they are arranged at an angle as near to 90 degrees as possible. Do not run extra cables through the drive.

The cable trays must have good electrical bonding to each other and to the grounding electrodes. Aluminum tray systems can be used to improve local equalizing of potential.

A diagram of the cable routing is shown below.

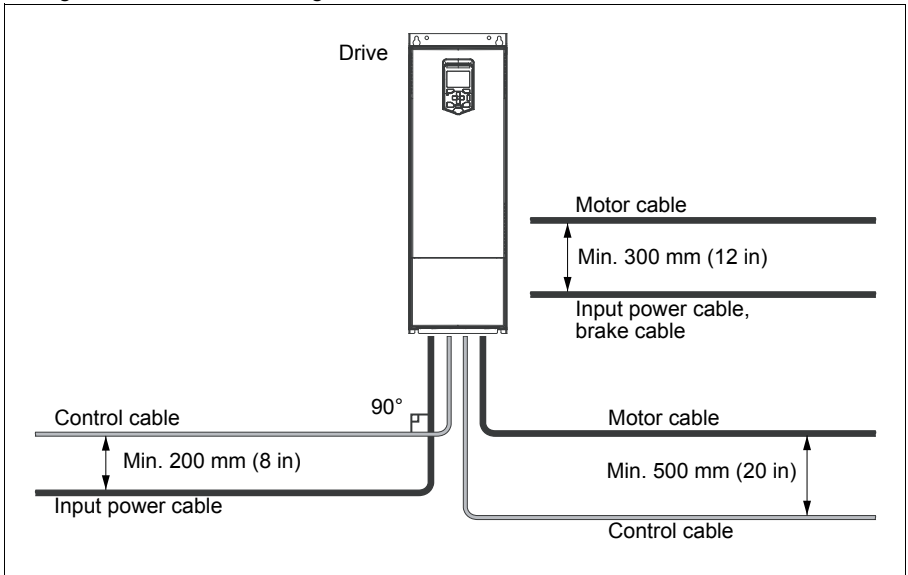

■ Separate control cable ducts

Lead 24 V and 230 V (120 V) control cables in separate ducts unless the 24 V cable is insulated for 230 V (120 V) or insulated with an insulation sleeving for 230 V (120 V).

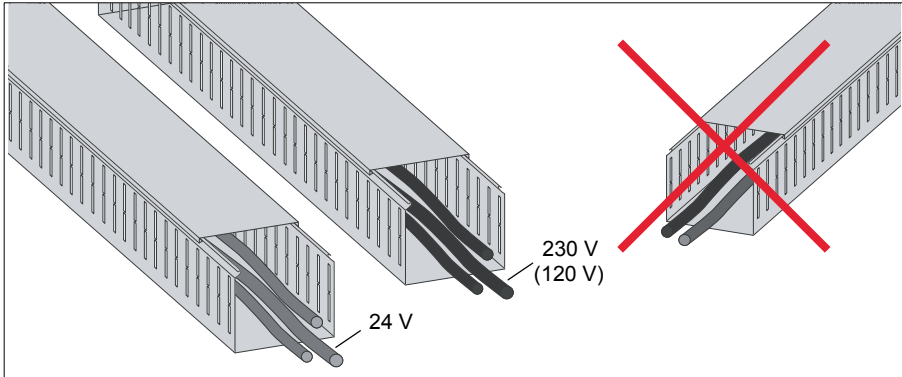

■ Continuous motor cable shield or enclosure for equipment on the motor cable

To minimize the emission level when safety switches, contactors, connection boxes or similar equipment are installed on the motor cable between the drive and the motor:

- European Union: Install the equipment in a metal enclosure with 360 degree grounding for the shields of both the incoming and outgoing cable, or connect the shields of the cables otherwise together.
- US: Install the equipment in a metal enclosure in a way that the conduit or motor cable shielding runs consistently without breaks from the drive to the motor.

Implementing thermal overload and short-circuit protection

■ Protecting the drive and input power cable in short-circuits

Protect the drive and input cable with fuses as follows:

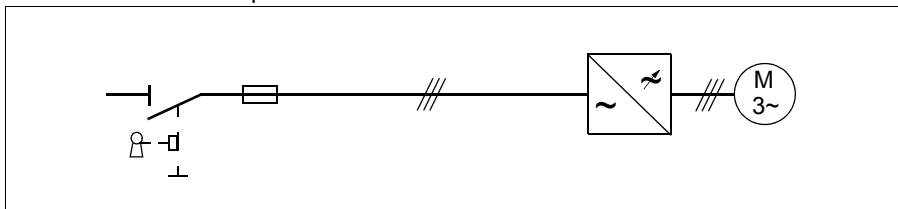

Size the fuses at the distribution board according to instructions given in chapter [Technical data](#) on page 163. The fuses will protect the input cable in short-circuit situations, restrict drive damage and prevent damage to adjoining equipment in case of a short-circuit inside the drive.

Note: If you want to use circuit breakers, contact ABB. Fuses must be used with circuit breakers in the USA.

■ Protecting the motor and motor cable in short-circuits

The drive protects the motor cable and motor in a short-circuit situation when the motor cable is sized according to the nominal current of the drive. No additional protection devices are needed.

■ Protecting the drive and the input power and motor cables against thermal overload

The drive protects itself and the input and motor cables against thermal overload when the cables are sized according to the nominal current of the drive. No additional thermal protection devices are needed.



WARNING! If the drive is connected to multiple motors, use a separate circuit breaker or fuses for protecting each motor cable and motor against overload. The drive overload protection is tuned for the total motor load. It may not trip due to an overload in one motor circuit only

■ Protecting the motor against thermal overload

According to regulations, the motor must be protected against thermal overload and the current must be switched off when overload is detected. The drive includes a motor thermal protection function that protects the motor and switches off the current when necessary. Depending on a drive parameter value, the function either monitors a calculated temperature value (based on a motor thermal model) or an actual

temperature indication given by motor temperature sensors. The user can tune the thermal model further by feeding in additional motor and load data.

The most common temperature sensors are:

- motor sizes IEC180...225: thermal switch, eg, Klixon
- motor sizes IEC200...250 and larger: PTC or Pt100.

For more information, see the firmware manual.

Protecting the drive against ground faults

The drive is equipped with an internal ground fault protective function to protect the unit against ground faults in the motor and motor cable. This is not a personnel safety or a fire protection feature. The ground fault protective function can be reduced with a parameter 31.20 Earth fault.

■ Residual current device compatibility

The drive is suitable to be used with residual current devices of Type B.

Note: The EMC filter of the drive includes capacitors connected between the main circuit and the frame. These capacitors and long motor cables increase the ground leakage current and may cause fault current circuit breakers to function.

Implementing the Emergency stop function

For safety reasons, install the emergency stop devices at each operator control station and at other operating stations where emergency stop may be needed. Design the emergency stop according to relevant standards.

Note: Pressing the stopkey  on the control panel of the drive does not generate an emergency stop of the motor or separate the drive from dangerous potential.

Implementing the Safe torque off function

See chapter [The Safe torque off function](#) on page 213.

Implementing the safety functions provided with the FSO safety functions module (options +Q972 and +Q973)

The drive can be equipped with a safety functions module as factory installed (option +Q973 or +Q972). The module is also available as a retrofit kit. The safety functions module enables the implementation of functions such as Safe brake control (SBC), Safe stop 1 (SS1), Safe stop emergency (SSE), Safely limited speed (SLS) and Safe maximum speed (SMS).

The settings of the FSO-xx are at default when delivered from the factory. The wiring of the external safety circuit and configuration of the FSO-xx module are the responsibility of the machine builder.

The FSO-xx reserves the standard Safe torque off (STO) connection of the drive control unit. STO can still be utilized by other safety circuits through the FSO-xx.

For the installation of the safety functions module, see section [Installation of safety functions modules](#) on page 108. For wiring instructions, safety data and more information on the option, see *FSO-12 safety functions module user's manual* (3AXD50000015612 [English]) or *FSO-21 safety functions module user's manual* (3AXD50000015614 [English]).

■ Declaration of Conformity

See page 195.

Implementing the ATEX-certified Safe motor disconnection function (option +Q971)

With option +Q971, the drive supplies ATEX-certified safe motor disconnection without contactor that uses the drive Safe torque off function. For more information, see *ACS880 ATEX-certified Safe disconnection function application guide* (3AUA0000132231 [English]). See also section [Deratings for special settings in the drive control program](#) on page 169.

Implementing the undervoltage control (power-loss ride-through)

See the firmware manual.

Using a safety switch between the drive and the motor

ABB recommends to install a safety switch between the permanent magnet motor and the drive output. This is needed to isolate the motor from the drive during maintenance work on the drive.

Using a contactor between the drive and the motor

Implementing the control of the output contactor depends on how you select the drive to operate.

When you have selected to use

- DTC control mode and motor ramp stop,

open the contactor as follows:

1. Give a stop command to the drive.
1. Wait until the drive decelerates the motor to zero speed.
2. Open the contactor.

When you have selected to use

- DTC control mode and motor coast stop; or scalar control mode,

open the contactor as follows:

1. Give a stop command to the drive.
2. Open the contactor.



WARNING! When the DTC control mode is in use, never open the output contactor while the drive controls the motor. The DTC control operates extremely fast, much faster than it takes for the contactor to open its contacts. When the contactor starts opening while the drive controls the motor, the DTC control will try to maintain the load current by immediately increasing the drive output voltage to the maximum. This will damage or destroy the contactor completely.

Protecting the contacts of relay outputs

Inductive loads (relays, contactors, motors) cause voltage transients when switched off.

It is highly recommended that inductive loads are equipped with noise attenuating circuits (varistors, RC filters [AC] or diodes [DC]) in order to minimize the EMC emission at switch-off. If not suppressed, the disturbances may connect capacitively or inductively to other conductors in the control cable and form a risk of malfunction in other parts of the system.

Install the protective component as close to the inductive load as possible. Do not install protective components at the relay outputs.

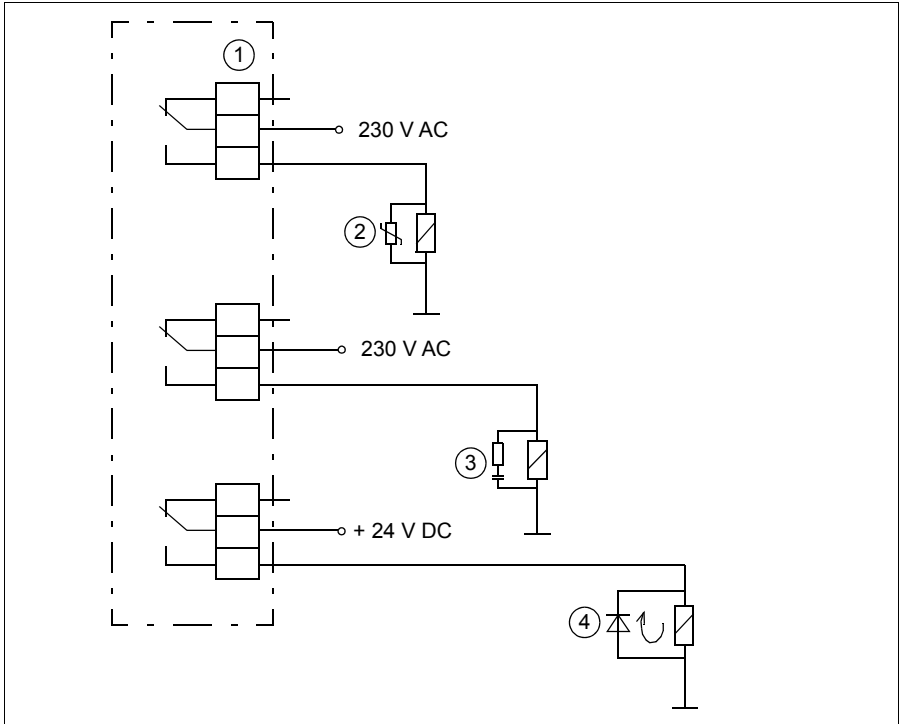

1	Relay outputs
2	Varistor
3	RC filter
4	Diode

Implementing a motor temperature sensor connection



WARNING! IEC 60664 and IEC 61800-5-1 require double or reinforced insulation between live parts and the surface of accessible parts of electrical equipment which are either non-conductive or conductive but not connected to the protective earth.

To connect a motor temperature sensor and other similar components to the drive, you have four alternatives:

1. If there is double or reinforced insulation between the sensor and the live parts of the motor, you can connect the sensor directly to the **analog/digital** inputs of the drive.
 2. If there is basic insulation between the sensor and the live parts of the motor, you can connect the sensor to the analog/digital inputs of the drive if all circuits connected to the drive's digital and analog inputs (typically extra-low voltage circuits) are protected against contact and insulated with basic insulation from other low-voltage circuits. The insulation must be rated for the same voltage level as the drive main circuit. Note that extra-low voltage circuits (such as 24 V DC) typically do not meet these requirements.
 3. You can connect the sensor to the drive via an option module. The sensor and the module must form a double or reinforced insulation between the motor live parts and the drive control unit. See section [Connection of motor temperature sensor to the drive via an option module](#) (page 73).
 4. You can connect the sensor to a digital input of the drive via a customer's external relay. The sensor and the relay must form a double or reinforced insulation between the motor live parts and the drive control unit. See section [Connection of motor temperature sensor to the drive via a relay](#) (page 74).
-

■ Connection of motor temperature sensor to the drive via an option module

This table shows:

- option module types that you can use for the motor temperature sensor connection
- insulation or isolation level that each option module forms between its temperature sensor connector and other connectors
- temperature sensor types that you can connect to each option module
- temperature sensor insulation requirement in order to form, together with the insulation of the option module, a double or reinforced insulation between the motor live parts and the drive control unit.

Option module		Temperature sensor type			Temperature sensor insulation requirement
Type	Insulation/Isolation	PTC	KTY	Pt100 , Pt100 0	
FIO-11	Galvanic isolation between sensor connector and other connectors (including drive control unit connector)	-	X	X	Reinforced insulation
FEN-xx	Galvanic isolation between sensor connector and other connectors (including drive control unit connector)	X	X	-	Reinforced insulation
FAIO-01	Basic insulation between sensor connector and drive control unit connector. No insulation between sensor connector and other IO connectors.	X	X	X	Basic insulation. Connectors of extension module other than sensor connector must be left unconnected.
FPTC-xx ¹⁾	Reinforced insulation between sensor connector and other connectors (including drive control unit connector).	X	-	-	No special requirement

1) Suitable for use in safety functions (SIL2 / PL c rated)

More information:

- *FPTC-01 thermistor protection module (option +L536) for ACS880 drives user's manual (3AXD50000027750 [English])*
- *FPTC-02 ATEX-certified thermistor protection module Ex II (2) GD (option +L537+Q971) for ACS880 drives user's manual (3AXD50000027782 [English]).*

■ Connection of motor temperature sensor to the drive via a relay

PTC alternative A. This table shows the insulation of the factory-installed relay (plus code option), insulation requirement for a customer’s external relay, and the insulation requirement for the sensor to fulfill decisive voltage class A (double insulation) of IEC 60800-5-1.

PTC relay		Temperature sensor insulation requirement
Type	Insulation	
External relay	Basic insulation 6 kV	Basic insulation

PTC alternative B. Decisive voltage class B of IEC 60800-5-1 (basic insulation) is provided with a 6 kV relay. Circuits connected to all motor protection relay inputs and outputs must be protected against direct contact.

Pt100 relay		Temperature sensor insulation requirement between sensor and live parts of motor
Type	Insulation	
External relay	Basic insulation 6 kV	Basic insulation

Pt100 alternative B. Decisive voltage class B of IEC 60800-5-1 (basic insulation) can be achieved when there is basic insulation between the sensor and live parts of the motor. Circuits connected to all motor protection relay inputs and outputs must be protected against direct contact.

6

Electrical installation – IEC

Contents of this chapter

The chapter describes how to check the insulation of the assembly and the compatibility with grounding systems. It then shows how to connect the power and control cables, install optional modules and connect a PC.

Warnings



WARNING! Obey the instructions in chapter [Safety instructions](#) on page 13. If you ignore them, injury or death, or damage to the equipment can occur.

Make sure that the drive is disconnected from the input power during installation. If you need to disconnect the drive, wait for 5 minutes after disconnecting the input power before you start the work.



Required tools

- wire stripper
 - screwdriver and/or wrench with a set of suitable bits
-

Grounding the motor cable shield at the motor end

Ground the motor cable shield at the motor end. For minimum radio frequency interference, ground the motor cable shield 360 degrees at the cable entry of the motor terminal box.

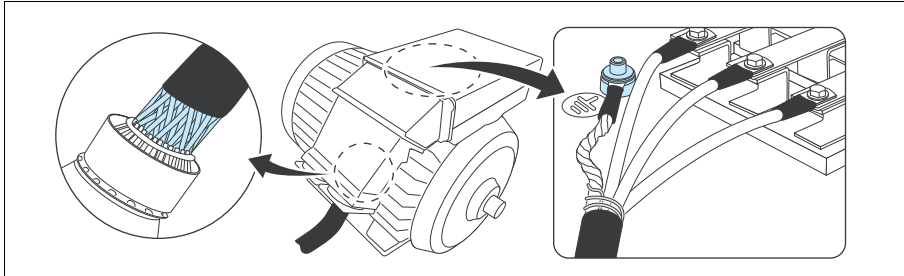

Checking the insulation of the assembly

■ Drive

Do not make any voltage tolerance or insulation resistance tests on any part of the drive as testing can damage the drive. Every drive has been tested for insulation between the main circuit and the chassis at the factory. Also, there are voltage-limiting circuits inside the drive which cut down the testing voltage automatically.

■ Input power cable

Check the insulation of the input cable according to local regulations before connecting it to the drive.

■ Motor and motor cable

Check the insulation of the motor and motor cable as follows:

1. Stop the drive and do the steps in section [Precautions before electrical work](#) on page [16](#) before you start the work.
2. Check that the motor cable is disconnected from the drive output terminals T1/U, T2/V and T3/W.
3. Measure the insulation resistance between the phase conductors and between each phase conductor and the Protective Earth conductor. Use a measuring voltage of 1000 V DC. The insulation resistance of a motor must exceed 100 Mohm (reference value at 25 °C or 77 °F). For the insulation resistance of other motors, please consult the manufacturer's instructions.

Note: Moisture inside the motor casing will reduce the insulation resistance. If moisture is suspected, dry the motor and repeat the measurement.

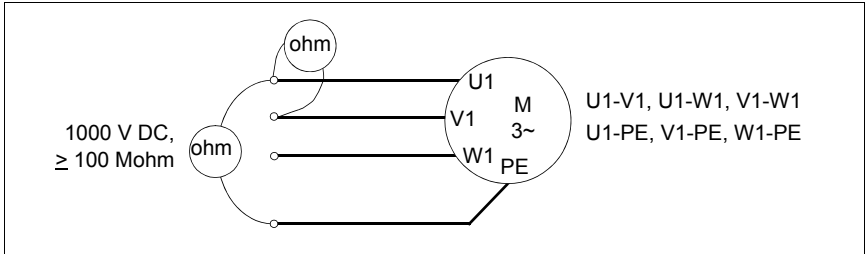

■ Brake resistor assembly

Check the insulation of the brake resistor assembly (if present) as follows:

1. Stop the drive and do the steps in section [Precautions before electrical work](#) on page 16 before you start the work.
2. Check that the resistor cable is connected to the resistor, and disconnected from the brake chopper output terminals.
3. At the brake chopper end, connect the R+ and R- conductors of the resistor cable together. Measure the insulation resistance between the combined conductors and the PE conductor by using a measuring voltage of 1 kV DC. The insulation resistance must be higher than 1 Mohm.

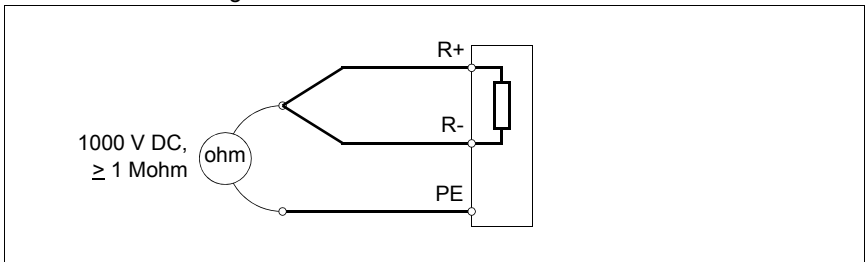

Checking the compatibility with IT (ungrounded), corner-grounded delta, midpoint-grounded delta, and TT systems

■ EMC filter option +E200 or +E202

A drive with EMC filter options +E200 and +E202 connected can be installed to a symmetrically grounded TN-S system. If you install the drive to another system, you may need to disconnect the EMC filter. See sections [When to disconnect EMC filter \(options E200 and +E202\) or ground-to-phase varistor: TN-S, IT, corner-grounded delta, and midpoint-grounded delta systems](#) on page 79 and [Guidelines for installing the drive to a TT system](#) on page 80.



WARNING! Do not install the drive with EMC filter options +E200 and +E202 connected to a system that the filter is not suitable for. This can cause danger, or damage the drive.

Note: When EMC filter +E200 and +E202 is disconnected, the drive EMC compatibility is considerably reduced.

■ Ground-to-phase varistor

A drive with the ground-to-phase varistor connected can be installed to a symmetrically grounded TN-S system. If you install the drive to another system, you may need to disconnect the varistor. See sections [When to disconnect EMC filter \(options E200 and +E202\) or ground-to-phase varistor: TN-S, IT, corner-grounded delta, and midpoint-grounded delta systems](#) on page 79 and [Guidelines for installing the drive to a TT system](#) on page 80.



WARNING! Do not install the drive with the ground-to-phase varistor connected to a system that the varistor is not suitable for. If you do, the varistor circuit can be damaged.

■ When to disconnect EMC filter (options E200 and +E202) or ground-to-phase varistor: TN-S, IT, corner-grounded delta, and midpoint-grounded delta systems

Frame size	Symmetrically grounded TN-S systems ¹	Corner-grounded and midpoint-grounded delta systems ²	IT systems (ungrounded or high-resistance grounded [>30 ohms]) ³
R3	Do not disconnect EMC or VAR screws	Do not disconnect EMC or VAR screws	Disconnect EMC and VAR screws.
R6	Do not disconnect EMC or VAR screws	See Note 1 below.	Disconnect EMC AC, EMC DC and VAR screws.
R8	Do not disconnect EMC or VAR screws	Disconnect EMC and VAR screws	Disconnect EMC and VAR screws.

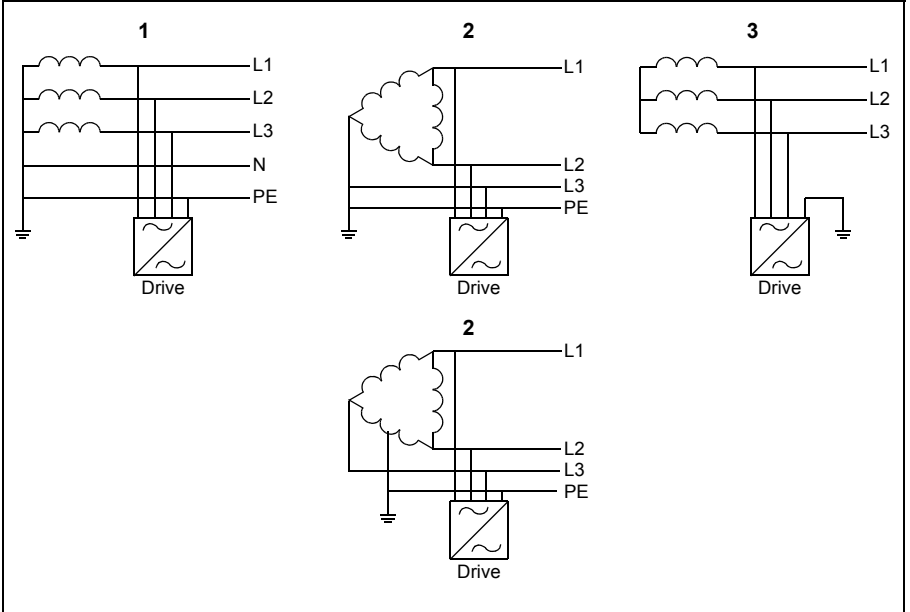

Note 1: Frames R3 and R6 are evaluated for use on corner-grounded systems and midpoint-grounded delta systems by UL standards. Disconnect EMC DC screw. Do not disconnect EMC AC or VAR screws. Frames R3 and R6 are not evaluated by IEC standards for use on corner-grounded or midpoint-grounded systems.

Note 2: These are the EMC filter and varistor screws of different drive frame sizes.

Frame size	EMC filter (+E200, +E202) screws	Ground-to-phase varistor screws
R3	EMC	VAR
R6	EMC AC, EMC DC	VAR



R8	EMC DC	VAR*
----	--------	------

*) VAR screw functions also as EMC AC screw in frame R8.

■ Guidelines for installing the drive to a TT system

The drive can be connected to a TT system under these conditions:

1. Residual current device has been installed in the supply system.
2. These screws have been disconnected. Otherwise EMC filter and ground-to-phase varistor capacitor leakage current will cause the residual current device to trip.

Frame size	EMC filter (+E200, +E202) screws	Ground-to-phase varistor screws
R3	EMC	VAR
R6	EMC AC, EMC DC	VAR
R8	EMC DC	VAR*

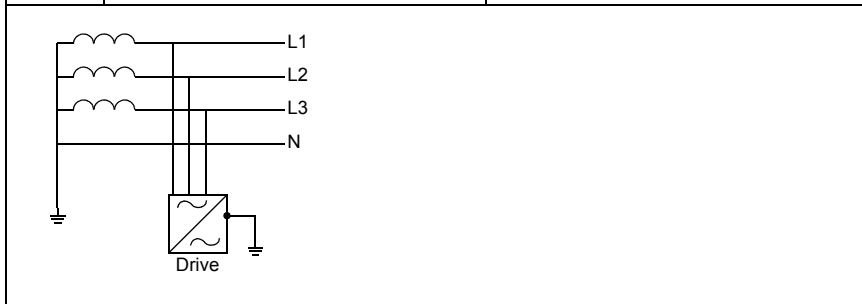

3AXD1000681917

Note:

- Because the EMC filter screws have been disconnected, ABB does not guarantee the EMC category.
- ABB does not guarantee the functioning of the ground leakage detector built inside the drive.
- In large systems the residual current device can trip without a real reason.

■ Identifying different types of electrical power systems

To identify the electrical power system type, find out the supply transformer connection. If that is not possible, measure these voltages at the distribution board before you connect power to the drive:

1. input voltage line to line (U_{L-L})
2. input voltage line 1 to ground (U_{L1-G})
3. input voltage line 2 to ground (U_{L2-G})
4. input voltage line 3 to ground (U_{L3-G}).

The line-to-ground voltages in relation to the line-to-line voltage of the electrical power system types are shown below.

U_{L-L}	U_{L1-G}	U_{L2-G}	U_{L3-G}	Electrical power system type
X	$0.58 \cdot X$	$0.58 \cdot X$	$0.58 \cdot X$	Symmetrically grounded TN system (TN-S system)
X	$1.0 \cdot X$	$1.0 \cdot X$	0	Corner-grounded delta system (nonsymmetrical)
X	$0.5 \cdot X$	$0.5 \cdot X$	$0.57 \cdot X$	Midpoint-grounded delta system (nonsymmetrical)
X	Varying level versus time	Varying level versus time	Varying level versus time	IT systems (ungrounded or high-resistance-grounded [>30 ohms]) nonsymmetrical



■ **Disconnecting internal EMC filter (option +E200 or +E202) and ground-to-phase varistor – frame R3**

1. Stop the drive and do the steps in section *Precautions before electrical work* on page 16 before you start the work.
2. Remove the front cover. See page 86.
3. Remove the EMC screw.
4. Remove the VAR screw.

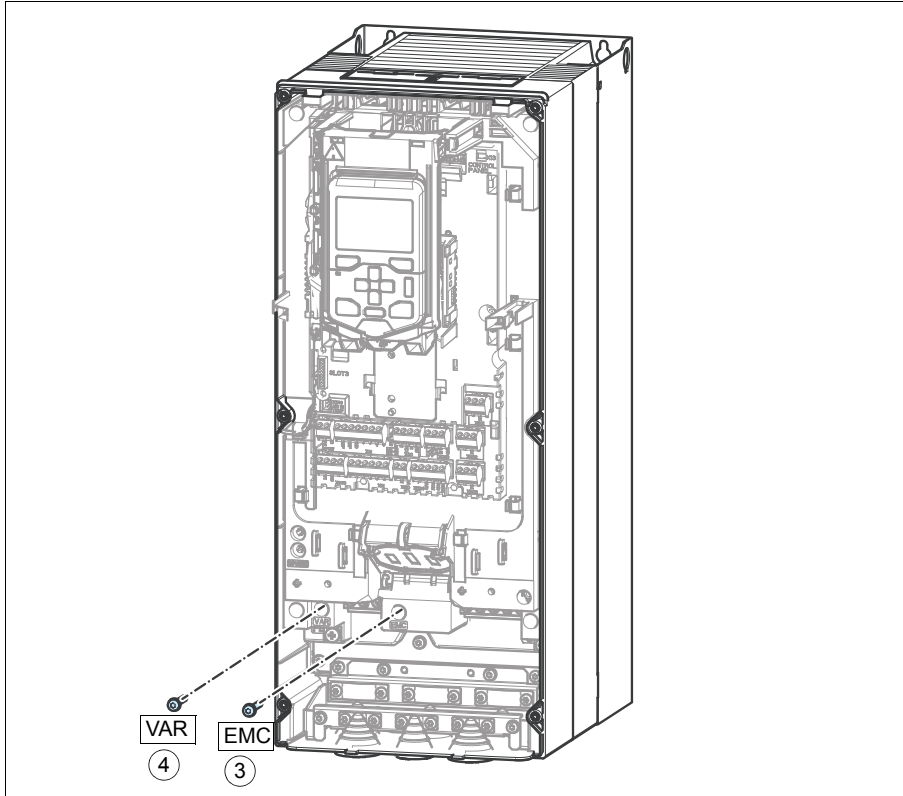

■ Disconnecting internal EMC filter (option +E200 or +E202) and ground-to-phase varistor – frame R6

1. Stop the drive and do the steps in section *Precautions before electrical work* on page 16 before you start the work.
2. Remove the front cover. See page 86.
3. Remove the VAR screw.
4. Remove the EMC AC and/or EMC DC screws.

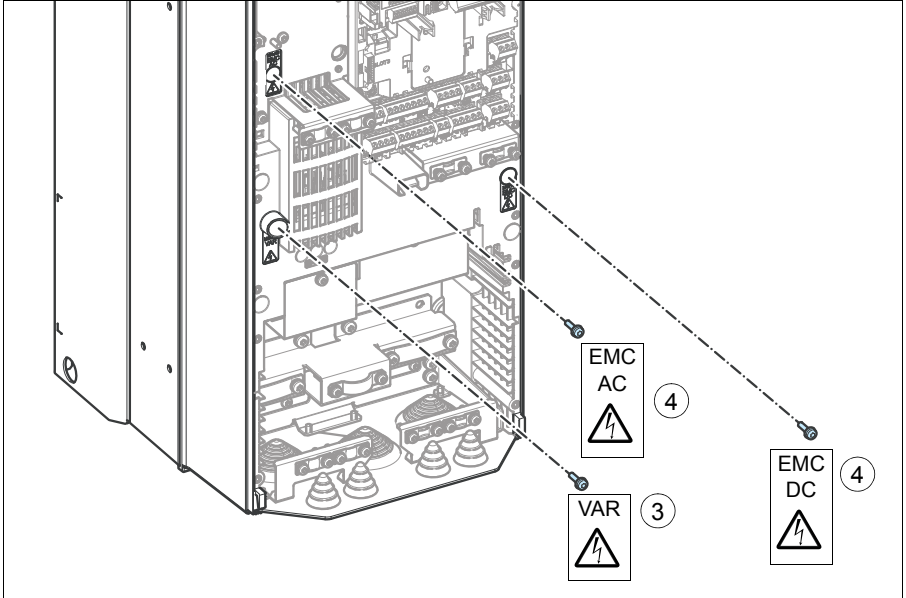

■ Disconnecting internal EMC filter and ground-to-phase varistor – frame R8

Disconnect the EMC filter (option +E200 or +E202) and/or varistor when necessary. See [When to disconnect EMC filter \(options E200 and +E202\) or ground-to-phase varistor: TN-S, IT, corner-grounded delta, and midpoint-grounded delta systems](#) on page 79.

1. Stop the drive and do the steps in section [Precautions before electrical work](#) on page 16 before you start the work.
2. Remove the front cover if it is not already removed. See page 86.
3. Remove the VAR screw.
4. Remove the EMC screw.

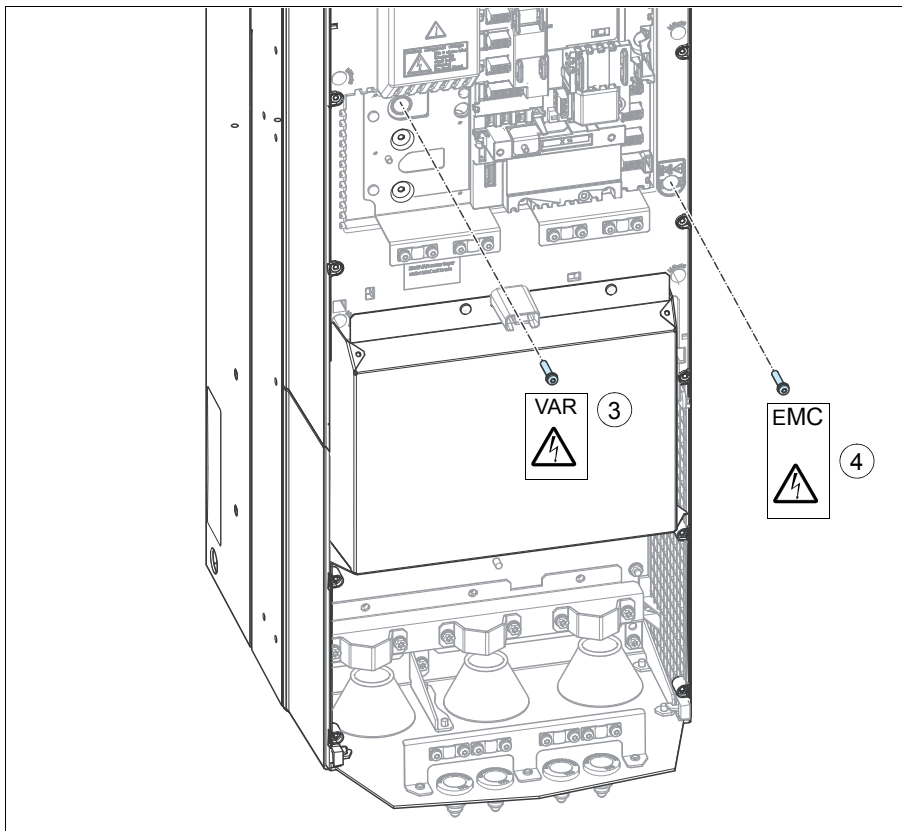

Connecting the power cables

Connection diagram

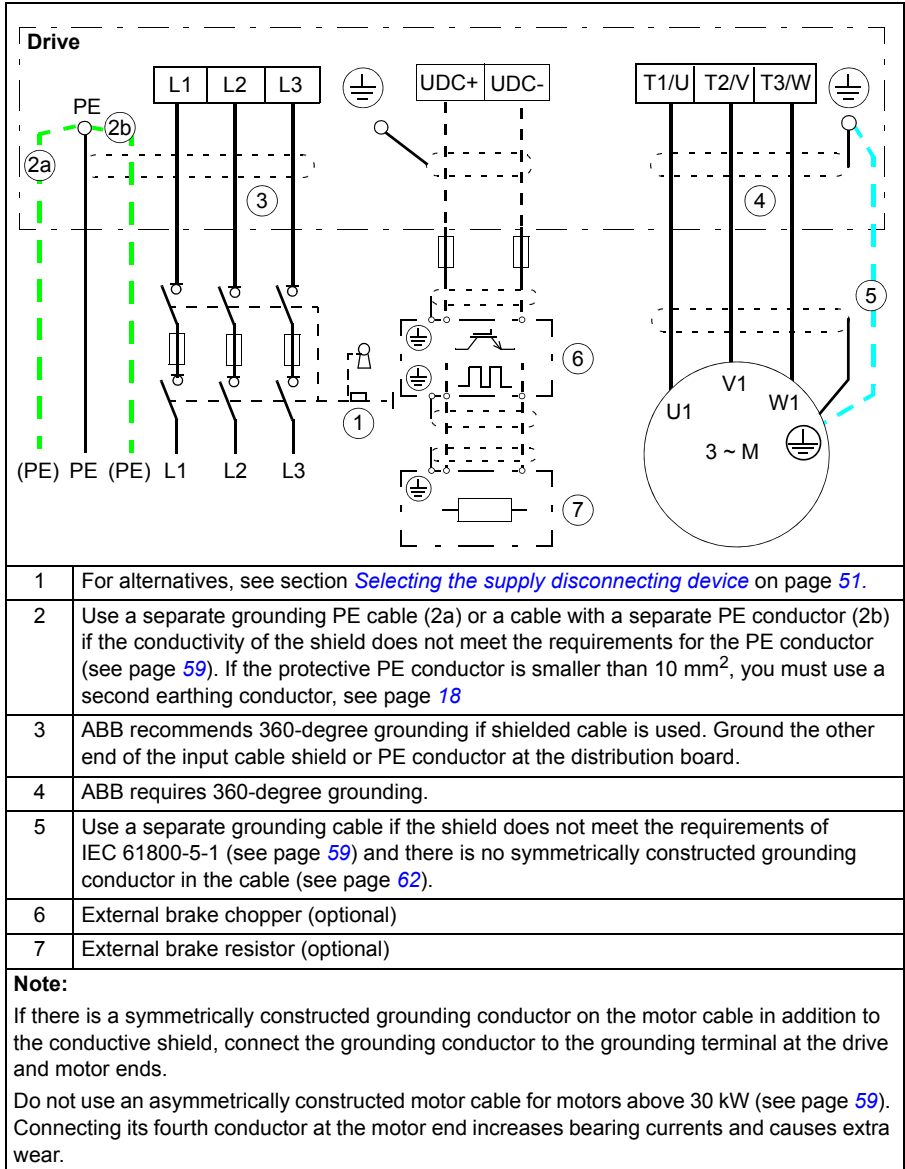

■ Connection procedure

The procedure of connecting the power cables to the standard drive is described below. For the procedure with UK gland plate (option +H358), see also *UK gland plate installation guide* (3AXD50000110711 [English]).

1. For frame R3: Remove the front cover:

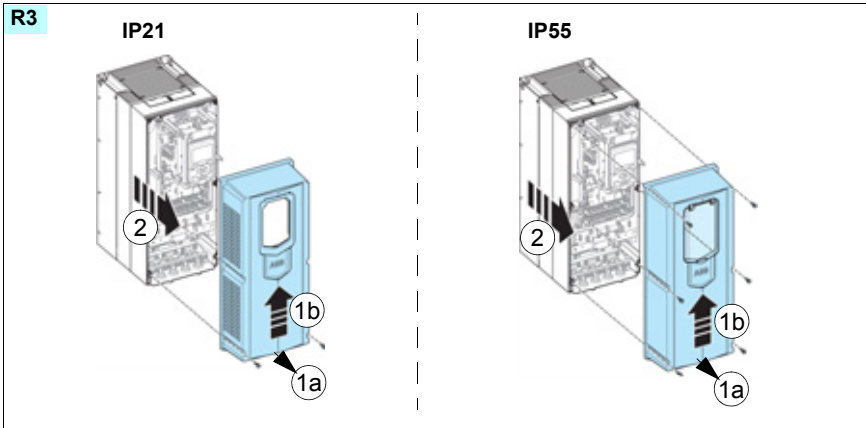

For frame R6 and R8 (IP21): Remove the covers as follows:

- To remove the middle front cover, loosen the retaining screw with a screwdriver. Remove the cover.
- Remove the lower front cover

For frame R6 and R8 (IP55): Remove the covers as follows:

- Loosen the screws that attach the front cover to the frame.
- Remove the cover.



R6, R8

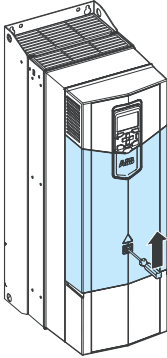

IP21

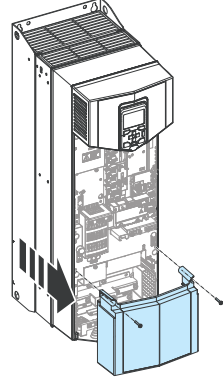
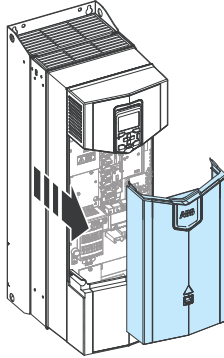

IP55

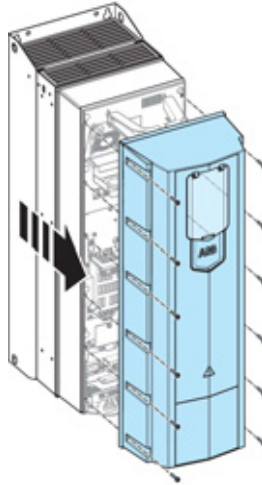

WARNING! Make sure you have disconnected the EMC filter and/or ground-to-phase varistor when necessary. See [Checking the compatibility with IT \(ungrounded\), corner-grounded delta, midpoint-grounded delta, and TT systems](#) page 78.

2. Attach the residual voltage warning sticker in the local language.

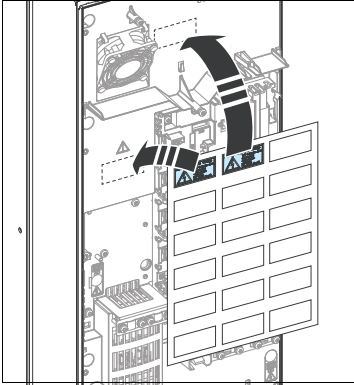

3. For frames R6 and R8: Remove the shroud on the power cable terminals,

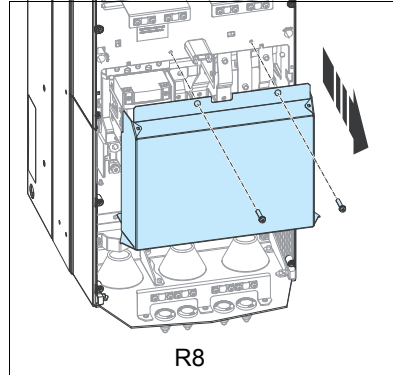
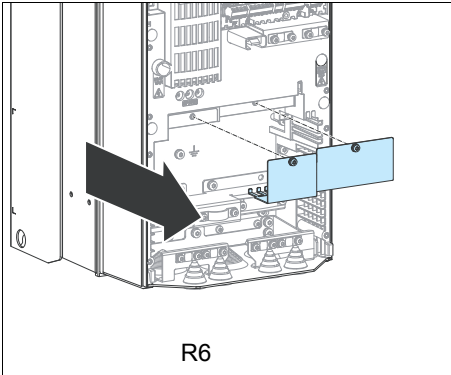

4. For frame R8: For easier installation, you can remove the side plates.

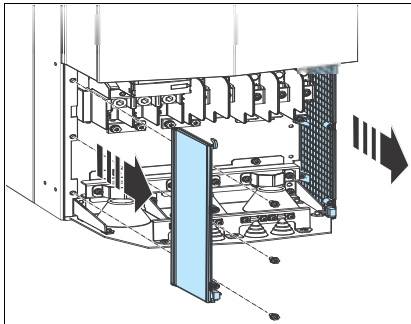

5. Remove the rubber grommets of the cables to be installed from the cable entry plate.



6. Cut an adequate hole into the rubber grommet. Slide the grommet onto the cable.

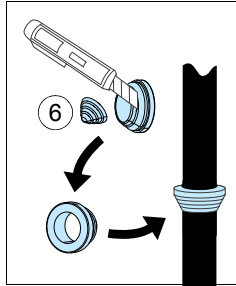
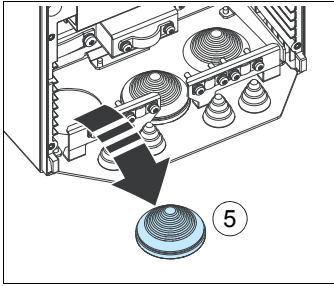

7. Prepare the ends of the cables as illustrated in the figure. If you use aluminum cables, put grease to the peeled aluminum cable before connecting it to the drive. Two different motor cable types are shown in the figures (6a, 6b). **Note:** The bare shield will be grounded 360 degrees.

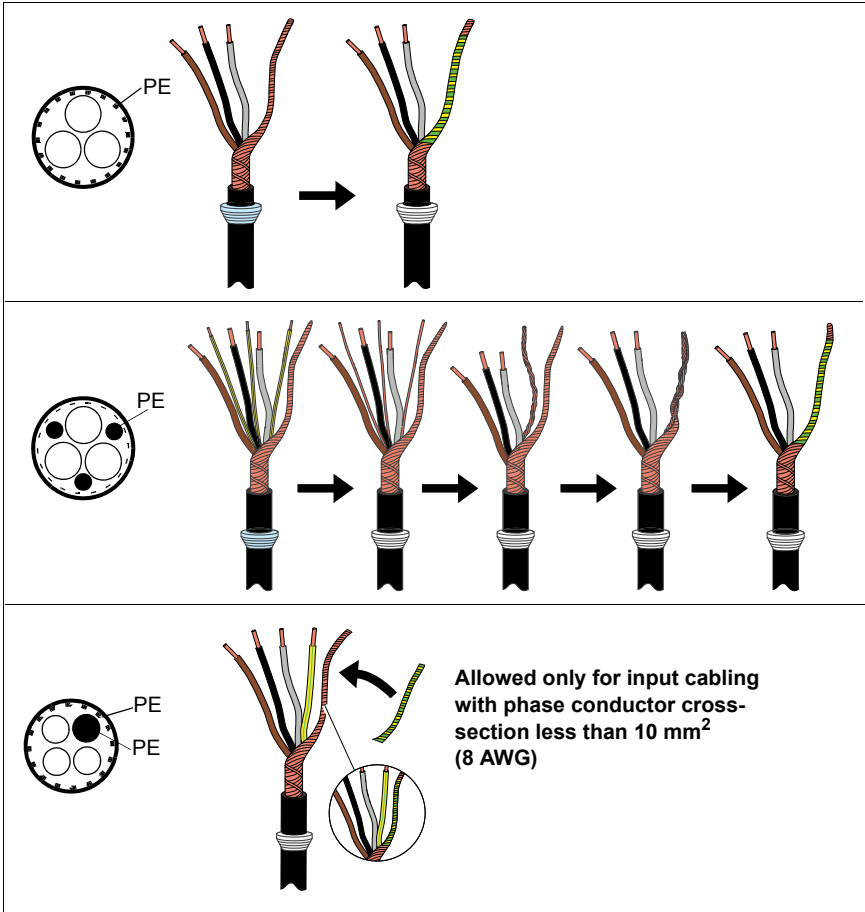

8. Put the cable through the hole of the cable entry plate and attach the grommet to the hole.
9. Connect the cables:
 - Ground the shield 360 degrees by tightening the clamp of the power cable grounding shelf onto the stripped part of the cable.
 - Connect the twisted shield of the cable to the grounding terminal.
 - Connect the additional PE conductors (if any).
 - Connect the phase conductors of the motor cable to the T1/U, T2/V and T3/W terminals and the phase conductors of the input cable to the T1, T2 and T3 terminals.
 - If DC cables are present, cut off one phase conductor and connect the remaining conductors to the UDC+ and UDC- terminals.

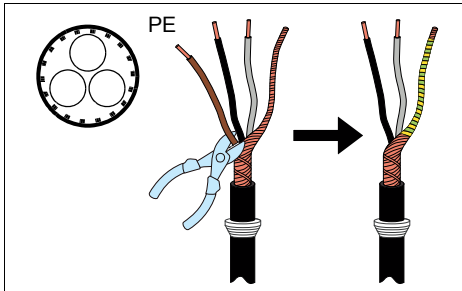

- Tighten the screws to the torque given below in the installation drawing.



R3

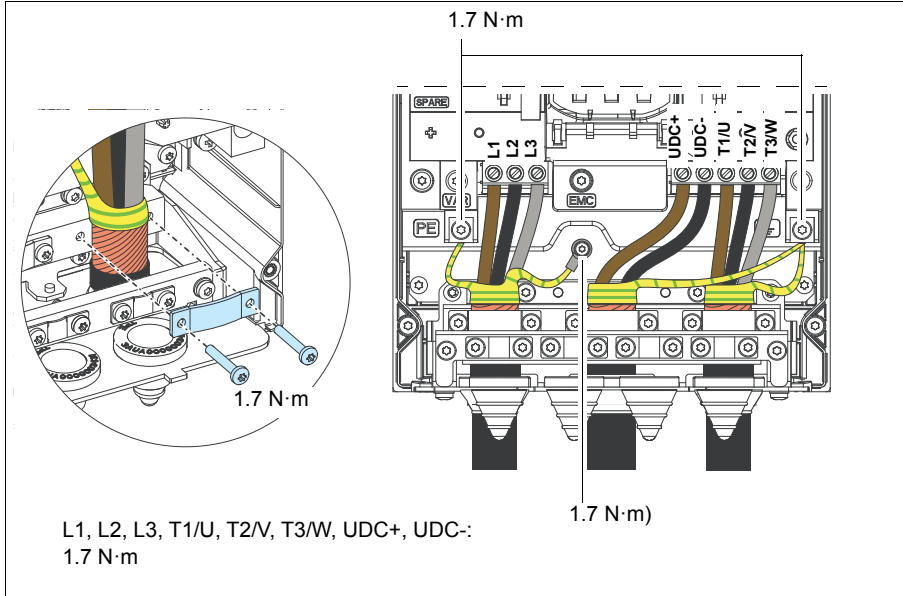

R6

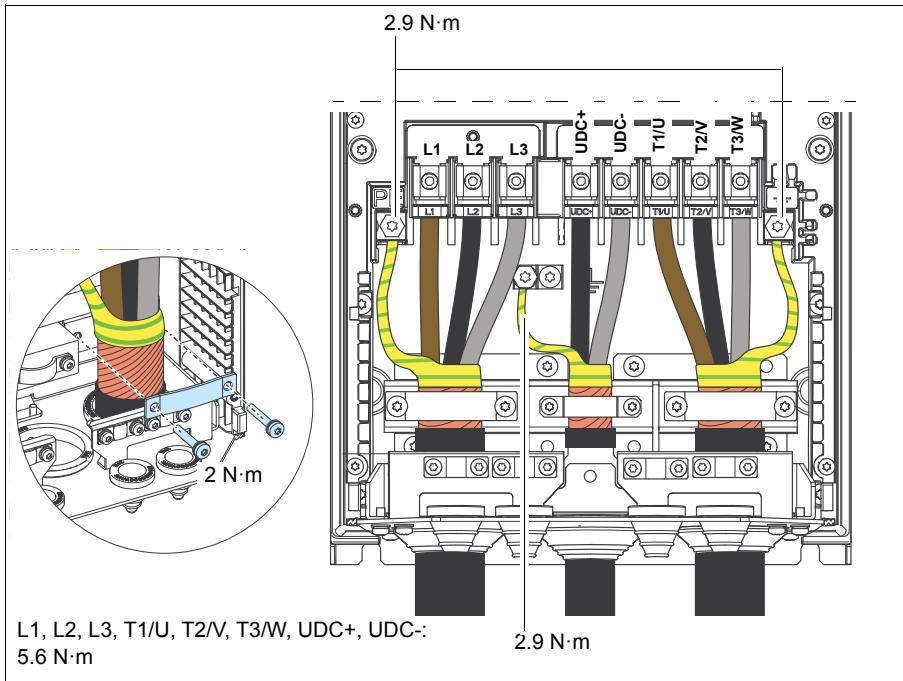

R8

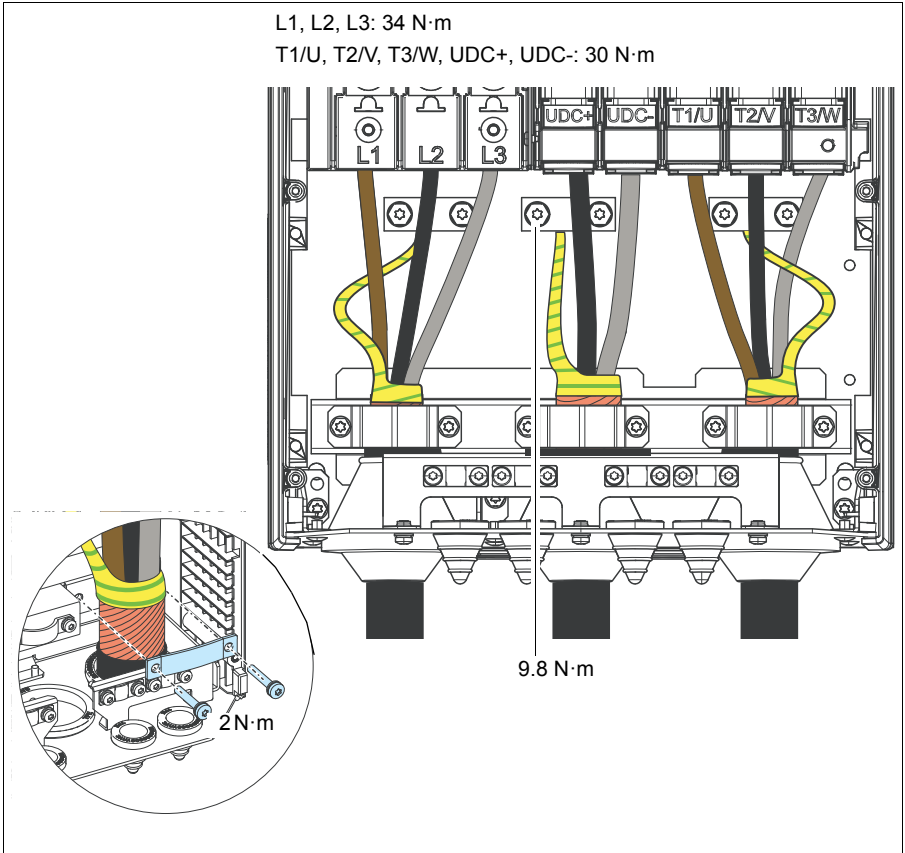

Note 1 for frame R8: Install the side plates if removed.

Note 2 for frame R8: The motor cable connectors can be detached. For the instructions, see section [R8 power cable connection if you detach the motor cable connectors](#) on page 95.

10. For frame R6 types bigger than -040A-x: Cut tabs in the shroud for the installed cables. For frame R8: Knock out holes in the shroud for the input cables.

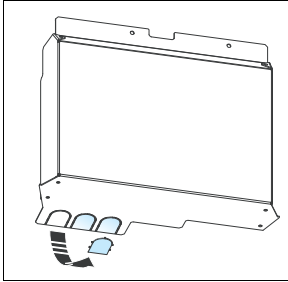

11. Install the shroud onto the power cable connection terminals.

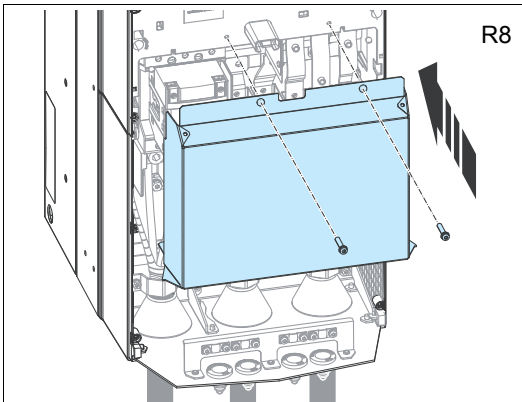
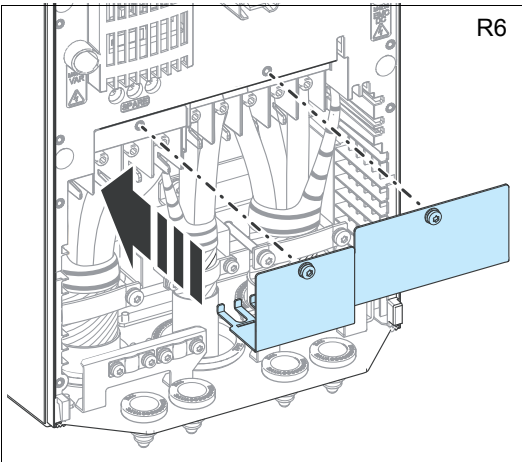

R8 power cable connection if you detach the motor cable connectors

The motor cable connectors of frame R8 are detachable. If you detach them, you can connect the motor cables with cable lugs as follows:

- Remove the nut that attaches the connector to the terminal post and remove the connector.
- Attach the conductor to a cable lug. Put the cable lug onto the post.
- Tighten the nut to a torque of 30 N·m.

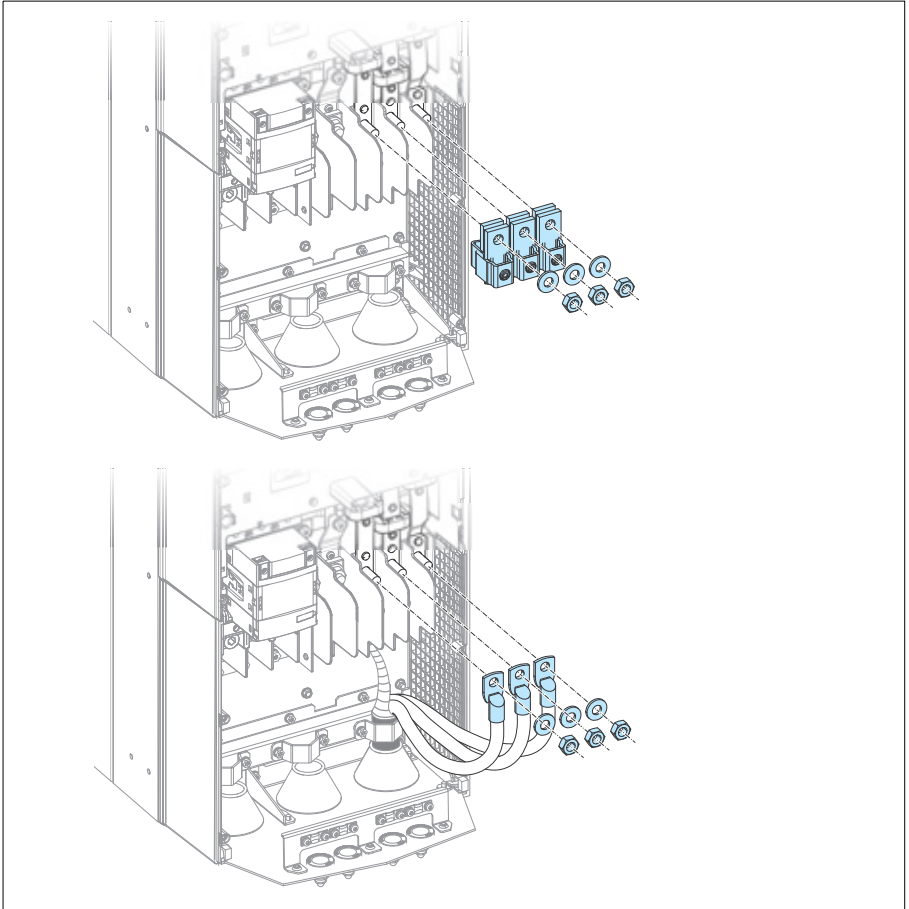

Connecting the control cables

See section [Default I/O connection diagram](#) on page 97 for the default I/O connections of the drive.

Connect the cables as described under [Control cable connection procedure \(IEC\)](#) on page 101.



WARNING! Do not connect the +24 V AC cable to the control unit ground when the control unit is powered using an external 24 V AC supply.



Default I/O connection diagram

Wire sizes:
0.5 ... 2.5 mm²
Tightening
torques: 0.5 N·m
for both
stranded and
solid wiring.

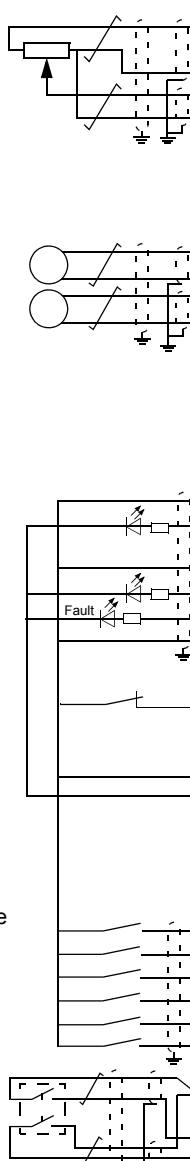

XPOW External power input		
1	+24VI	24 V DC, 2 A
2	GND	

XAI Reference voltage and analog inputs		
1	+VREF	10 V DC, R_i 1...10 kohm
2	-VREF	-10 V DC, R_i 1...10 kohm
3	AGND	Ground
4	AI1+	Speed reference 0(2)...10 V, R_{in} > 200 kohm ¹⁾
5	AI1-	
6	AI2+	By default not in use. 0(4)...20 mA, R_{in} = 100 ohm ²⁾
7	AI2-	
J1	J1	AI1 current/voltage selection jumper
J2	J2	AI2 current/voltage selection jumper

XAO Analog outputs		
1	AO1	Motor speed rpm 0...20 mA, R_L < 500 ohm
2	AGND	
3	AO2	Motor current 0...20 mA, R_L < 500 ohm
4	AGND	

XD2D Drive-to-drive link		
1	B	
2	A	Drive-to-drive link
3	BGND	
J3	J3	Drive-to-drive link termination switch

XRO1, XRO2, XRO3 Relay outputs		
11	NC	Ready 250 V AC / 30 V DC 2 A
12	COM	
13	NO	
21	NC	Running 250 V AC / 30 V DC 2 A
22	COM	
23	NO	
31	NC	Faulted(-1) 250 V AC / 30 V DC 2 A
32	COM	
33	NO	

XD24 Digital interlock		
1	DIIL	Run enable
2	+24VD	+24 V DC 200 mA ³⁾
3	DICOM	Digital input ground
4	+24VD	+24 V DC 200 mA ³⁾
5	DIOGND	Digital input/output ground
J6	Ground selection switch	

XDIO Digital input/outputs		
1	DIO1	Output: Ready
2	DIO2	Output: Running

XDI Digital inputs		
1	DI1	Stop (0) / Start (1)
2	DI2	Forward (0) / Reverse (1)
3	DI3	Reset
4	DI4	Acceleration & deceleration select ⁴⁾
5	DI5	Constant speed 1 (1 = On)
6	DI6	By default not in use.

XSTO Safe torque off		
1	OUT1	Safe torque off. Both circuits must be closed for the drive to start.
2	SGND	
3	IN1	
4	IN2	

See the next page for the notes.











Notes:

- 1) Current [0(4)...20 mA, $R_{in} = 100 \text{ ohm}$] or voltage [0(2)...10 V, $R_{in} > 200 \text{ kohm}$] input selected with jumper J1. Change of setting requires reboot of control unit.
- 2) Current [0(4)...20 mA, $R_{in} = 100 \text{ ohm}$] or voltage [0(2)...10 V, $R_{in} > 200 \text{ kohm}$] input selected with jumper J2. Change of setting requires reboot of control unit.
- 3) Total load capacity of these outputs is 4.8 W (200 mA / 24 V) minus the power taken by DIO1 and DIO2.
- 4) 0 = open, 1 = closed

D14	Ramp times according to
0	Parameters 23.12 and 23.13
1	Parameters 23.14 and 23.15

Further information on the usage of the connectors and jumpers is given in the sections below. See also section [Control unit \(ZCU-12\) connection data](#) on page 185.

Jumpers and switches

Jumper/Switch	Description	Positions
J1 (A11)	Determines whether analog input AI1 is used as a current or voltage input.	 Current (I)
		 Voltage (U)
J2 (A12)	Determines whether analog input AI2 is used as a current or voltage input.	 Current (I)
		 Voltage (U)
J3	Drive-to-drive link termination. Must be set to terminated position when the drive is the last unit on the link.	 Bus is terminated.
		 Bus is not terminated.
J6	Common digital input ground selection switch. Determines whether DICOM is separated from DIOGND (ie, common reference for digital inputs floats). See Ground isolation diagram on page 188.	 DICOM and DIOGND connected (default).
		 DICOM and DIOGND separated.



AI1 and AI2 as Pt100, Pt1000, PTC and KTY84 sensor inputs (XAI, XAO)

Three Pt100, Pt1000 and PTC sensors or one KTY84 sensor for motor temperature measurement can be connected between an analog input and output as shown below. Leave the other end of the shield unconnected or ground it indirectly via a few nanofarads high-frequency capacitor, for example, 3.3 nF / 630 V. The shield can also be grounded directly at both ends if they are in the same ground line with no significant voltage drop between the end points.

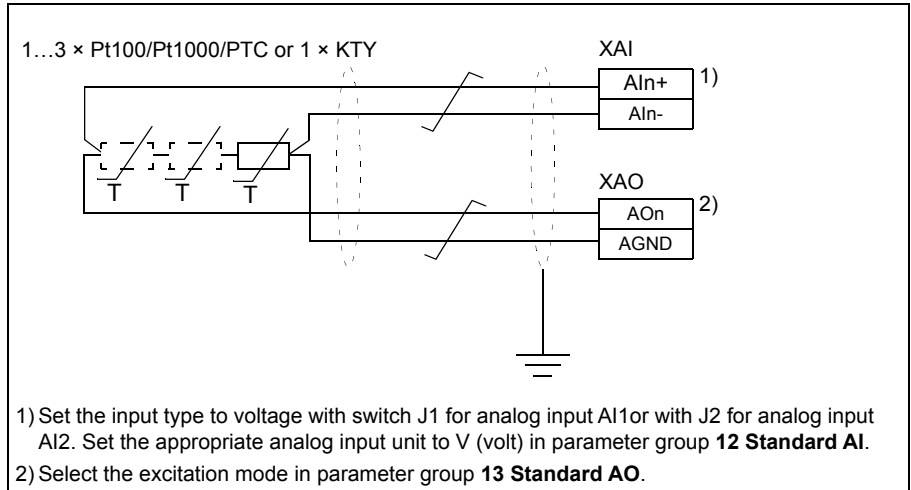

WARNING! As the inputs pictured above are not insulated according to IEC 60664, the connection of the motor temperature sensor requires double or reinforced insulation between motor live parts and the sensor. If the assembly does not fulfill the requirement, the control unit I/O terminals must be protected against contact and must not be connected to other equipment or the temperature sensor must be isolated from the I/O terminals.

External power supply for the control unit (XPOW)

External +24 V (2 A) power supply for the control unit can be connected to terminal block XPOW. Using an external supply is recommended if

- the control unit needs to be kept operational during input power breaks, for example, due to continuous fieldbus communication
- immediate restart is needed after power breaks (that is, no control unit power up delay is allowed).

Drive-to-drive link (XD2D)

The drive-to-drive link is a daisy-chained RS-485 transmission line that can be used for

- basic master/follower communication with one master drive and multiple followers
- fieldbus control through the embedded fieldbus interface (EFB), and
- drive-to-drive (D2D) communication implemented by application programming.

See the firmware manual of the drive for the related parameter settings.

Set termination activation jumper J3 (see section [Jumpers and switches](#) on page 98) next to this terminal block to the ON position on the drives at the ends of the drive-to-drive link. On intermediate drives, set the jumper to the OFF position.

Use shielded twisted-pair cable with a twisted pair for data and a wire or another pair for signal ground (nominal impedance 100 to 165 ohm, for example Belden 9842) for the wiring. For best immunity, ABB recommends high quality cable. Keep the cable as short as possible. Avoid unnecessary loops and running the cable near power cables (such as motor cables).

The following diagram shows the wiring of the drive-to-drive link.

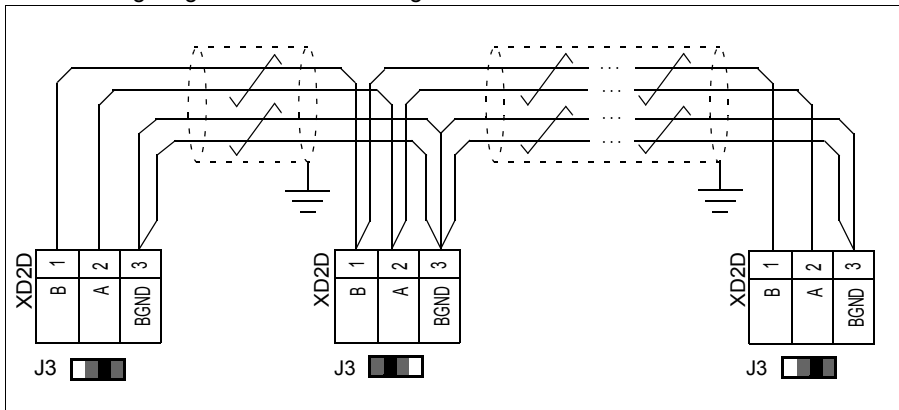

DIIL input (XD24:1)

The DIIL input can be selected as the source of, for example, an emergency stop command or an external event. See the firmware manual for more information.

DI6 (XDI:6) as PTC sensor input

A PTC sensor can be connected to this input for motor temperature measurement as follows. The sensor resistance must not exceed the threshold resistance of the digital input at the motor normal operating temperature. Do not connect both ends of the cable shield directly to ground. Leave the other end of the shield unconnected or ground it indirectly via a few nanofarads high-frequency capacitor, for example, 3.3 nF / 630 V. The shield can also be grounded directly at both ends if they are in the same ground line with no significant voltage drop between the end points. See the firmware manual for parameter settings.

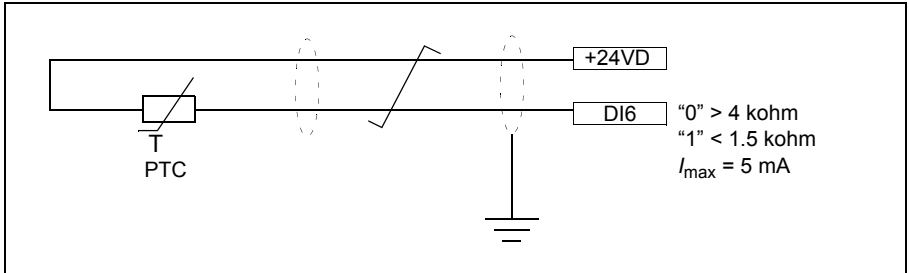

WARNING! As the inputs pictured above are not insulated according to IEC 60664, the connection of the motor temperature sensor requires double or reinforced insulation between motor live parts and the sensor. If the assembly does not fulfill the requirement, the control unit I/O terminals must be protected against contact and must not be connected to other equipment or the temperature sensor must be isolated from the I/O terminals.

Safe torque off (XSTO)

For the drive to start, both connections (OUT1 to IN1 and IN2) must be closed. By default, the terminal block has jumpers to close the circuit. Remove the jumpers before connecting an external Safe torque off circuitry to the drive. See chapter [The Safe torque off function](#) on page 213.

Safety functions module connection (X12)

See section [Implementing the safety functions provided with the FSO safety functions module \(options +Q972 and +Q973\)](#) on page 68, and *FSO-12 safety functions module user's manual* (3AXD50000015612 [English]) or *FSO-21 safety functions module user's manual* (3AXD50000015614 [English]).

Control cable connection procedure (IEC)



WARNING! Obey the instructions in chapter [Safety instructions](#) on page 13. If you ignore them, injury or death, or damage to the equipment can occur.

1. Stop the drive and do the steps in section [Precautions before electrical work](#) on page 16 before you start the work.
2. Remove the front cover(s) if not already removed. See page 86.
3. For frame R3, pull the control panel holder up.

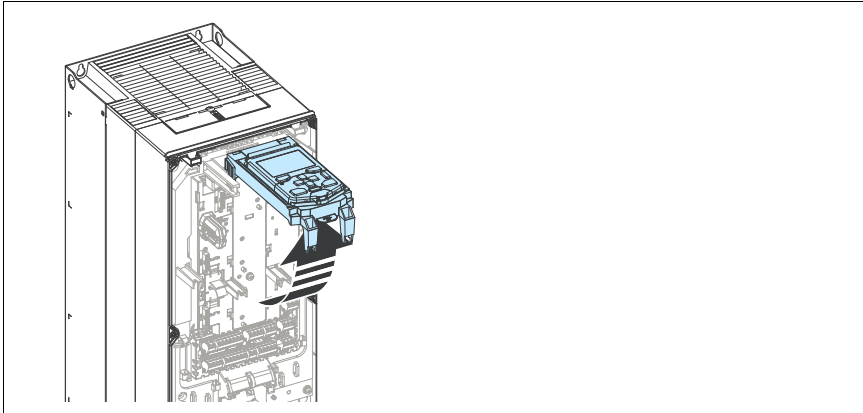

4. Cut an adequate hole into the rubber grommet and slide the grommet onto the cable. Slide the cable through a hole in the bottom plate and attach the grommet to the hole.
5. Route the cable as shown in the figures below.
6. Ground the outer shield of the cable 360 degrees under the grounding clamp at the cable entry. Keep the cable unstripped as close to the terminals of the control unit as possible. Secure the cables inside the drive mechanically.
7. Frame R3: Leave the pair cable shields and grounding wires unconnected at the drive end, and ground them at the other cable end. Cut any unconnected wires at the drive end. Frame R6 and R8: Ground the pair-cable shields and grounding wire under the clamp below the control unit.
8. Connect the conductors to the appropriate terminals of the control unit (see page 97) and tighten to 0.5...0.6 N·m.

Note:

- Leave the other ends of the control cable shields unconnected or ground them indirectly via a high-frequency capacitor with a few nanofarads, eg. 3.3 nF / 630 V. The shield can also be grounded directly at both ends if they are *in the same ground line* with no significant voltage drop between the end points.
- Keep any signal wire pairs twisted as close to the terminals as possible. Twisting the wire with its return wire reduces disturbances caused by inductive coupling.



R3

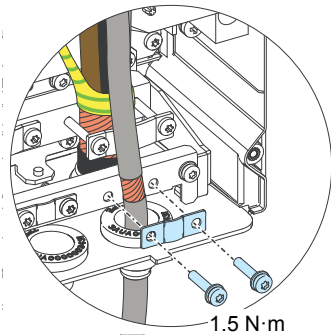
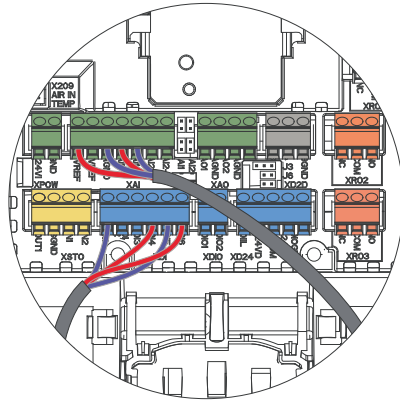
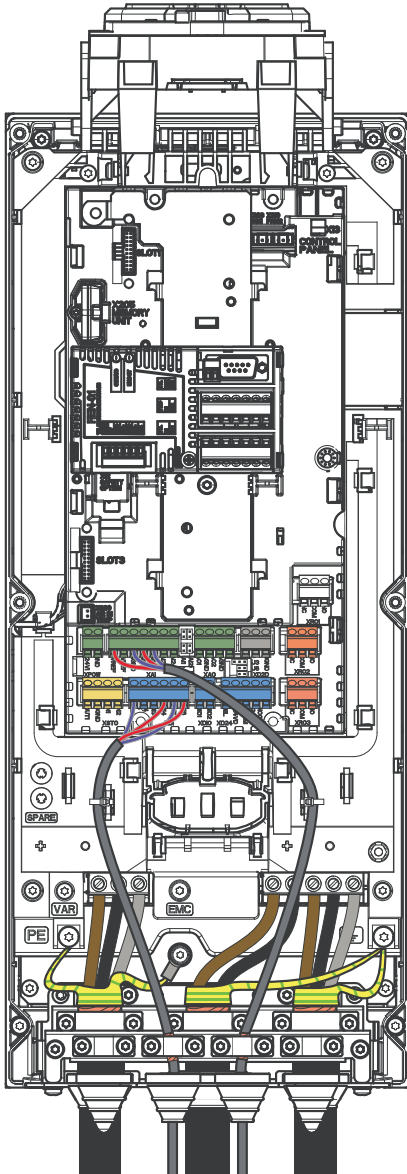

1.5 N·m



R6

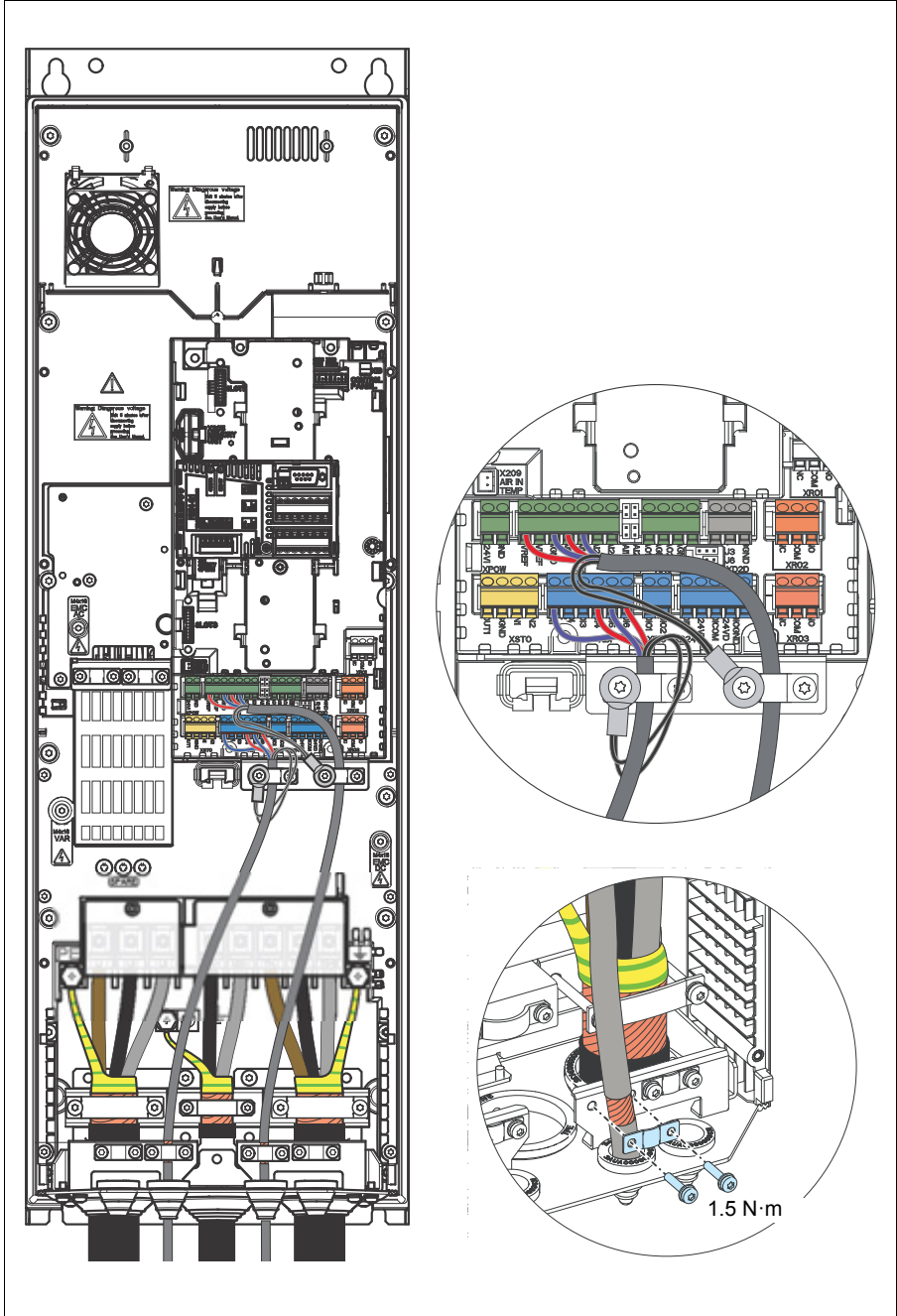

R8

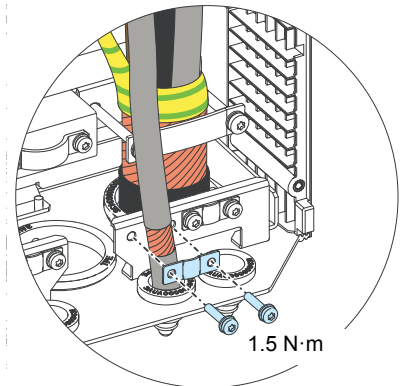
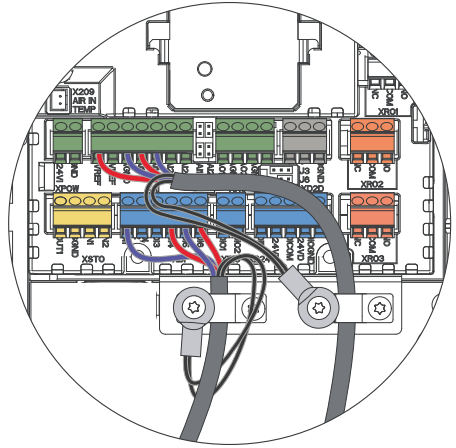
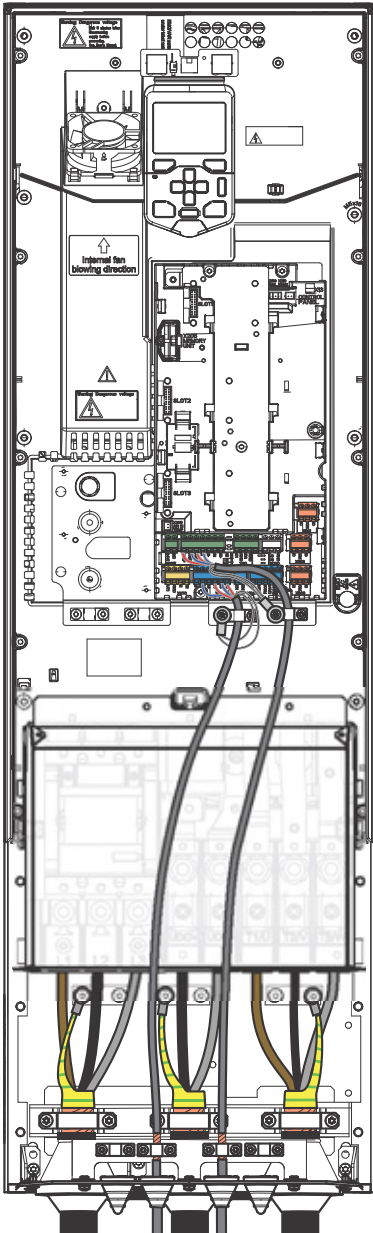

Installing option modules

■ Mechanical installation of option modules

See section [Overview of power and control connections](#) page 33 for the available slots for each module. Install the option modules as follows:



WARNING! Obey the instructions in chapter [Safety instructions](#) on page 13. If you ignore them, physical injury or death, or damage to the equipment can occur.

1. Stop the drive and disconnect it from the power line. Wait for 5 minutes and then make sure by measuring that there is no voltage. See section [Precautions before electrical work](#) on page 16 before you start the work.
2. Remove the front cover(s) if not already removed (see page 86).
3. For frame R3, pull the control panel holder up.

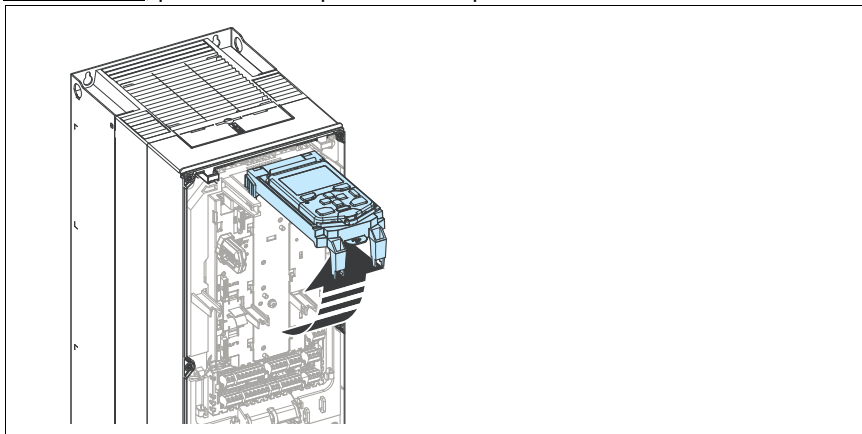

4. Insert the module carefully into its position on the control unit.
-

5. Tighten the mounting screw torque of 0.8 N·m. **Note:** The screw tightens the connections and grounds the module. It is essential for fulfilling the EMC requirements and for proper operation of the module.

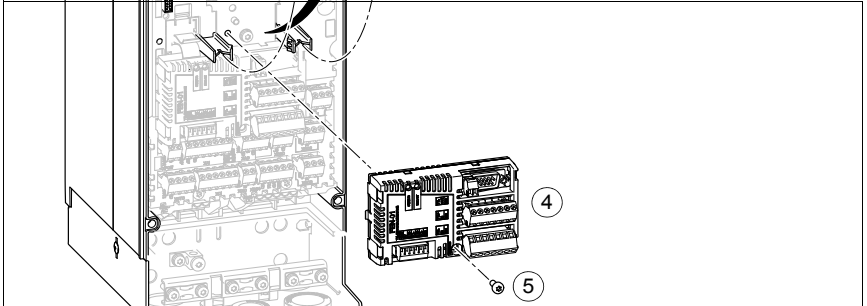

■ Wiring option modules

See the appropriate optional module manual for specific installation and wiring instructions. See section [Control cable connection procedure \(IEC\)](#) on page 101 for the routing of the cables.



■ Installation of safety functions modules

The safety functions module can be mounted onto Slot 2 on the control unit or, in frames R6 and R8, also next to the control unit.

Installation procedure into Slot 2



WARNING! Obey the instructions in chapter [Safety instructions](#) on page 13. If you ignore them, physical injury or death, or damage to the equipment can occur.

1. Stop the drive and disconnect it from the power line. Wait for 5 minutes and then make sure by measuring that there is no voltage. See section [Precautions before electrical work](#) on page 16 before you start the work.
2. Remove the front cover (see the section [Connection procedure](#) on page 86).
3. For frame R3: Pull the control panel stand up.
4. Insert the module carefully into its position on the control unit.
5. Attach the module with four screws.
6. Tighten the grounding screw of the electronics to 0.8 N·m. **Note:** The grounding screw (a) is essential for fulfilling the EMC requirements and for proper operation of the module.
7. Connect the flat cable to connector X110 on the module and to connector X12 on the drive control unit.
8. Connect the Safe torque off (STO) cable to connector X111 on the module and to connector XSTO on the drive module control unit as shown in section [Wiring](#) on page 214.
9. Connect the external +24 V power supply cable to connector X112.
10. Connect the other wires as shown in *FSO-12 safety functions module user's manual* (3AXD50000015612 [English]) or in *FSO-21 safety functions module user's manual* (3AXD50000015614 [English]).



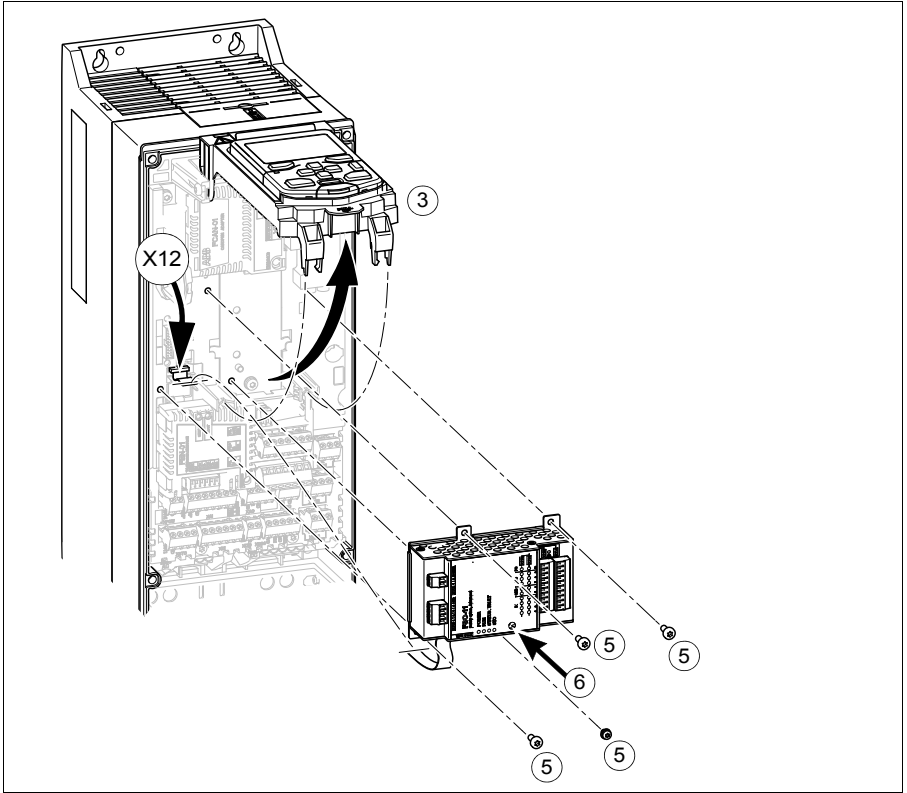

Installation next to the control unit on frames R6 and R8



WARNING! Obey the instructions in chapter [Safety instructions](#) on page 13. If you ignore them, physical injury or death, or damage to the equipment can occur.

1. Stop the drive and disconnect it from the power line. Wait for 5 minutes and then make sure by measuring that there is no voltage. See section [Precautions before electrical work](#) on page 16 before you start the work.
2. Remove the front cover (see page 86.).
3. Insert the module carefully into its position.
4. Attach the module with four screws.
5. Tighten the grounding screw of the electronics to 0.8 N·m. **Note:** Correct installation of the grounding screw (a) is essential for fulfilling the EMC requirements and for proper operation of the module.
6. Connect the flat cable to connector X110 on the module and to connector X12 on the drive control unit.
7. Connect the Safe torque off (STO) cable to connector X111 on the module and to connector XSTO on the drive module control unit as shown in section [Wiring](#) on page 214.
8. Connect the external +24 V power supply cable to connector X112.
9. Connect the other wires as shown in *FSO-12 safety functions module user's manual* (3AXD50000015612 [English]) or in *FSO-21 safety functions module user's manual* (3AXD50000015614 [English]).



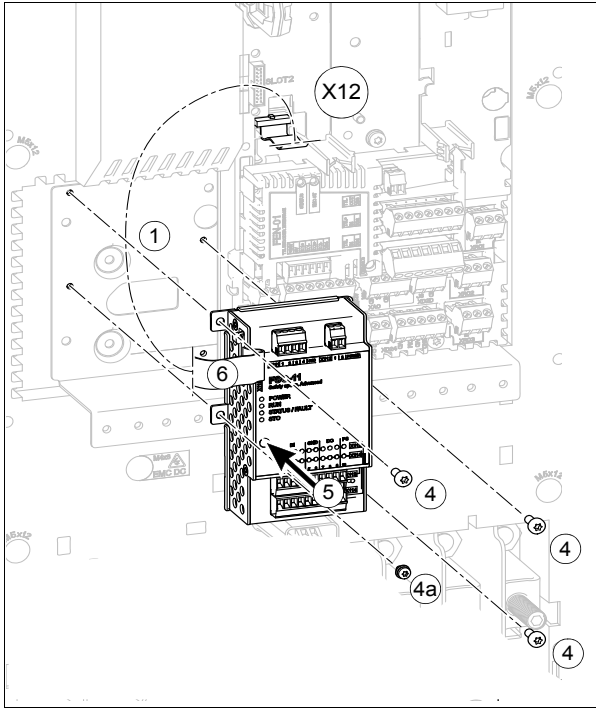

Reinstalling cover(s)

After installation, reinstall the covers.

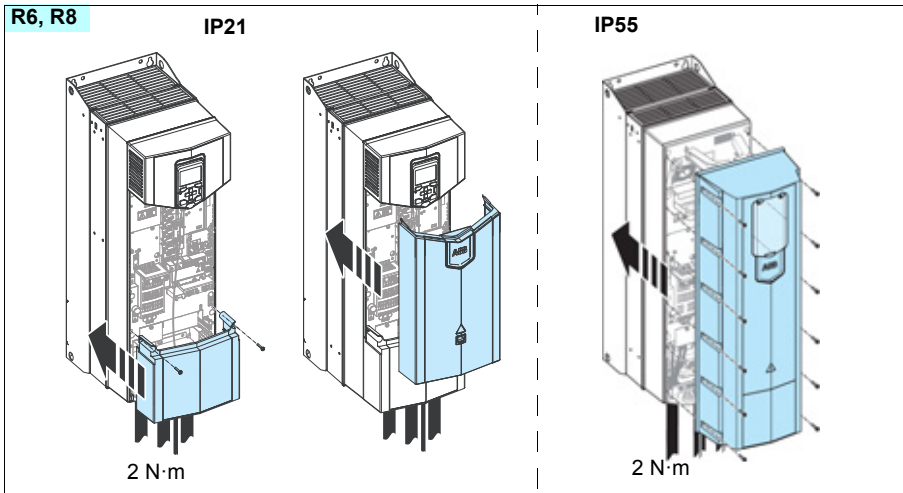
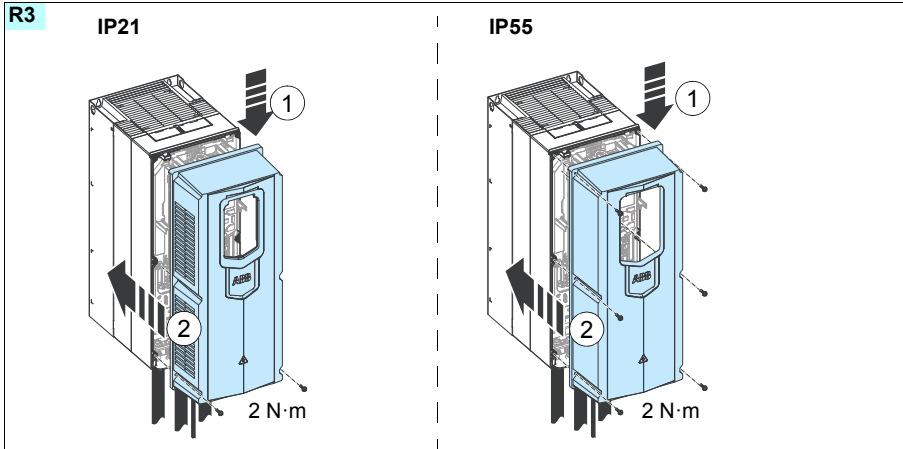

Connecting a PC



WARNING! Do not connect the PC directly to the control panel connector of the control unit. It can cause damage.

Connect a PC to the drive with an USB data cable (USB Type A <-> USB Type Mini-B) as follows:

1. Lift the USB connector cover from bottom upwards.
2. Insert the USB cable Mini-B plug in the control panel USB connector.
3. Insert the USB cable A-plug in the USB connector of the PC. -> The panel displays: USB connected.

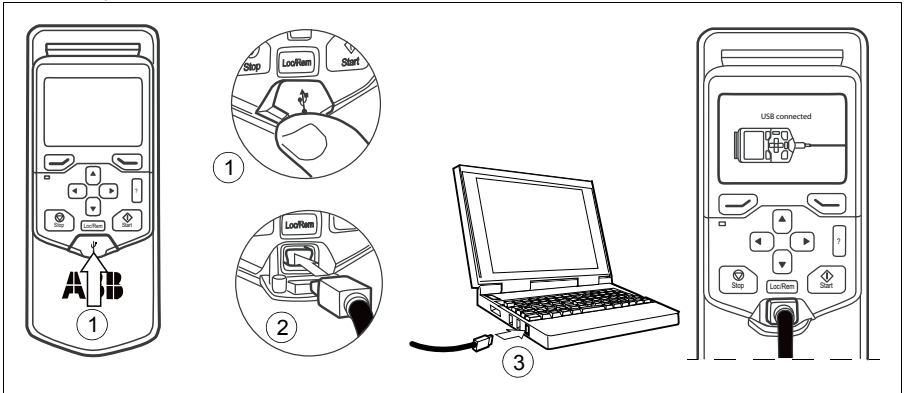

Controlling several drives through the panel bus

One control panel (or PC) can be used to control several drives by constructing a panel bus.

Note: If the panel platform does not have two connectors for the panel cable, you need an additional FDPI-02 module for chaining the panel bus. See *FDPI-02 diagnostics and panel interface user's manual* (3AUA0000113618 [English]).

1. Connect the panel to one drive using an Ethernet (eg. CAT5E) cable.

Note for IP55 (UL Type 12) drives: Remove the front cover and put the cables through the control cable lead-throughs.

- Use **Menu – Settings – Edit texts – Drive** to give a descriptive name to the drive.
- Use parameter **49.01** to assign the drive with a unique node ID number.
- Set other parameters in group **49** if necessary.
- Use parameter **49.06** to validate any changes.

Repeat the above for each drive.

2. With the panel connected to one drive, link the drives together using Ethernet cables. (Each panel platform has two connectors.)
3. In the last drive, switch bus termination on. With a panel platform, move the terminating switch into the outer position. Termination should be off on all other units.
4. On the control panel, switch on the panel bus functionality (**Options – Select drive – Panel bus**). The unit to be controlled can now be selected from the list under **Options – Select drive**.
5. If a PC is connected to the control panel, the drives on the panel bus are automatically displayed in the Drive composer tool.
6. For IP55 (UL Type 12) drives, Install the front cover.



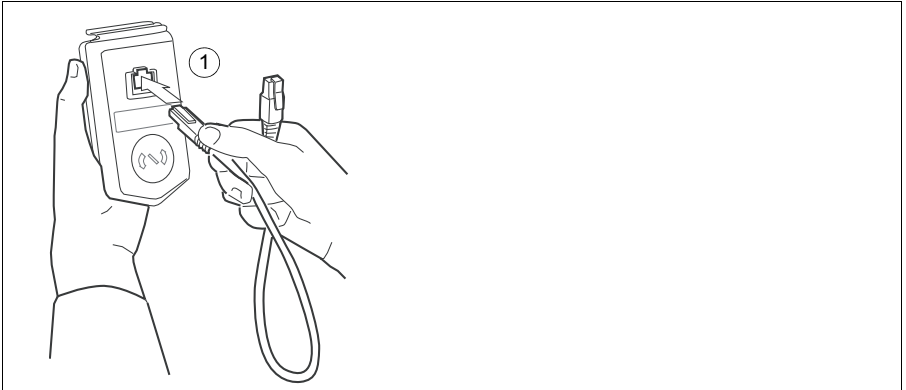

IP21

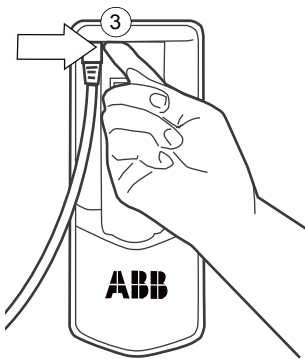
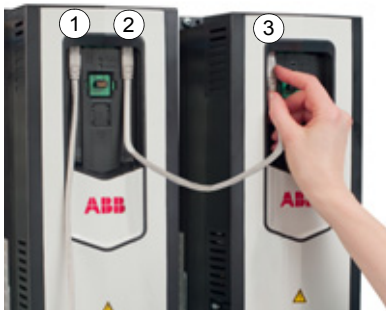

IP55

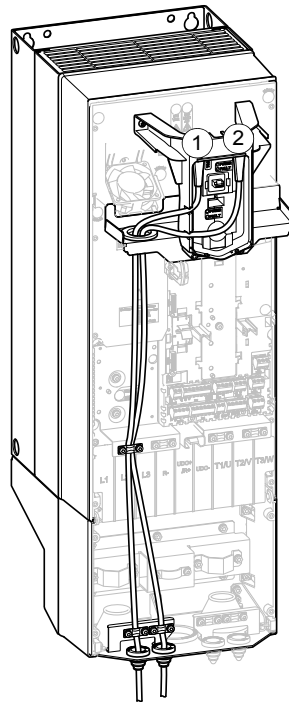



7

Electrical installation – USA

Contents of this chapter

The chapter describes how to check the insulation of the assembly and the compatibility with grounding systems. It then shows how to connect the power and control cables, install optional modules and connect a PC.

Warnings

 **WARNING!** Obey the instructions in chapter [Safety instructions](#) on page 13. If you ignore them, injury or death, or damage to the equipment can occur.

Make sure that the drive is disconnected from the input power during installation. If you need to disconnect the drive, wait for 5 minutes after disconnecting the input power before you start the work.

Required tools

- wire stripper
- screwdriver and/or wrench with a set of suitable bits



Checking the insulation of the assembly

■ Drive

Do not make any voltage tolerance or insulation resistance tests on any part of the drive as testing can damage the drive. Every drive has been tested for insulation between the main circuit and the chassis at the factory. Also, there are voltage-limiting circuits inside the drive which cut down the testing voltage automatically.

Input power cable

Check the insulation of the input cable according to local regulations before connecting it to the drive.

Motor and motor cable

Check the insulation of the motor and motor cable as follows:

1. Stop the drive and do the steps in section *Precautions before electrical work* on page 16 before you start the work.
2. Check that the motor cable is disconnected from the drive output terminals T1/U, T2/V and T3/W.
3. Measure the insulation resistance between the phase conductors and between each phase conductor and the Protective Earth conductor. Use a measuring voltage of 1000 V DC. The insulation resistance of a motor must exceed 100 Mohm (reference value at 25 °C or 77 °F). For the insulation resistance of other motors, please consult the manufacturer's instructions.

Note: Moisture inside the motor casing will reduce the insulation resistance. If moisture is suspected, dry the motor and repeat the measurement.

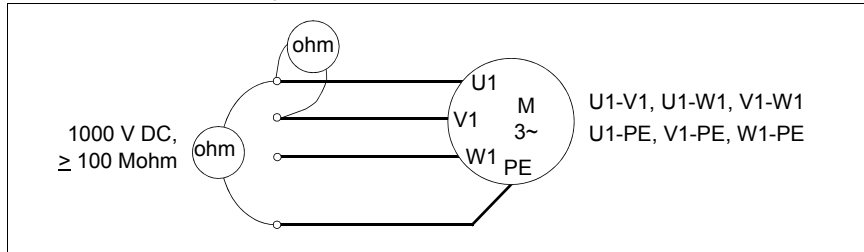

Brake resistor assembly

Check the insulation of the brake resistor assembly (if present) as follows:

1. Stop the drive and do the steps in section *Precautions before electrical work* on page 16 before you start the work.
2. Check that the resistor cable is connected to the resistor, and disconnected from the brake chopper output terminals.
3. At the brake chopper end, connect the R+ and R- conductors of the resistor cable together. Measure the insulation resistance between the combined conductors



and the PE conductor by using a measuring voltage of 1 kV DC. The insulation resistance must be higher than 1 Mohm.

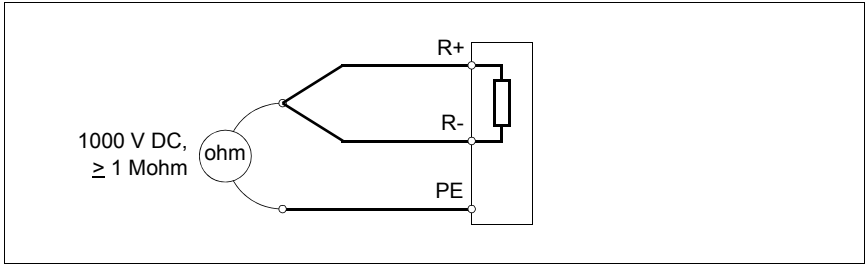

Checking the compatibility with IT (ungrounded), corner-grounded and midpoint-grounded delta systems, and TT systems

See section [Checking the compatibility with IT \(ungrounded\), corner-grounded delta, midpoint-grounded delta, and TT systems](#) on page 78.



Connecting the power cables

Connection diagram

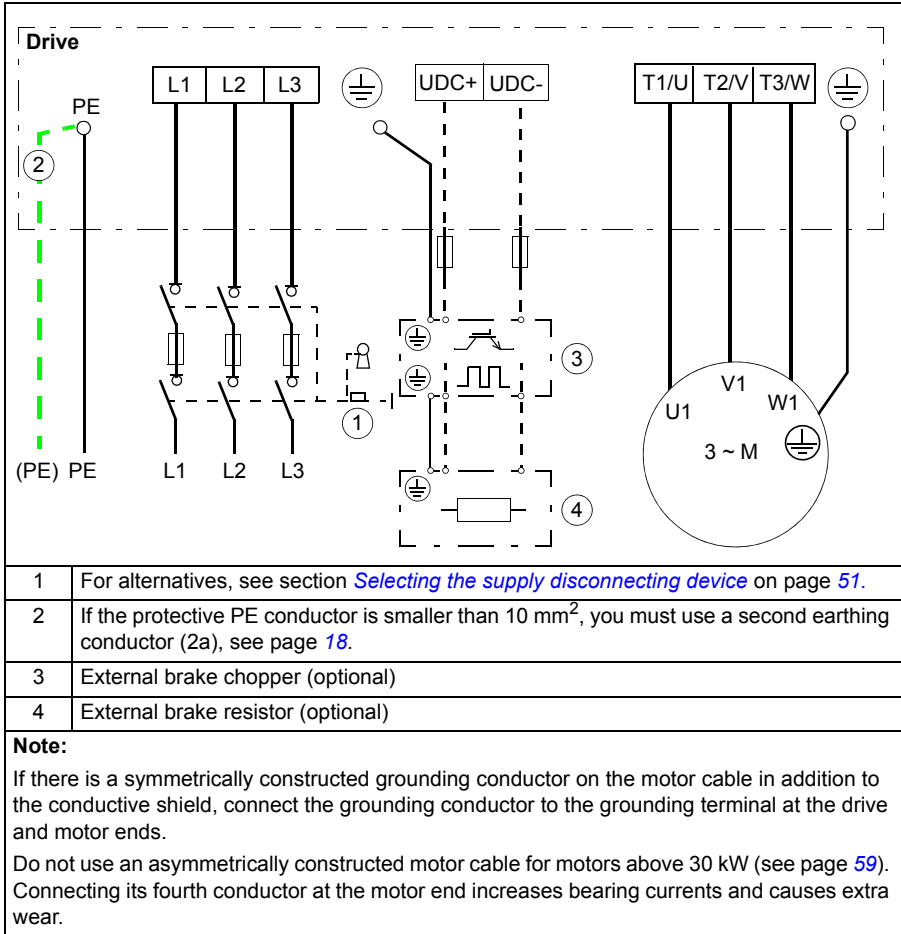

■ Connection procedure

The procedure of connecting the power cables to the standard drive is described below.

1. For frame R3: Remove the front cover:

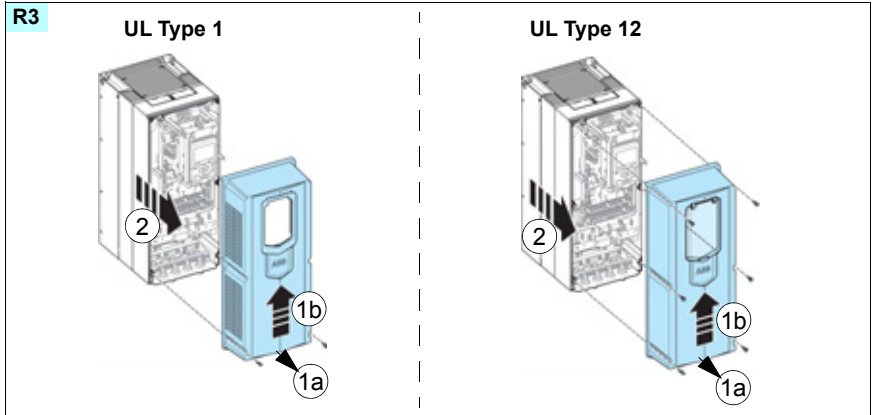

For frame R6 and R8 (UL Type 1): Remove the covers as follows:

- To remove the middle front cover, loosen the retaining screw with a screwdriver. Remove the cover.
- Remove the lower front cover

For frame R6 and R8 (UL Type 12): Remove the covers as follows:

- Loosen the screws that attach the front cover to the frame.
- Remove the cover.



R6, R8

UL Type 1

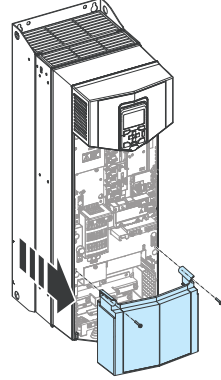
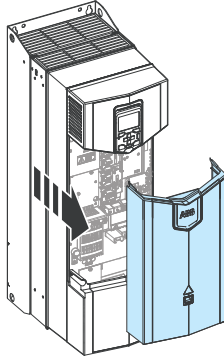
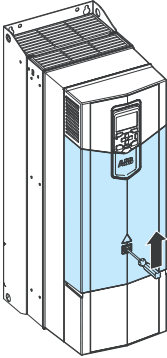

UL Type 12

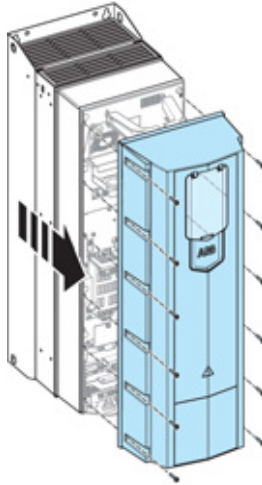

WARNING! Make sure you have disconnected the EMC filter and/or ground-to-phase varistor when necessary. See [Checking the compatibility with IT \(ungrounded\), corner-grounded delta, midpoint-grounded delta, and TT systems](#) page 78.

2. Attach the residual voltage warning sticker in the local language.

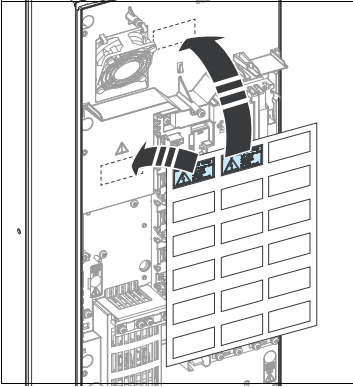

3. For frames R6 and R8: Remove the shroud on the power cable terminals,

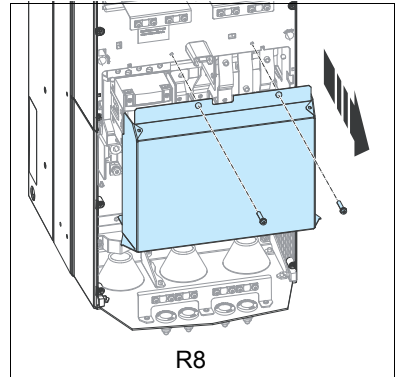
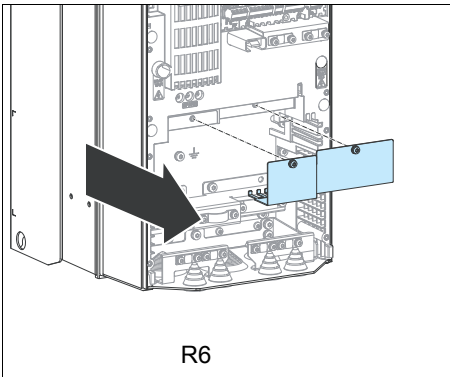

4. For frame R8: For easier installation, you can remove the side plates.

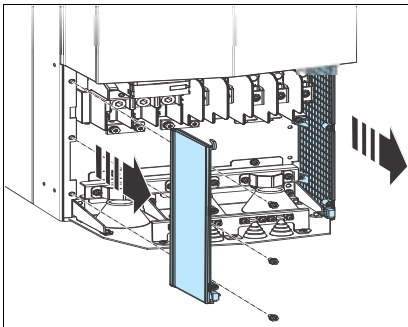

5. Remove the rubber grommets of the cables to be installed from the cable entry plate.



6. Attach the cable conduits to the bottom plate holes.

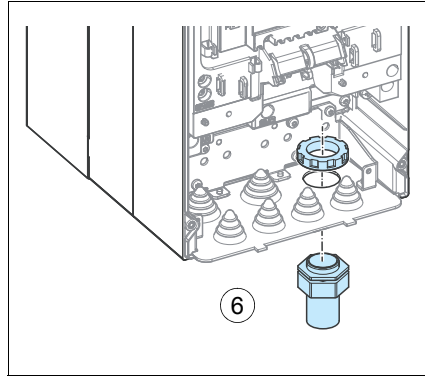
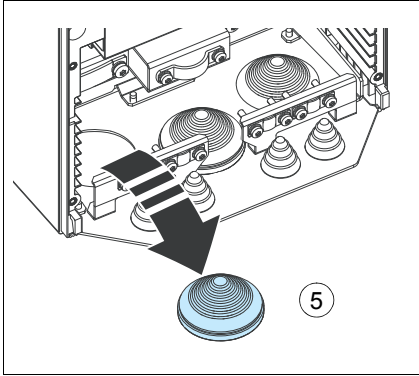

7. Remove the cable shelves.
8. Reinstall the four screw plugs to avoid moisture exchange through the empty holes!

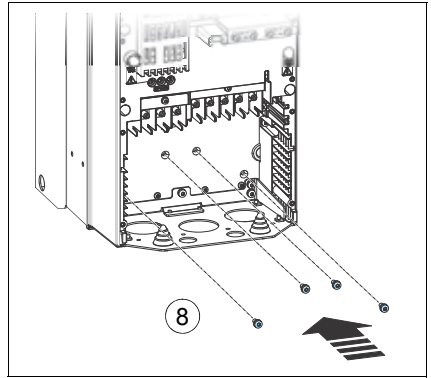
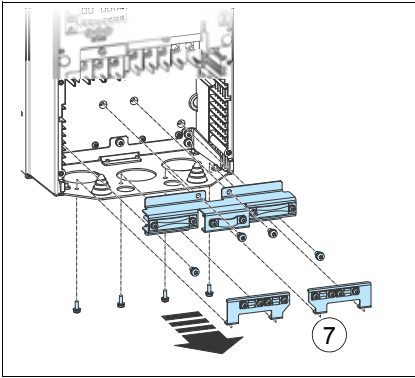

9. Strip the cable ends. (Note the extra length of the grounding conductors.) Slide the cables through the connectors.

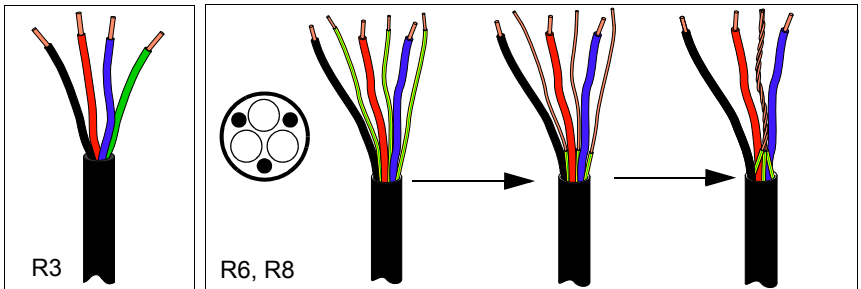

10. Connect the cables:

- Connect the grounding conductors to the grounding terminals.
- Connect the phase conductors of the motor cable to the T1/U, T2/V and T3/W terminals and the phase conductors of the input cable to the T1, T2 and T3 terminals.



- If DC cables are present, cut off one phase conductor and connect the remaining conductors to the UDC+ and UDC- terminals.

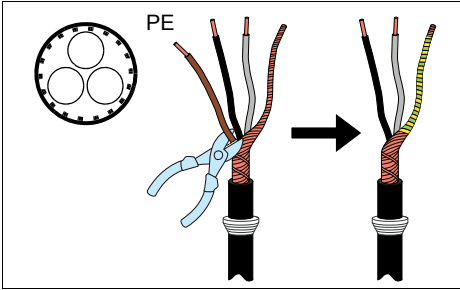

- Tighten the screws to the torque given below in the installation drawing.

R3

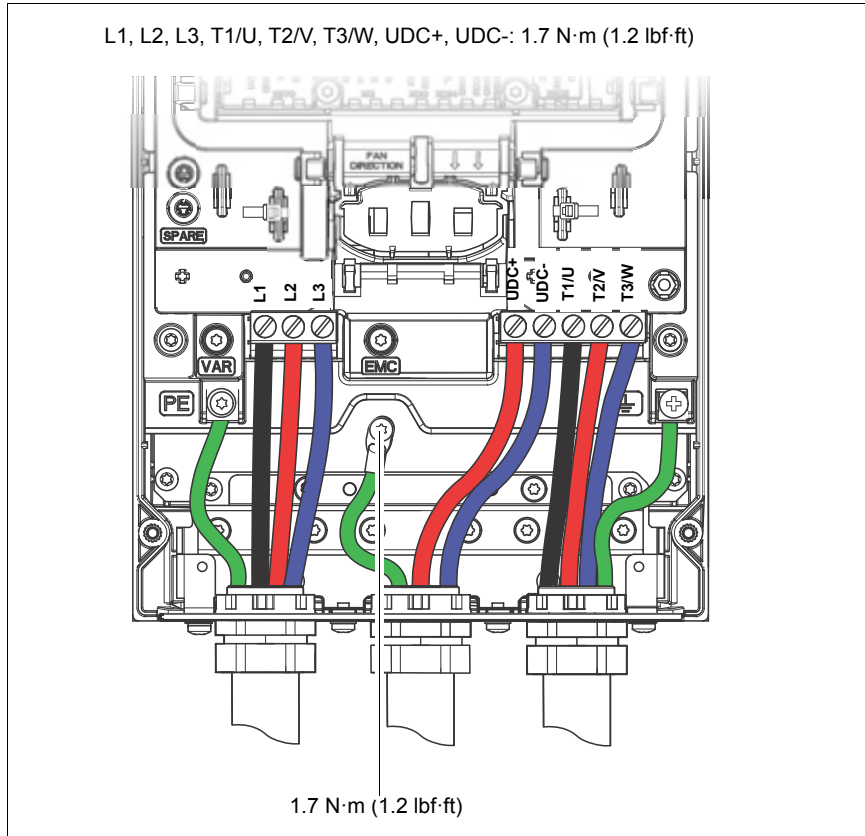

R6

L1, L2, L3, T1/U, T2/V, T3/W, UDC+, UDC-: 5.6 N·m (4.1 lbf·ft)

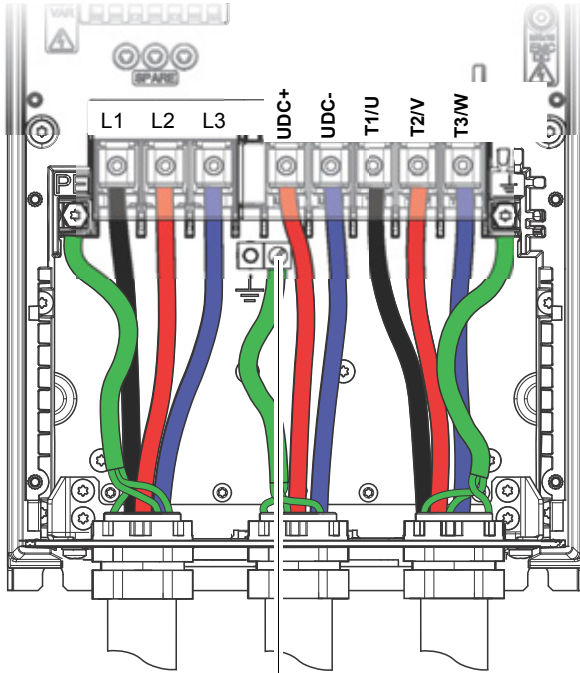

2.9 N·m (2.1 lbf·ft)



R8

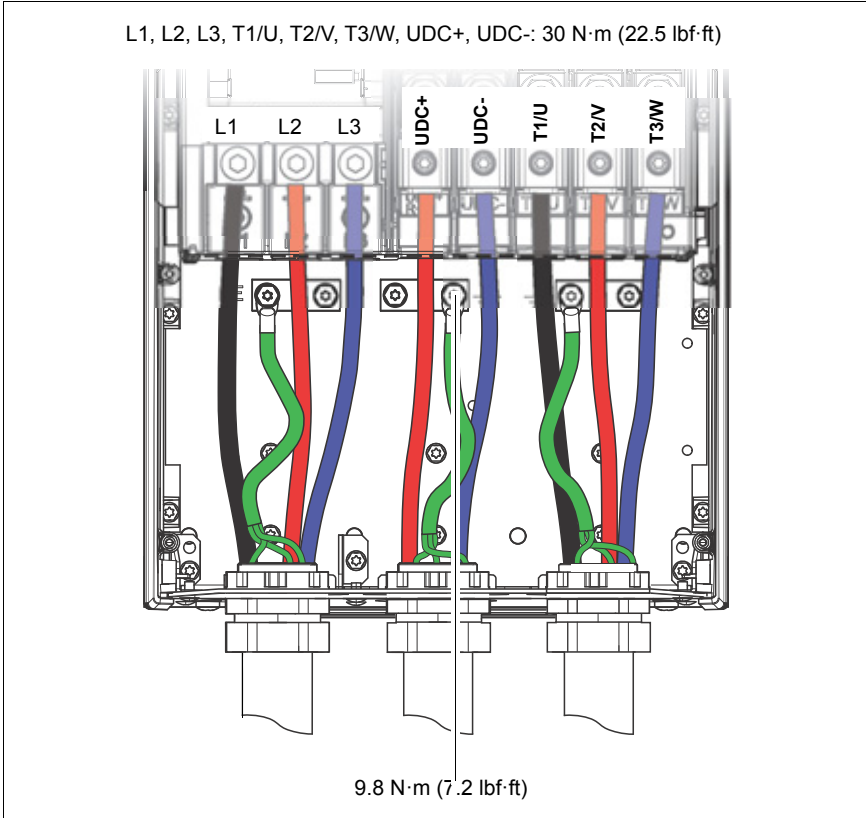

Note 1 for frame R8: Install the side plates if removed.

Note 2 for frame R8: The motor cable connectors can be detached. For the instructions, see section [R8 motor cable connection if you detach the connectors](#) on page [130](#).



11. For frame R6 types bigger than -040A-x: Cut tabs in the shroud for the installed cables. For frame R8: Knock out holes in the shroud for the input cables.

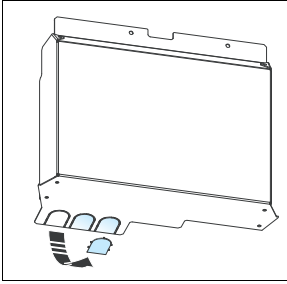

12. Install the shroud onto the power cable connection terminals.

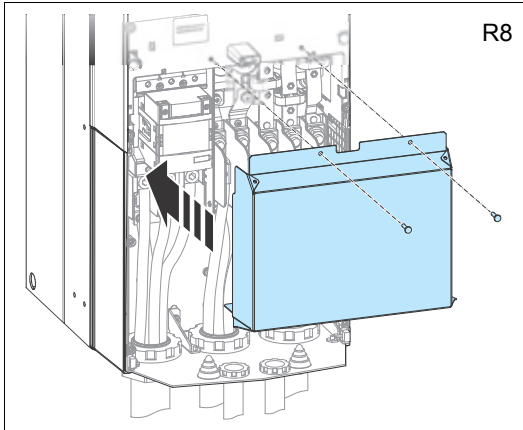
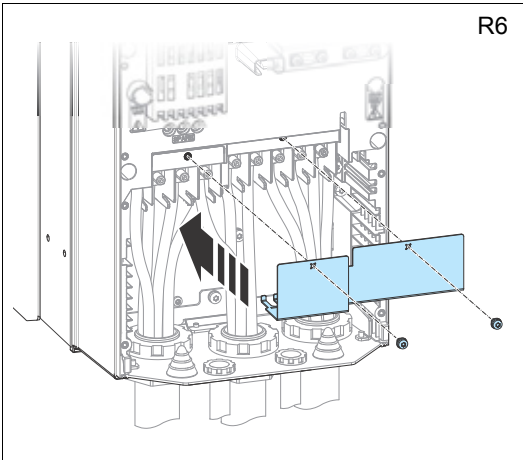

R8 motor cable connection if you detach the connectors

The motor cable connection connectors of frame R8 are detachable. If you detach them, you can connect the motor cables with cable lugs as follows. For UL installations, see also section [UL listed cable lugs and tools](#) on page 182.

Cable lug installation for T1/U, T2/V, T3/W, UDC+ and UDC-:

- Remove the nut that attaches the connector to its terminal post and remove the connector.
- Attach the conductor to the cable lug. Put the cable lug onto the post.
- Tighten the nut to a torque of 30 N·m (22 lbf·ft).

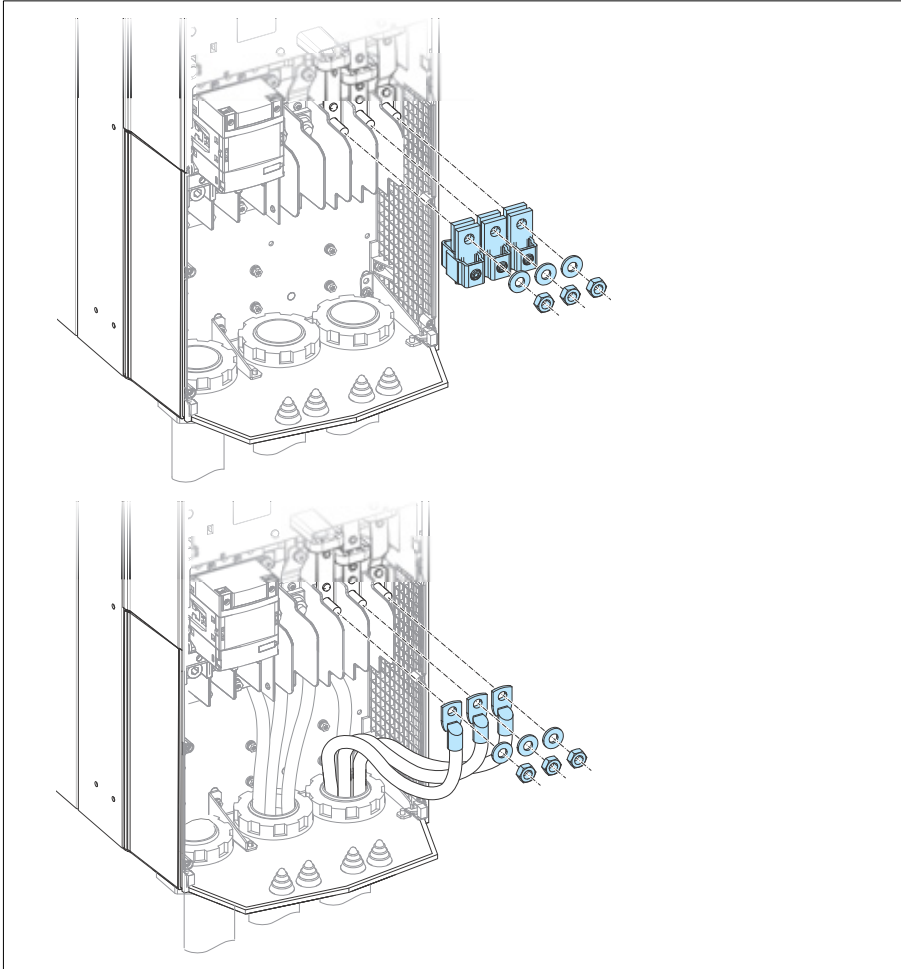

Connecting the control cables

See section [Default I/O connection digram](#) on page [132](#) for the default I/O connections of the drive.

Connect the cables as described under [Control cable connection procedure](#) on page [136](#).



WARNING! Do not connect the +24 V AC cable to the control unit ground when the control unit is powered using an external 24 V AC supply.



Default I/O connection diagram

Wire sizes:
0.5 ... 2.5 mm²
(24...14 AWG)
Tightening
torques: 0.5 N·m
(0.4 lbf·ft) for
both stranded
and solid wiring.

XPOW External power input

1	+24VI	24 V DC, 2 A
2	GND	

XAI Reference voltage and analog inputs

1	+VREF	10 V DC, R_L 1...10 kohm
2	-VREF	-10 V DC, R_L 1...10 kohm
3	AGND	Ground
4	AI1+	Speed reference 0(2)...10 V, $R_{in} > 200$ kohm ¹⁾
5	AI1-	
6	AI2+	By default not in use. 0(4)...20 mA, $R_{in} = 100$ ohm ²⁾
7	AI2-	
J1	J1	AI1 current/voltage selection jumper
J2	J2	AI2 current/voltage selection jumper

XAO Analog outputs

1	AO1	Motor speed rpm 0...20 mA, $R_L < 500$ ohm
2	AGND	
3	AO2	Motor current 0...20 mA, $R_L < 500$ ohm
4	AGND	

XD2D Drive-to-drive link

1	B	Drive-to-drive link
2	A	
3	BGND	
J3	J3	Drive-to-drive link termination switch

XRO1, XRO2, XRO3 Relay outputs

11	NC	Ready 250 V AC / 30 V DC 2 A
12	COM	
13	NO	
21	NC	Running 250 V AC / 30 V DC 2 A
22	COM	
23	NO	
31	NC	Faulted(-1) 250 V AC / 30 V DC 2 A
32	COM	
33	NO	

XD24 Digital interlock

1	DIIL	Run enable
2	+24VD	+24 V DC 200 mA ³⁾
3	DICOM	Digital input ground
4	+24VD	+24 V DC 200 mA ³⁾
5	DIOGND	Digital input/output ground
J6	Ground selection switch	

XDIO Digital input/outputs

1	DIO1	Output: Ready
2	DIO2	Output: Running

XDI Digital inputs

1	DI1	Stop (0) / Start (1)
2	DI2	Forward (0) / Reverse (1)
3	DI3	Reset
4	DI4	Acceleration & deceleration select ⁴⁾
5	DI5	Constant speed 1 (1 = On)
6	DI6	By default not in use.

XSTO Safe torque off

1	OUT1	Safe torque off. Both circuits must be closed for the drive to start.
2	SGND	
3	IN1	
4	IN2	

X12 Safety functions module connection
X13 Control panel connection
X205 Memory unit connection



See the next page for the notes.













Notes:

- 1) Current [0(4)...20 mA, $R_{in} = 100 \text{ ohm}$] or voltage [0(2)...10 V, $R_{in} > 200 \text{ kohm}$] input selected with jumper J1. Change of setting requires reboot of control unit.
- 2) Current [0(4)...20 mA, $R_{in} = 100 \text{ ohm}$] or voltage [0(2)...10 V, $R_{in} > 200 \text{ kohm}$] input selected with jumper J2. Change of setting requires reboot of control unit.
- 3) Total load capacity of these outputs is 4.8 W (200 mA / 24 V) minus the power taken by DIO1 and DIO2.
- 4) 0 = open, 1 = closed

DI4 Ramp times according to	
0	Parameters 23.12 and 23.13
1	Parameters 23.14 and 23.15

Further information on the usage of the connectors and jumpers is given in the sections below. See also section [Control unit \(ZCU-12\) connection data](#) on page 185.

Jumpers and switches

Jumper/ Switch	Description	Positions
J1 (AI1)	Determines whether analog input AI1 is used as a current or voltage input.	 Current (I)
		  
J2 (AI2)	Determines whether analog input AI2 is used as a current or voltage input.	 Current (I)
		  
J3	Drive-to-drive link termination. Must be set to terminated position when the drive is the last unit on the link.	 Bus is terminated.
		 Bus is not terminated.
J6	Common digital input ground selection switch. Determines whether DICOM is separated from DIOGND (ie, common reference for digital inputs floats). See Ground isolation diagram on page 196.	 DICOM and DIOGND connected (default).
		 DICOM and DIOGND separated.



AI1 and AI2 as Pt100, Pt1000, PTC and KTY84 sensor inputs (XAI, XAO)

Three Pt100, Pt1000 and PTC sensors or one KTY84 sensor for motor temperature measurement can be connected between an analog input and output as shown below. Leave the other end of the shield unconnected or ground it indirectly via a few nanofarads high-frequency capacitor, for example, 3.3 nF / 630 V. The shield can also be grounded directly at both ends if they are in the same ground line with no significant voltage drop between the end points.

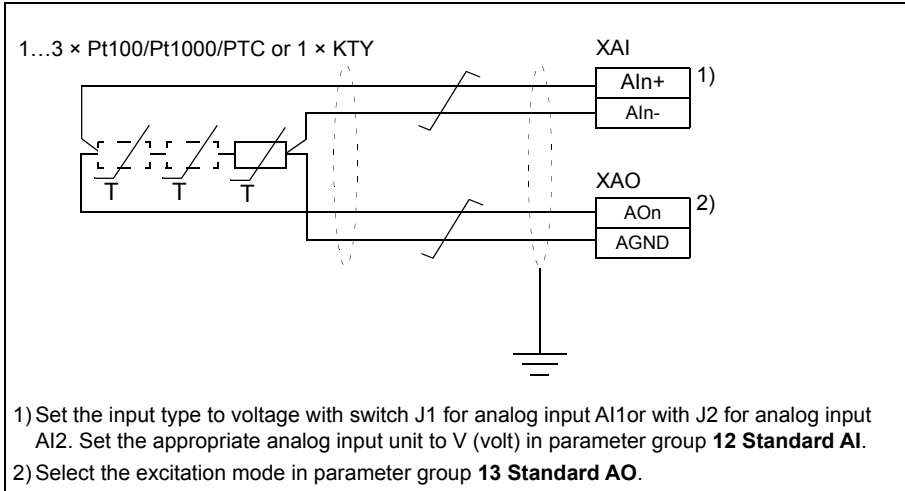

WARNING! As the inputs pictured above are not insulated according to IEC 60664, the connection of the motor temperature sensor requires double or reinforced insulation between motor live parts and the sensor. If the assembly does not fulfill the requirement, the control unit I/O terminals must be protected against contact and must not be connected to other equipment or the temperature sensor must be isolated from the I/O terminals.

External power supply for the control unit (XPOW)

External +24 V (2 A) power supply for the control unit can be connected to terminal block XPOW. Using an external supply is recommended if

- the control unit needs to be kept operational during input power breaks, for example, due to continuous fieldbus communication
- immediate restart is needed after power breaks (that is, no control unit power up delay is allowed).

Drive-to-drive link (XD2D)

The drive-to-drive link is a daisy-chained RS-485 transmission line that can be used for

- basic master/follower communication with one master drive and multiple followers
- fieldbus control through the embedded fieldbus interface (EFB), and
- drive-to-drive (D2D) communication implemented by application programming.

See the firmware manual of the drive for the related parameter settings.

Set termination activation jumper J3 (see section [Jumpers and switches](#) on page 133) next to this terminal block to the ON position on the drives at the ends of the drive-to-drive link. On intermediate drives, set the jumper to the OFF position.

Use shielded twisted-pair cable with a twisted pair for data and a wire or another pair for signal ground (nominal impedance 100 to 165 ohm, for example Belden 9842) for the wiring. For best immunity, ABB recommends high quality cable. Keep the cable as short as possible. Avoid unnecessary loops and running the cable near power cables (such as motor cables).

The following diagram shows the wiring of the drive-to-drive link.

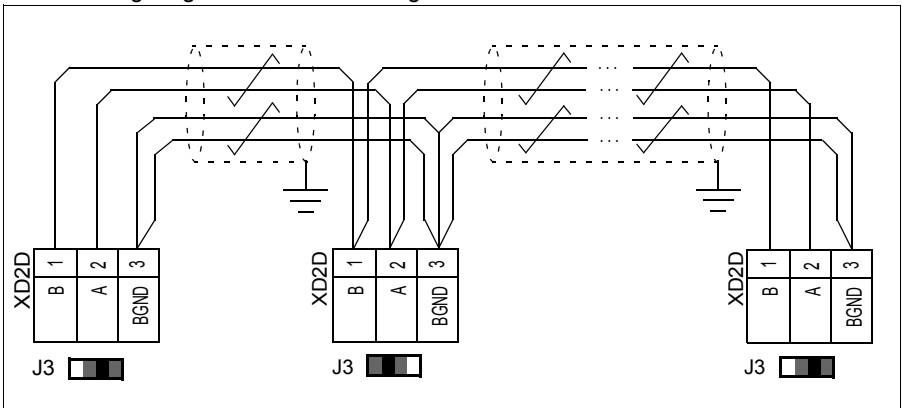

DIIL input (XD24:1)

The DIIL input can be selected as the source of, for example, an emergency stop command or an external event. See the firmware manual for more information.



DI6 (XDI:6) as PTC sensor input

A PTC sensor can be connected to this input for motor temperature measurement as follows. The sensor resistance must not exceed the threshold resistance of the digital input at the motor normal operating temperature. Do not connect both ends of the cable shield directly to ground. Leave the other end of the shield unconnected or ground it indirectly via a few nanofarads high-frequency capacitor, for example, 3.3 nF / 630 V. The shield can also be grounded directly at both ends if they are in the same ground line with no significant voltage drop between the end points. See the firmware manual for parameter settings.

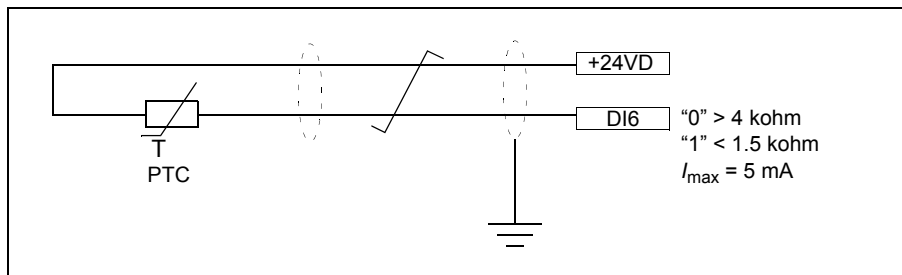

WARNING! As the inputs pictured above are not insulated according to IEC 60664, the connection of the motor temperature sensor requires double or reinforced insulation between motor live parts and the sensor. If the assembly does not fulfill the requirement, the control unit I/O terminals must be protected against contact and must not be connected to other equipment or the temperature sensor must be isolated from the I/O terminals.

Safe torque off (XSTO)

For the drive to start, both connections (OUT1 to IN1 and IN2) must be closed. By default, the terminal block has jumpers to close the circuit. Remove the jumpers before connecting an external Safe torque off circuitry to the drive. See chapter [The Safe torque off function](#) on page 213.

Safety functions module connection (X12)

See section [Implementing the safety functions provided with the FSO safety functions module \(options +Q972 and +Q973\)](#) on page 68, and [FSO-12 safety functions module user's manual](#) (3AXD50000015612 [English]) or [FSO-21 safety functions module user's manual](#) (3AXD50000015614 [English]).

Control cable connection procedure



WARNING! Obey the instructions in chapter [Safety instructions](#) on page 13. If you ignore them, injury or death, or damage to the equipment can occur.

1. Stop the drive and do the steps in section [Precautions before electrical work](#) on page [16](#) before you start the work.
2. Remove the front cover(s) if not already removed. See page [121](#).
3. For frame R3, pull the control panel holder up.

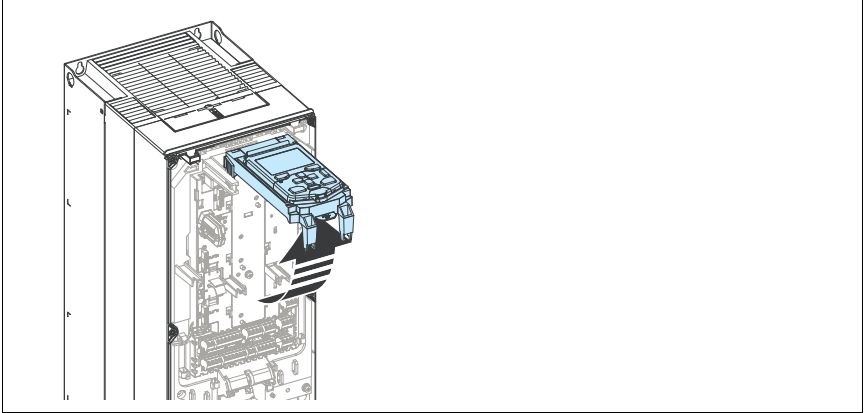

4. Cut an adequate hole into the rubber grommet and slide the grommet onto the cable. Slide the cable through a hole in the bottom plate and attach the grommet to the hole.
5. Route the cable as shown in the figures below.
6. Secure the cables inside the drive mechanically.
7. Frame R3: Leave the pair cable shields and grounding wires unconnected at the drive end, and ground them at the other cable end. Cut any unconnected wires at the drive end. Frame R6 and R8: Ground the pair-cable shields and grounding wire under the clamp below the control unit.
8. Connect the conductors to the appropriate terminals of the control unit (see page [132](#)) and tighten to 0.5...0.6 N·m (0.4 lbf·ft).

Note:

- Leave the other ends of the control cable shields unconnected or ground them indirectly via a high-frequency capacitor with a few nanofarads, eg, 3.3 nF / 630 V. The shield can also be grounded directly at both ends if they are *in the same ground line* with no significant voltage drop between the end points.
- Keep any signal wire pairs twisted as close to the terminals as possible. Twisting the wire with its return wire reduces disturbances caused by inductive coupling.



R3

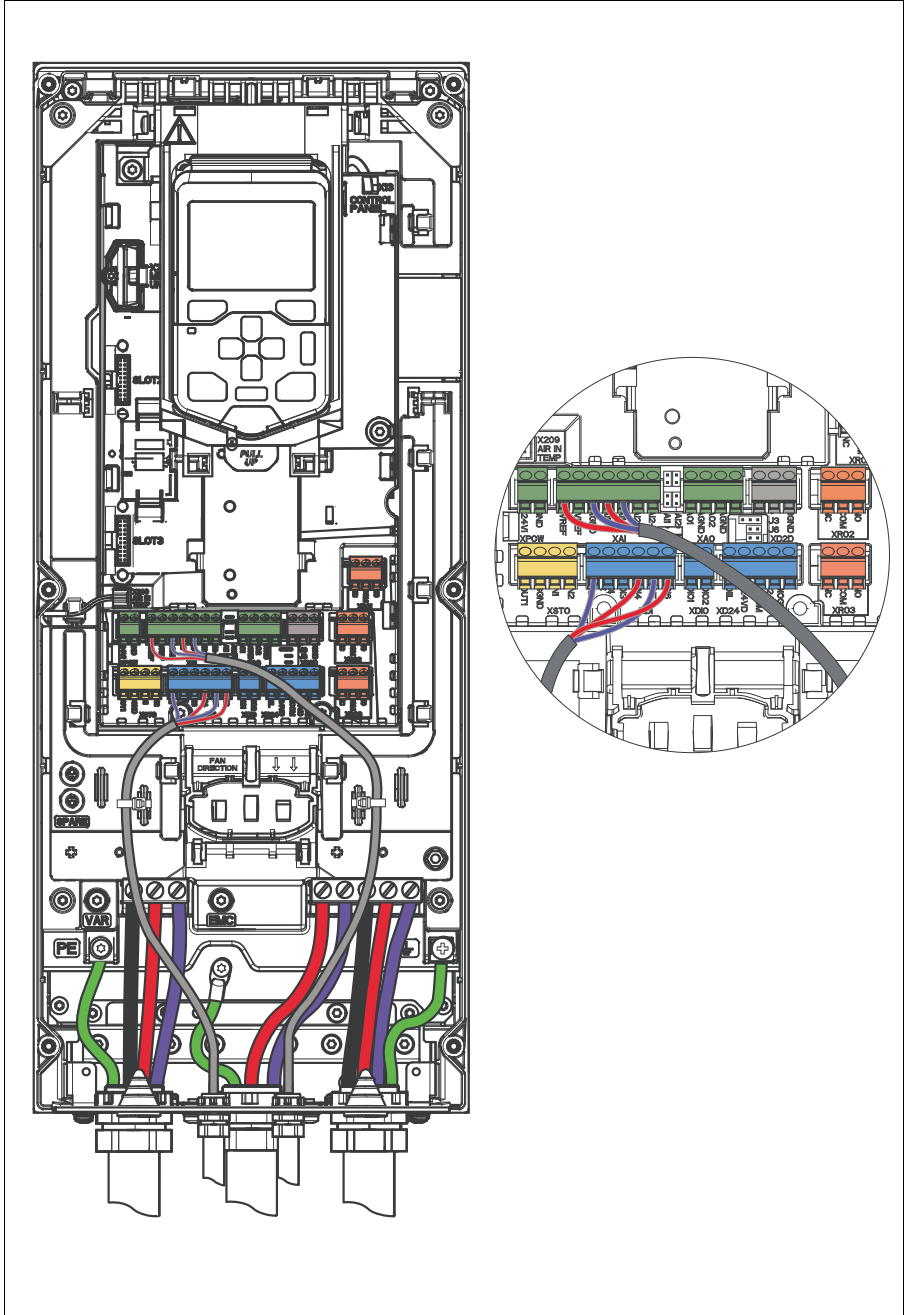

R6

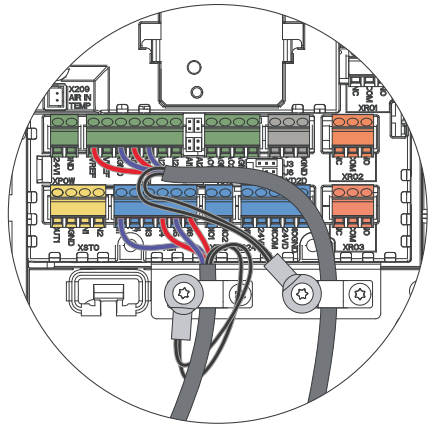
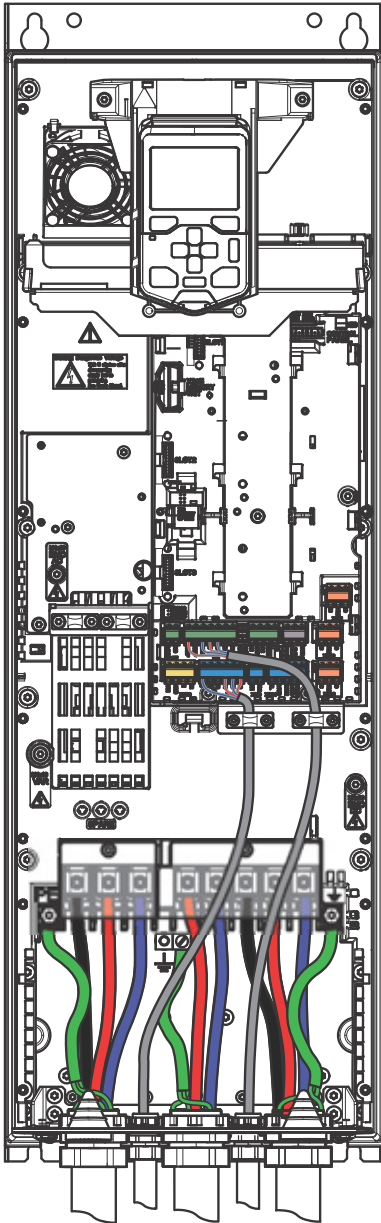

R8

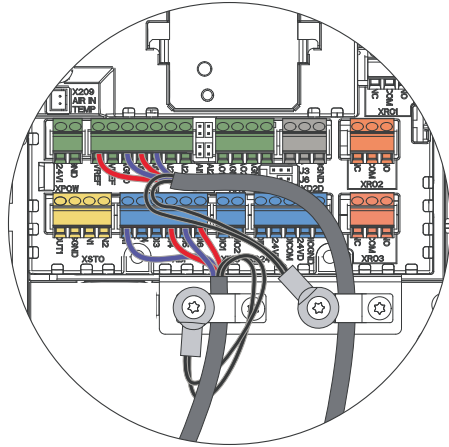
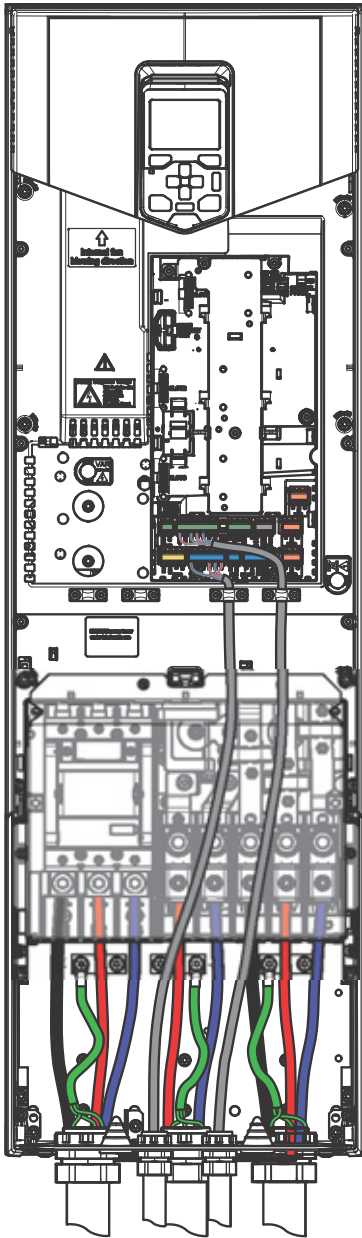

Installing option modules

See section [Installing option modules](#) on page 106.

Reinstalling cover(s)

After installation, reinstall the covers.

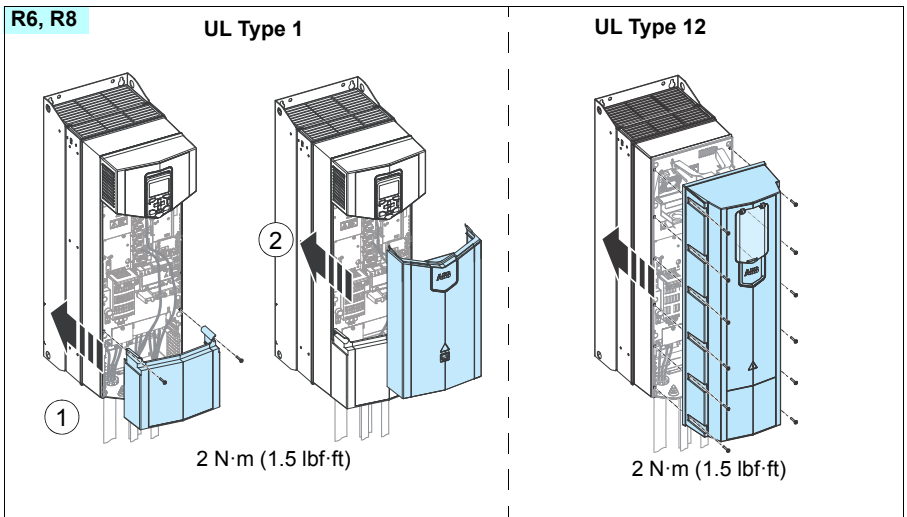

Connecting a PC

See section [Connecting a PC](#) on page 113.

Controlling several drives through the panel bus

See section [Controlling several drives through the panel bus](#) on page 114.



8

Installation checklist

Contents of this chapter

This chapter contains an installation checklist which you must complete before you start up the drive.

Warnings



WARNING! Obey the instructions in chapter [Safety instructions](#) on page 13. If you ignore them, injury or death, or damage to the equipment can occur.

Checklist

Do the steps in section [Precautions before electrical work](#) on page 16 before you start the work. Go through the checklist together with another person.

Check that ...	<input checked="" type="checkbox"/>
The ambient operating conditions meet the specification in section Ambient conditions on page 192.	<input type="checkbox"/>
<u>If the drive will be connected to a corner-grounded TN system:</u> The internal EMC filter has been disconnected. See section Checking the compatibility with IT (ungrounded), corner-grounded delta, midpoint-grounded delta, and TT systems on page 78.	<input type="checkbox"/>
<u>If the drive will be connected to an IT (ungrounded) system:</u> The internal EMC filter and the ground-to-phase varistor has been disconnected. See section Checking the compatibility with IT (ungrounded), corner-grounded delta, midpoint-grounded delta, and TT systems on page 78.	<input type="checkbox"/>

Check that ...	<input checked="" type="checkbox"/>
<u>If the drive has not been powered (either in storage or unused) over three years:</u> The electrolytic DC capacitors in the DC link of the drive have been reformed. See section Reforming the capacitors on page 158.	<input type="checkbox"/>
There is an adequately sized protective earth (ground) conductor between the drive and the switchboard.	<input type="checkbox"/>
There is an adequately sized protective earth (ground) conductor between the motor and the drive.	<input type="checkbox"/>
All protective earth (ground) conductors have been connected to the appropriate terminals and the terminals have been tightened (pull conductors to check).	<input type="checkbox"/>
The supply voltage matches the nominal input voltage of the drive. Check the type designation label.	<input type="checkbox"/>
The input power cable has been connected to appropriate terminals, the phase order is correct, and the terminals have been properly tightened. (Pull conductors to check.)	<input type="checkbox"/>
Appropriate supply fuses and disconnectors have been installed.	<input type="checkbox"/>
The motor cable has been connected to appropriate terminals, the phase order is right, and the terminals have been tightened. (Pull conductors to check.)	<input type="checkbox"/>
The brake resistor cable (if present) has been connected to appropriate terminals, and the terminals have been tightened. (Pull conductors to check.)	<input type="checkbox"/>
The motor cable (and brake resistor cable, if present) has been routed away from other cables.	<input type="checkbox"/>
The control cables (if any) have been connected to the control unit.	<input type="checkbox"/>
<u>If a drive bypass connection will be used:</u> The direct-on-line contactor of the motor and the drive output contactor are either mechanically or electrically interlocked (cannot be closed simultaneously).	<input type="checkbox"/>
There are no tools, foreign objects or dust from drilling inside the drive.	<input type="checkbox"/>
Drive and motor connection box covers are in place.	<input type="checkbox"/>
The motor and the driven equipment are ready for start-up.	<input type="checkbox"/>



Start-up

Contents of this chapter

This chapter describes the start-up procedure of the drive.

Start-up procedure

1. Run setup of the drive control program according to the start-up instructions given in *Quick start-up guide for ACS880 primary control program* (3AUA0000098062 [English]) or in the firmware manual.
 - For drives with resistor braking: see also section [Resistor braking](#) on page [225](#).
 - For drives with ABB sine filter, check that parameter **95.15 Special HW settings** is set to **ABB sine filter**. For other sine filters, see *Sine filter hardware manual* (3AXD50000016814 [English]).
 - For drives with ABB motors in explosive atmospheres, see also *ACS880 drives with ABB motors in explosive atmospheres* (3AXD50000019585 [English]).
 2. Validate the Safe torque off function according to the instructions given in chapter [The Safe torque off function](#) on page [213](#).
 3. Validate the safety functions (options +Q923, +Q973 and Q982) as described in *FSO-12 safety functions module user's manual* (3AXD50000015612 [English]), *FSO-21 safety functions module user's manual* (3AXD50000015614 [English]) or *FSPS-21 safety functions fieldbus module user's manual* (3AXD50000158638 [English]).
-

10

Maintenance and hardware diagnostics

Contents of this chapter

The chapter contains preventive maintenance instructions and LED indicator descriptions.

Maintenance intervals

The table below shows the maintenance tasks which can be done by the end user. The complete maintenance schedule is available on the Internet (www.abb.com/drivesservices). For more information, consult your local ABB Service representative (www.abb.com/searchchannels).

Maintenance and component replacement intervals are based on the assumption that the equipment is operated within the specified ratings and ambient conditions. ABB recommends annual drive inspections to ensure the highest reliability and optimum performance.

Note: Long term operation near the specified maximum ratings or ambient conditions may require shorter maintenance intervals for certain components. Consult your local ABB Service representative for additional maintenance recommendations.

■ Description of symbols

Action	Description
I	Visual Inspection and maintenance action if needed
P	Performance of on/off-site work (commissioning, tests, measurements or other work)
R	Replacement of component

■ Recommended annual maintenance actions by the user

Action	Description
P	Quality of supply voltage
I	Spare parts
P	Capacitor reforming, spare modules and spare capacitors (page 158)
I	Tightness of terminals
I	Dustiness, corrosion or temperature
P	Heat sink cleaning (page 149)

■ Recommended maintenance actions by the user

Component	Years from start-up						
	3	6	9	12	15	18	21
Cooling							
Main cooling fan							
Main cooling fans			R			R	
Auxiliary cooling fan							
Auxiliary cooling fan			R			R	
Second auxiliary cooling fan (IP55, UL Type 12)			R			R	
Aging							
Control unit battery (real-time clock)		R		R		R	
Control panel battery (real-time clock)			R			R	

4FPS10000309652

Heatsink

The drive heatsink fins pick up dust from the cooling air. The drive can run into overtemperature warnings and faults if the heatsink is not clean. When necessary, clean the heatsink as follows.



WARNING! Obey the instructions in chapter [Safety instructions](#) on page [13](#). Ignoring the instructions can cause physical injury or death, or damage to the equipment.



WARNING! Use a vacuum cleaner with antistatic hose and nozzle. Using a normal vacuum cleaner creates static discharges which can damage circuit boards.

1. Stop the drive and disconnect it from the power line. Wait for 5 minutes and then make sure by measuring that there is no voltage. See section [Precautions before electrical work](#) on page [16](#) before you start the work.
2. Remove the cooling fan(s). See section [Fans](#) on page [149](#).
3. Blow clean, dry and oil free compressed air from bottom to top and simultaneously use a vacuum cleaner at the air outlet to trap the dust.

Note: If there is a risk of dust entering adjoining equipment, perform the cleaning in another room.
4. Reinstall the cooling fan(s).

Fans

See section [Maintenance intervals](#) on page [147](#) for the fan replacement interval in average operation conditions.

In a speed-controlled fan, the speed of the fan matches the cooling needs. This increases the life span of the fan.

Main fans are speed controlled. When the drive is stopped, the main fan is kept running at low speed to cool the control unit. IP21 (UL Type 1) frames R6 and R8 and all IP55 (UL Type 12) frames have auxiliary fans that are not speed controlled and run all the time when the control unit is powered.

Replacement fans are available from the manufacturer. Do not use other than specified spare parts.

■ Replacing the main cooling fan, frame R3

 **WARNING!** Obey the instructions in chapter [Safety instructions](#) on page 13. If you ignore them, physical injury or death, or damage to the equipment can occur.

1. Stop the drive and disconnect it from the power line. Wait for 5 minutes and then make sure by measuring that there is no voltage. See section [Precautions before electrical work](#) on page 16 before you start the work.
2. To release the locking, turn clockwise with a screwdriver.
3. Turn the fan assembly off.
4. Install the new fan in reverse order.

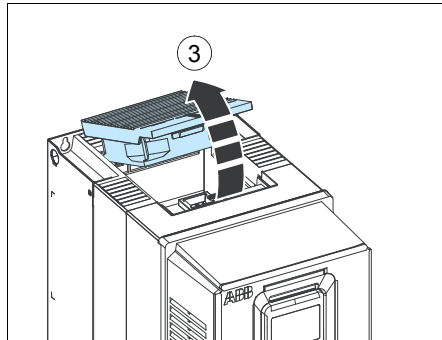
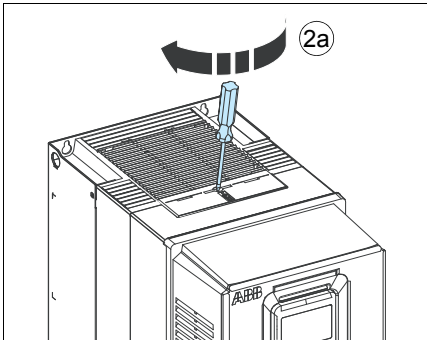

■ Replacing the main cooling fan, frame R6

 **WARNING!** Obey the instructions in chapter *Safety instructions* on page 13. If you ignore them, physical injury or death, or damage to the equipment can occur.

1. Stop the drive and disconnect it from the power line. Wait for 5 minutes and then make sure by measuring that there is no voltage. See section *Precautions before electrical work* on page 16 before you start the work.
2. Lever the fan assembly off the drive frame with for example a screwdriver (2a) and pull out the fan assembly (2b)
3. Pull the fan assembly down.
4. Unplug the fan power supply and grounding wires from the drive.
5. Install the new fan in reverse order.

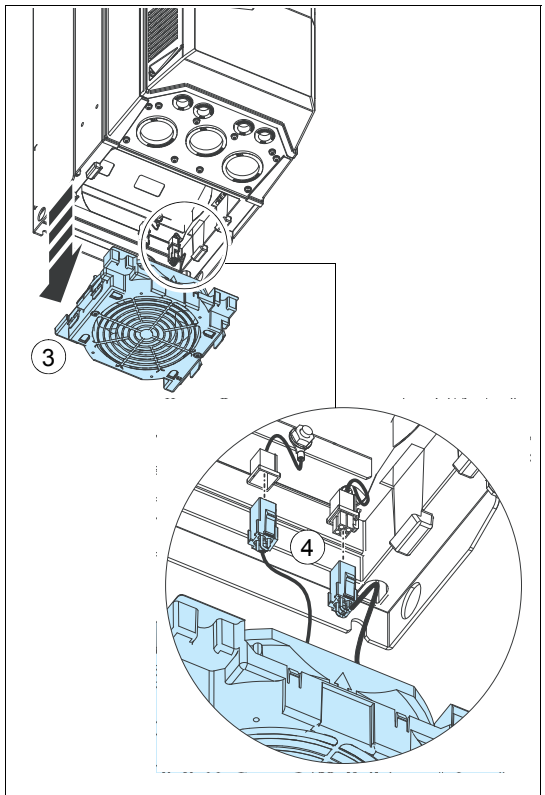
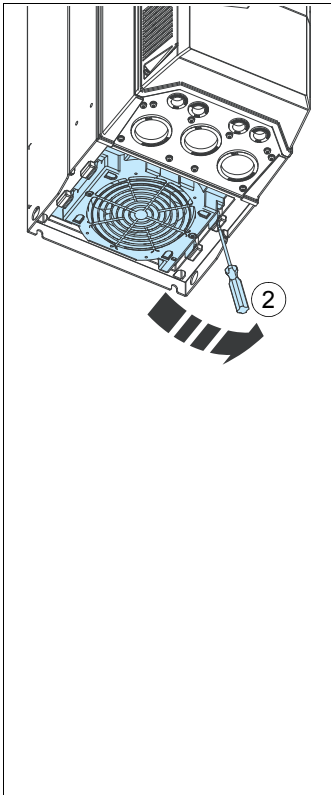

■ Replacing the main cooling fan, frame R8

 **WARNING!** Obey the instructions in chapter [Safety instructions](#) on page 13. Ignoring the instructions can cause physical injury or death, or damage to the equipment.

1. Stop the drive and disconnect it from the power line. Wait for 5 minutes and then make sure by measuring that there is no voltage. See section [Precautions before electrical work](#) on page 16 before you start the work.
2. Undo the mounting screws of the fan assembly.
3. Unplug the fan power supply and grounding wires from the drive.
4. Pull the fan assembly down.
5. Undo the mounting screws of the fan.
6. Install the new fan in reverse order.

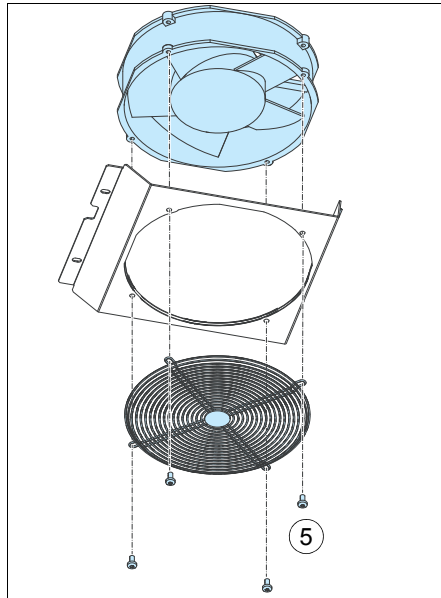
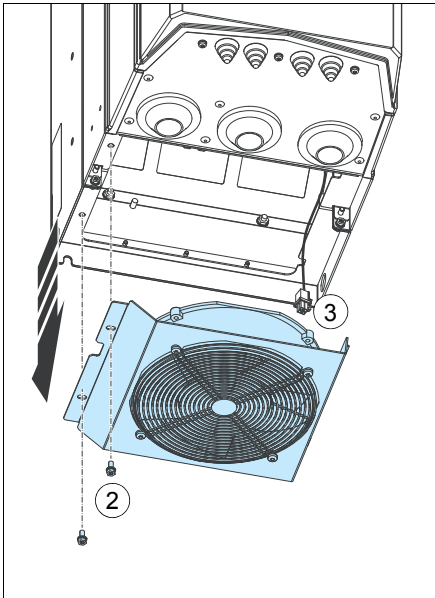

■ Replacing the auxiliary cooling fan, IP55 (UL Type 12) frame R3

 **WARNING!** Obey the instructions in chapter *Safety instructions* on page 13. If you ignore them, physical injury or death, or damage to the equipment can occur.

1. Stop the drive and disconnect it from the power line. Wait for 5 minutes and then make sure by measuring that there is no voltage. See section *Precautions before electrical work* on page 16 before you start the work.
2. Remove the control panel, see section *Control panel* on page 34.
3. Remove the front cover (see page 86).
4. Release the retaining clips.
5. Lift the fan off.
6. Unplug fan power supply wires.
7. Install the new fan in reverse order.

Note: Make sure that the arrow on the fan points down.

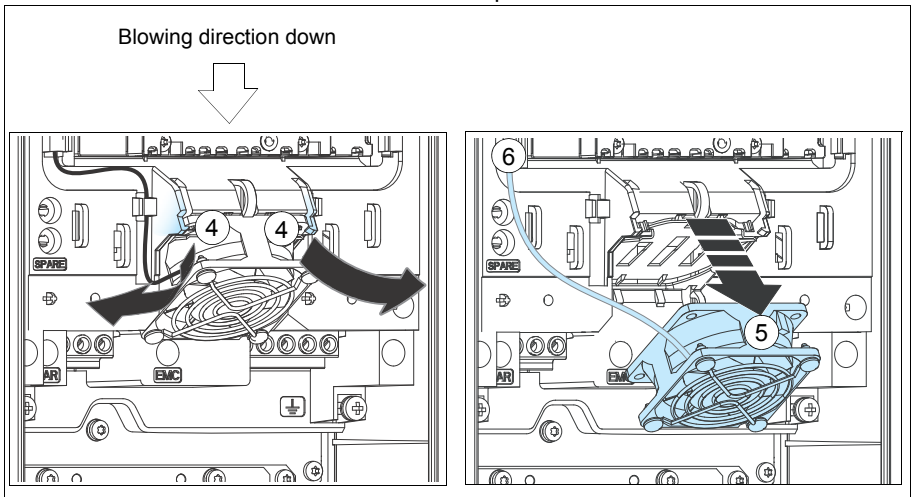

■ Replacing the auxiliary cooling fan, frame R6

 **WARNING!** Obey the instructions in chapter [Safety instructions](#) on page 13. If you ignore them, physical injury or death, or damage to the equipment can occur.

1. Stop the drive and disconnect it from the power line. Wait for 5 minutes and then make sure by measuring that there is no voltage. See section [Precautions before electrical work](#) on page 16 before you start the work.
2. Remove the upper front covers. See section [Connection procedure](#) on page 86.
3. Release the retaining clips.
4. Lift the fan off.
5. Unplug fan power supply wires.
6. Remove the grille from the fan.
7. Install the new fan in reverse order.
Note: Make sure that the arrow on the fan points up.
8. Reinstall the front covers. See section [Reinstalling cover\(s\)](#) on page 112.

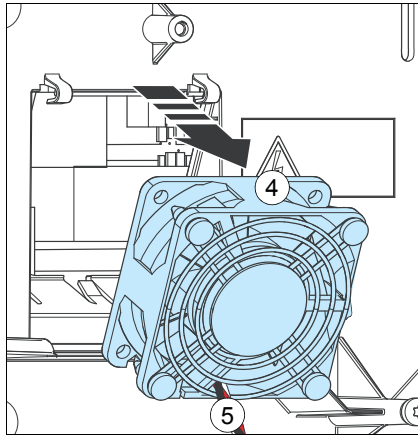
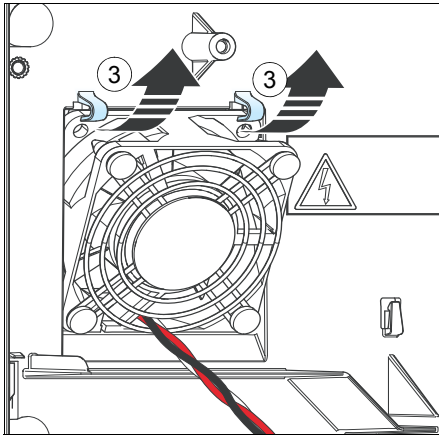

Replacing the auxiliary cooling fan, frame R8



WARNING! Obey the instructions in chapter *Safety instructions* on page 13. If you ignore them, physical injury or death, or damage to the equipment can occur.

1. Stop the drive and disconnect it from the power line. Wait for 5 minutes and then make sure by measuring that there is no voltage. See section *Precautions before electrical work* on page 16 before you start the work.
2. Remove the upper front covers. See section *Connection procedure* on page 86.
3. Release the retaining clips.
4. Lift the fan off.
5. Unplug fan power supply wires.
6. Remove the grille.
7. Install the new fan in reverse order.
Note: Make sure that the arrow on the fan points up.
8. Replace the front covers.

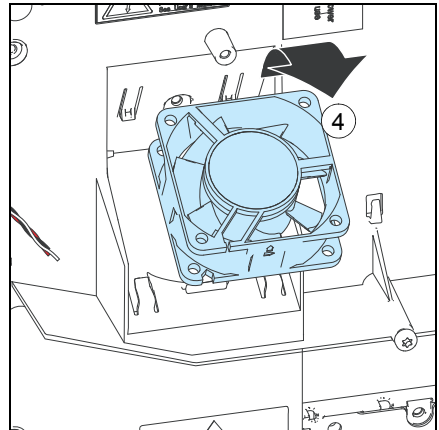
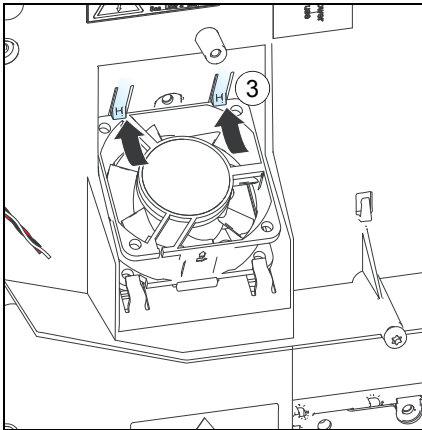

■ Replacing the second auxiliary cooling fan IP55 (UL Type 12), frame R8



WARNING! Obey the instructions in chapter [Safety instructions](#) on page [13](#). If you ignore them, physical injury or death, or damage to the equipment can occur.

1. Stop the drive and disconnect it from the power line. Wait for 5 minutes and then make sure by measuring that there is no voltage. See section [Precautions before electrical work](#) on page [16](#) before you start the work.
 2. Remove the IP55 front cover.
 3. Remove the lower front cover from the IP55 cover.
 4. Unplug the fan power supply wires.
 5. Remove the fan.
 6. Install the new fan in reverse order. Make sure that the arrow on the fan points up.
-

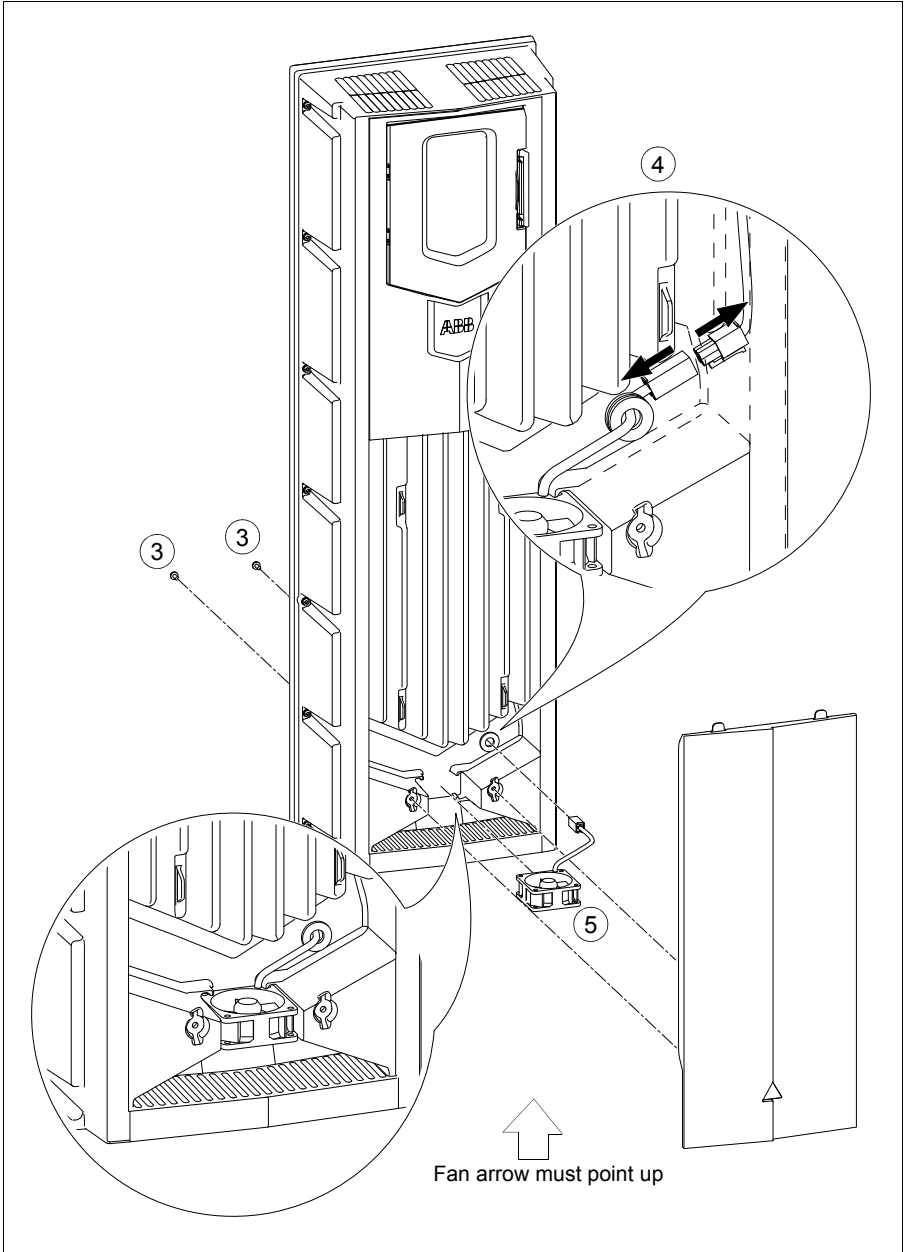

Capacitors

The drive intermediate DC circuit employs several electrolytic capacitors. Their lifespan depends on the operating time of the drive, loading and ambient temperature. Capacitor life can be prolonged by lowering the ambient temperature.

Capacitor failure is usually followed by damage to the drive and an input cable fuse failure, or a fault trip. Contact ABB if capacitor failure is suspected. Replacements are available from the manufacturer. Do not use other than specified spare parts.

■ Reforming the capacitors

Reform the capacitors if the drive has not been powered for three years or more. The reforming is done by powering the unit not loaded for 60 minutes. See section [Type designation label](#) on page 35 for how to find out the manufacturing date from the serial number. For information on reforming the capacitors, see *Converter module capacitor reforming instructions* (3BFE64059629 [English]).

Memory unit

When a drive is replaced, the parameter settings can be retained by transferring the memory unit from the defective drive to the new drive. The memory unit is located on the control unit.



WARNING! Do not remove or insert a memory unit when the drive is powered or the control unit is powered from an external power source.

After power-up, the drive will scan the memory unit. If different parameter settings are detected, they are copied to the drive. This may take several minutes.

Control panel

■ Cleaning the control panel

Use a soft damp cloth to clean the control panel. Avoid harsh cleaners which could scratch the display window.

■ Replacing the battery in the control panel

A battery is used in all control panels to keep the clock operating in memory during power interruptions.

The expected life for the battery is greater than ten years.

Note: The battery is NOT required for any control panel or drive functions, except the clock.

1. Remove the control panel from the drive. See section [Control panel](#) on page 34.
2. To remove the battery, use a coin to rotate the battery cover on the back of the control panel.
3. Replace the battery with type CR2032. Dispose the old battery according to local disposal rules or applicable laws.

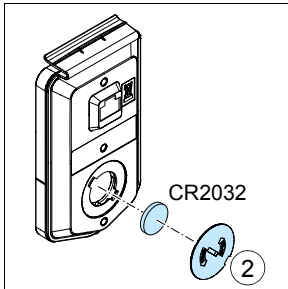

LEDs

■ Drive LEDs

There is a green POWER and a red FAULT LED visible when the control panel is removed. If a control panel is attached to the drive, switch to remote control (otherwise a fault will be generated), and then remove the panel to be able to see the LEDs .

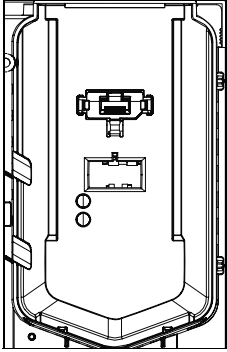

The table below describes the drive LED indications.

LEDs off	LED lit and steady		LED blinking	
No power	Green (POWER)	Power supply on the unit OK	Green (POWER)	<u>Blinking:</u> Drive in an alarm state <u>Blinking for one second:</u> Drive selected on the control panel when multiple drives are connected to the same panel bus.
	Red (FAULT)	Active fault in the drive. To reset the fault, press RESET from the control panel or switch off the drive power.	Red (FAULT)	Active fault in the drive. To reset the fault, switch off the drive power.

■ Control panel LEDs

The assistant control panel has one LED. For the meaning of the LED indications, see *ACX-AP-x assistant control panels user's manual* ([3AUA0000085685](#) [English]).

11

Technical data

Contents of this chapter

The chapter contains the technical specifications of the drive, for example ratings, sizes and technical requirements as well as provisions for fulfilling the requirements for CE, UL and other approval marks.

Ratings

IEC ratings

Type ACS880 -31-	Frame size	Input rating	Max. current	App. power	Output ratings					
					Nominal use		Light-duty use		Heavy-duty use	
					I_1	I_{max}	S_N	I_2	P_N	I_{Ld}
		A	A	kVA	A	kW	A	kW	A	kW
3-phase $U_N = 400\text{ V (380...415 V)}$										
09A4-3	R3	8	13.6	6.9	10.0	4.0	9.5	4.0	8.0	3.0
12A6-3	R3	10	17.0	8.9	12.9	5.5	12.0	5.5	10.0	4.0
017A-3	R3	14	21.9	12	17.0	7.5	16	7.5	12.9	5.4
025A-3	R3	20	28.8	17	25	11	24	11	17	7.5
032A-3	R6	27	42.5	22	32	15	30	15	25	11
038A-3	R6	33	54.4	26	38	18.5	36	18.5	32	15.0
045A-3	R6	40	64.6	31	45	22	43	22	38	18.5
061A-3	R6	51	76.5	42	61	30	58	30	45	22
072A-3	R6	63	103.7	50	72	37	68	37	61	30
087A-3	R6	76	122.4	60	87	45	83	45	72	37
105A-3	R8	88	148	73	105	55	100	55	87	45
145A-3	R8	120	178	100	145	75	138	75	105	55
169A-3	R8	144	247	117	169	90	161	90	145	75
206A-3	R8	176	287	143	206	110	196	110	169	90

Type ACS880 -31-	Frame size	Input rating	Max. current	App. power	Output ratings					
					Nominal use		Light-duty use		Heavy-duty use	
					I_1	I_{max}	S_N	I_{Ld}	P_{Ld}	I_{Hd}
A	A	kVA	A	kW	A	kW	A	kW		
3-phase $U_N = 500\text{ V}$ (380...500 V)										
07A6-5	R3	7	9.5	6.6	7.6	4.0	7.2	4.0	5.2	2.2
11A0-5	R3	9	13.8	9.5	11.0	5.5	10.4	5.5	7.6	4.0
014A-5	R3	12	18.7	12	14	7.5	13	7.5	11.0	5.5
021A-5	R3	17	26.3	18	21	11.0	19	11.0	14	7.5
027A-5*	R6	24	35.7	23	27	15.0	26	15.0	21	11.0
034A-5*	R6	29	45.9	29	34	18.5	32	18.5	27	15.0
040A-5*	R6	34	57.8	35	40	22.0	38	22.0	34	18.5
052A-5*	R6	44	68.0	45	52	30.0	49	30.0	40	22.0
065A-5*	R6	54	88.4	56	65	37.0	62	37.0	52	30.0
077A-5*	R6	66	110.5	67	77	45.0	73	45.0	65	37.0
101A-5	R8	72	148	87	101	55.0	91	55.0	77	45.0
124A-5	R8	88	178	107	124	75.0	118	75.0	96	55.0
156A-5	R8	120	247	137	156	90.0	148	90.0	124	75.0
180A-5	R8	144	287	156	180	110.0	171	110.0	156	90.0

3AXD00000588487

* These ratings are not to be used for drives with degree of protection of IP55 (UL Type 12) option +B056.

UL (NEC) ratings

Type ACS880 -31-	Frame size	Input rating	Max. current	App. power	Output ratings			
					Nominal use		Heavy-duty use	
					I_{Ld}	P_{Ld}	I_{Hd}	P_{Hd}
A	hp	A	hp					
3-phase $U_N = 480\text{ V}$ (440...480 V)								
07A6-5	R3	5,8	9.5	6.6	7.6	5.0	5.2	3.0
11A0-5	R3	7,8	13.8	9.5	11.0	7.5	7.6	5.0
014A-5	R3	10,6	18.7	12	14.0	10.0	11.0	7.5
021A-5	R3	15,6	26.3	18	21.0	15.0	14.0	10.0
027A-5*	R6	21,3	35.7	23	27.0	20.0	21.0	15.0
034A-5*	R6	26,2	45.9	29	34.0	25.0	27.0	20.0
040A-5*	R6	31,2	57.8	35	40.0	30.0	34.0	25.0
052A-5*	R6	40,1	68.0	45	52.0	40.0	40.0	30.0
065A-5*	R6	49,5	88.4	56	65.0	50.0	52.0	40.0
077A-5*	R6	60,2	110.5	67	77.0	60.0	65.0	50.0
101A-5	R8	74	148	87	96.0	75.0	77.0	60.0
124A-5	R8	100	178	107	124.0	100.0	96.0	75.0
156A-5	R8	120	247	137	156.0	125.0	124.0	100.0
180A-5	R8	147	287	156	180.0	150.0	156.0	125.0

3AXD00000588487

* These ratings are not to be used for drives with degree of protection of IP55 (UL Type 12) option +B056.

See definitions and notes on page 165.

■ Definitions

U_N	Nominal voltage of the drive. For input voltage range, see section Electrical power network specification on page 183.
I_1	Nominal input current (rms) at 40 °C (104 °F)
I_{max}	Maximum output current. Available for two seconds at start. Then as long as allowed by drive temperature.
I_2	Nominal output current. Maximum continuous rms output current allowed (no overload). This is indicated in the type designation label as output current I2.
P_N	Nominal power of the drive. Typical motor power (no overloading). The kilowatt ratings apply to most IEC 4-pole motors. The horsepower ratings apply to most NEMA 4-pole motors.
I_{Ld}	Maximum current with 10% overload, allowed for one minute every five minutes
P_{Ld}	Typical motor power in light-duty use (110% overload)
I_{Hd}	Maximum current with 50% overload, allowed for one minute every five minutes
	1) Maximum current with 30% overload, allowed for one minute every five minutes
	2) Maximum current with 25% overload, allowed for one minute every five minutes
P_{Hd}	Typical motor power in heavy-duty use (50% overload)

■ Sizing

Drive sizing is based on the rated motor current and power. To achieve the rated motor power given in the table, the rated current of the drive must be higher than or equal to the rated motor current. Also the rated power of the drive must be higher than or equal to compared to the rated motor power. The power ratings are the same regardless of the supply voltage within one voltage range.

Note: ABB recommends the DriveSize dimensioning tool (available from <http://new.abb.com/drives/software-tools/drivesize>) for selecting the drive, motor and gear combination.

Derating

The load capacity (I_2 , I_{Ld} , I_{Hd} ; note that I_{max} is not derated) decreases for certain situations, as defined below. In such situations, where full motor power is required, oversize the drive so that the derated value provides sufficient capacity.

■ Ambient temperature derating, IP21 (UL Type 1)

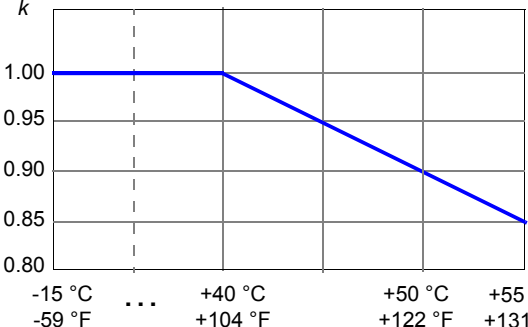
Temperature range	Derating																		
up to +40 °C up to +104 °F	No derating																		
+40...+55 °C +104...+131 °F	<p data-bbox="266 284 980 367">Derate 1% for every 1 °C (1.8 °F): Calculate the output by multiplying the current given in the rating table by the derating factor (k, in the diagram below).</p>  <table border="1" data-bbox="296 375 823 702"> <caption>Derating Factor (k) vs. Temperature (T)</caption> <thead> <tr> <th>Temperature (°C)</th> <th>Temperature (°F)</th> <th>Derating Factor (k)</th> </tr> </thead> <tbody> <tr> <td>-15</td> <td>-59</td> <td>1.00</td> </tr> <tr> <td>40</td> <td>104</td> <td>1.00</td> </tr> <tr> <td>50</td> <td>122</td> <td>0.95</td> </tr> <tr> <td>55</td> <td>131</td> <td>0.90</td> </tr> <tr> <td>131</td> <td>268</td> <td>0.85</td> </tr> </tbody> </table>	Temperature (°C)	Temperature (°F)	Derating Factor (k)	-15	-59	1.00	40	104	1.00	50	122	0.95	55	131	0.90	131	268	0.85
Temperature (°C)	Temperature (°F)	Derating Factor (k)																	
-15	-59	1.00																	
40	104	1.00																	
50	122	0.95																	
55	131	0.90																	
131	268	0.85																	

Ambient temperature derating, IP55 (UL Type 12)

The derating is the same as for degree of protection of IP21 (UL Type 1) except for drive types shown below.

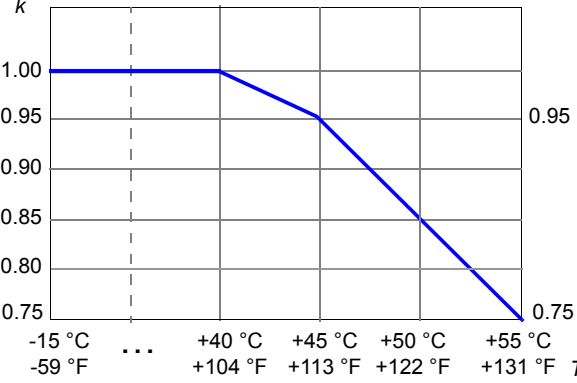
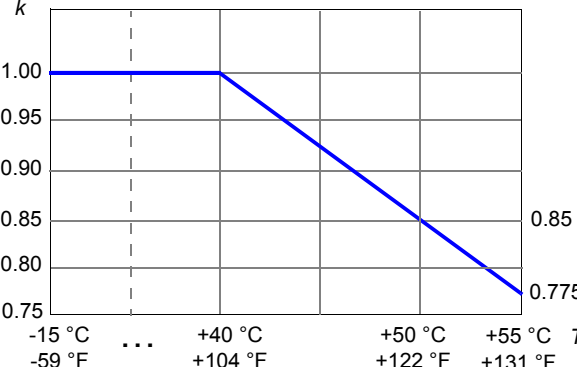
Temperature range	Derating																					
ACS880-31-087A-3+B056 and -077A-5+B056																						
up to +40 °C up to +104 °F	No derating																					
+40...+55 °C +104...+131 °F	<p>Derate 1% for every 1 °C (1.8 °F) up to 45 °C (113 °F): Derate 2% for every 1 °C (1.8 °F) up to 55 °C (131 °F). Calculate the output by multiplying the current given in the rating table by the derating factor (k, in the diagram below).</p>  <table border="1" data-bbox="352 502 929 885"> <caption>Derating Factor (k) vs Temperature (T)</caption> <thead> <tr> <th>Temperature (°C)</th> <th>Temperature (°F)</th> <th>Derating Factor (k)</th> </tr> </thead> <tbody> <tr><td>-15</td><td>-59</td><td>1.00</td></tr> <tr><td>...</td><td>...</td><td>...</td></tr> <tr><td>+40</td><td>+104</td><td>1.00</td></tr> <tr><td>+45</td><td>+113</td><td>0.95</td></tr> <tr><td>+50</td><td>+122</td><td>0.85</td></tr> <tr><td>+55</td><td>+131</td><td>0.75</td></tr> </tbody> </table>	Temperature (°C)	Temperature (°F)	Derating Factor (k)	-15	-59	1.00	+40	+104	1.00	+45	+113	0.95	+50	+122	0.85	+55	+131	0.75
Temperature (°C)	Temperature (°F)	Derating Factor (k)																				
-15	-59	1.00																				
...																				
+40	+104	1.00																				
+45	+113	0.95																				
+50	+122	0.85																				
+55	+131	0.75																				
ACS880-31-206A-3+B056 and 180A-5+B056																						
up to +40 °C up to +104 °F	No derating																					
+40...+55 °C +104...+131 °F	<p>Derate 1.5% for every 1 °C (1.8 °F): Calculate the output by multiplying the current given in the rating table by the derating factor (k, in the diagram below).</p>  <table border="1" data-bbox="352 1077 929 1444"> <caption>Derating Factor (k) vs Temperature (T)</caption> <thead> <tr> <th>Temperature (°C)</th> <th>Temperature (°F)</th> <th>Derating Factor (k)</th> </tr> </thead> <tbody> <tr><td>-15</td><td>-59</td><td>1.00</td></tr> <tr><td>...</td><td>...</td><td>...</td></tr> <tr><td>+40</td><td>+104</td><td>1.00</td></tr> <tr><td>+50</td><td>+122</td><td>0.85</td></tr> <tr><td>+55</td><td>+131</td><td>0.775</td></tr> </tbody> </table>	Temperature (°C)	Temperature (°F)	Derating Factor (k)	-15	-59	1.00	+40	+104	1.00	+50	+122	0.85	+55	+131	0.775			
Temperature (°C)	Temperature (°F)	Derating Factor (k)																				
-15	-59	1.00																				
...																				
+40	+104	1.00																				
+50	+122	0.85																				
+55	+131	0.775																				

Note: For ambient temperatures above +40 °C (+104 °F), the power cables must be rated for 90 °C (194 °F) minimum.

■ Ambient temperature derating in table format

Type ACS880 -31-	≤ 40 °C IP21, IP55		45 °C IP21, IP55		50 °C IP21, IP55		55 °C IP21, IP55	
	%	I_2 (A)	%	(A)	%	I_{out} (A)	%	I_{out} (A)
3-phase $U_N = 400$ V (38...415 V)								
09A4-3	100	10.0	95	9.5	90	9.0	85	8.5
12A6-3	100	12.9	95	12.3	90	11.6	85	11.0
017A-3	100	17.0	95	16.2	90	15.3	85	14.5
025A-3	100	25	95	23.8	90	22.5	85	21.3
032A-3	100	32	95	30.4	90	28.8	85	27.2
038A-3	100	38	95	36.1	90	34.2	85	32.3
045A-3	100	45	95	42.8	90	40.5	85	38.3
061A-3	100	61	95	58.0	90	54.9	85	51.9
072A-3	100	72	95	68.4	90	64.8	85	61.2
087A-3	100	87	95	82.7	90/85	78.3/74	85/75	74/65.3
105A-3	100	105	95	99,8	90	94,5	85	89,3
145A-3	100	145	95	137,8	90	130,5	85	123,3
169A-3	100	169	95	160,6	90	152,1	85	143,7
206A-3	100	206	92.5	190,6	85	175,1	77,5	159,7
3-phase $U_N = 500$ V (380...500 V)								
07A6-5	100	7.6	95/95	7.2	90/90	6.8	85/85	6.5
11A0-5	100	11.0	95/95	10.5	90/90	9.9	85/85	9.4
014A-5	100	14	95/95	13.3	90/90	12.6	85/85	11.9
021A-5	100	21	95/95	20.0	90/90	18.9	85/85	17.9
027A-5	100	27	95/95	25.7	90/90	24.3	85/85	23.0
034A-5	100	34	95/95	32.3	90/90	30.6	85/85	28.9
040A-5	100	40	95/95	38.0	90/90	36.0	85/85	34.0
052A-5	100	52	95/95	49.4	90/90	46.8	85/85	44.2
065A-5	100	65	95/95	61.8	90/90	58.5	85/85	55.3
077A-5	100	77	95/95	73.2	90/85*	69.3/65.5*	85/75*	65.5/57.8*
101A-5	100	101	95	96,0	90	90,9	85	85,9
124A-5	100	124	95	117,8	90	111,6	85	105,4
156A-5	100	156	95	148,2	90	140,4	85	132,6
180A-5	100	180	92,5	166,5	85	153,0	77,5	139,5

3AXD0000588487

* IP55

Deratings for special settings in the drive control program

Enabling special settings in the drive control program can require output current derating.

- drive is used with an ABB motor for explosive atmospheres (Ex) and *EX motor* in Parameter **95.15 Special HW settings** is enabled
- sine filter given in the selection table on page 232 is used and *ABB Sine filter* in Parameter **95.15 Special HW settings** is enabled
- *Low noise optimization* is selected in Parameter **97.09 Switching freq mode**.

Note: If Ex motors are used together with sine filters, *EX motor* in Parameter **95.15 Special HW settings** is disabled and *ABB Sine filter* in Parameter **95.15 Special HW settings** is enabled. Obey the instructions of the motor manufacturer.

Type ACS880 -31-	Output ratings							
	EX motor (ABB Ex motors)				ABB Sine filter			
	Nominal use		Light-duty use	Heavy-duty use	Nominal use		Light-duty use	Heavy-duty use
	I_N	P_N	I_{Ld}	I_{Hd}	I_N	P_N	I_{Ld}	I_{Hd}
	A	kW	A	A	A	kW	A	A
$U_N = 400\text{ V}$								
09A4-3	10.0	4.0	9.5	8.0	9.2	4.0	8.7	7.2
12A6-3	12.9	5.5	12.0	10.0	12.1	5.5	11.5	9.2
017A-3	17	8	16	12.6	16	7.5	15	12
025A-3	25	11	24	17	24	11	23	16
032A-3	32	15	30	25	31	15	29	23
038A-3	38	19	36	32	37	18.5	35	31
045A-3	45	22	43	38	43	22	41	36
061A-3	61	30	58	45	58	30	55	43
072A-3	72	37	68	61	64	30	61	58
087A-3	87	45	83	72	77	37	73	64
105A-3	105	55	100	87	105	55	100	87
145A-3	145	75	138	105	145	75	138	105
169A-3	169	90	161	145	169	90	161	145
206A-3	206	110	196	169	206	110	196	169
$U_N = 500\text{ V}$								
07A6-5	7.6	4.0	7.2	5.2	7.0	3.0	6.7	4.8
11A0-5	11.0	5.5	10.4	7.6	10.2	4.0	9.7	7.0
014A-5	14	7.5	13	11	13	5.5	12	10.2
021A-5	21	11.0	19	14	19	7.5	18	13
027A-5	27	15	26	21	25	11.0	24	19.0
034A-5	34	18.5	32	27.0	31	15	29	25
040A-5	40	22	38	34	34	18.5	32	31.0

Type ACS880 -31-	Output ratings							
	EX motor (ABB Ex motors)				ABB Sine filter			
	Nominal use		Light-duty use	Heavy-duty use	Nominal use		Light-duty use	Heavy-duty use
	I_N	P_N	I_{Ld}	I_{Hd}	I_N	P_N	I_{Ld}	I_{Hd}
	A	kW	A	A	kW	A	A	
052A-5	52	30	49	40	44	22	42	34
065A-5	65	37	62	52	52	30	49	44
077A-5	77	45	73	65	61	37	58	52
101A-5	101	45,0	91	45	101	45,0	91	45
124A-5	124	55,0	118	55	124	55,0	118	55
156A-5	156	75,0	148	75	156	75,0	148	75
180A-5	180	90,0	171	90	180	90,0	171	90

3AXD00000588487

U_N	Supply voltage range
I_N	Nominal output current (available continuously with no over-loading)
P_N	Typical motor power in no-overload use
I_{Ld}	Continuous rms output current allowing 10% overload for 1 minute every 5 minutes
I_{Hd}	Continuous rms output current allowing 50% overload for 1 minute every 5 minutes.
P_{Hd}	Typical motor power in heavy-duty use
Note 1: The ratings apply at an ambient temperature of 40 °C (104 °F).	

Type ACS880 -31-	Output ratings with selection Low noise optimization of parameter Parameter 97.09 Switching freq mode		
	Nominal use	Light-duty use	Heavy-duty use
	I_N	I_{Ld}	I_{Hd}
	A	A	A
$U_N = 400\text{ V}$			
09A4-3	8.5	8.1	6.5
12A6-3	11.3	10.7	8.5
017A-3	15	14.3	11.3
025A-3	22	20.9	15.0
032A-3	30	29	22
038A-3	35	33	30
045A-3	41	39	35
061A-3	56	53	41
072A-3	56	53	47
087A-3	67	64	56
105A-3	105	100	87

Type ACS880 -31-	Output ratings with selection Low noise optimization of parameter Parameter 97.09 Switching freq mode		
	Nominal use	Light- duty use	Heavy-duty use
	I_N	I_{Ld}	I_{Hd}
	A	A	A
145A-3	145	138	105
169A-3	169	161	145
206A-3	206	196	169
$U_N = 500\text{ V}$			
07A6-5	6.5	6.2	4.4
11A0-5	9.4	8.9	6.5
014A-5	12.0	11.4	9.4
021A-5	18.0	17.1	12.0
027A-5	23.0	21.9	18.0
034A-5	29	28	23
040A-5	29	28	23
052A-5	37	35	29
065A-5	39	37	33
077A-5	46	44	39
101A-5	101	91	77
124A-5	124	118	96
156A-5	156	148	124
180A-5	180	171	156

3AXD0000588487

U_N	Supply voltage range
I_N	Nominal output current (available continuously with no over-loading)
P_N	Typical motor power in no-overload use
I_{Ld}	Continuous rms output current allowing 10% overload for 1 minute every 5 minutes
I_{Hd}	Continuous rms output current allowing 50% overload for 1 minute every 5 minutes.
P_{Hd}	Typical motor power in heavy-duty use

Note 1: The ratings apply at an ambient temperature of 40 °C (104 °F).

High speed mode

Selection **High speed mode** of parameter **95.15 Special HW settings** improves control performance at high output frequencies. We recommend it to be selected with output frequency of 120 Hz and above.

This table gives the drive ratings for the maximum output frequency when **High speed mode** in parameter **95.15 Special HW settings** is enabled: With output frequencies smaller than this recommended maximum output frequency, the current derating is less than the values given in the table. Contact ABB for operation above the recommended maximum output frequency or for the output current derating with output frequencies above 120 Hz and below the maximum output frequency.

At the output frequency 120 Hz no derating.

Type ACS880 -31-	Output ratings with selection High speed mode of parameter 95.15 Special HW settings			
	Maximum output frequency	Nominal use	Light-duty use	Heavy-duty use
	f_{max}	I_N	I_{Ld}	I_{Hd}
	Hz	A	A	A
$U_N = 400\text{ V}$				
09A4-3	500	8.5	8.1	6.5
12A6-3	500	11.3	10.7	8.5
017A-3	500	15	14.3	11.3
025A-3	500	22	20.9	15.0
032A-3	500	30	29	22
038A-3	500	35	33	30
045A-3	500	41	39	35
061A-3	500	56	53	41
072A-3	500	56	53	47
087A-3	500	67	64	56
105A-3	500	105	100	87
145A-3	500	145	138	105
169A-3	500	156	148	122
206A-3	500	192	180	155
$U_N = 500\text{ V}$				
07A6-5	500	6.5	6.2	4.4
11A0-5	500	9.4	8.9	6.5
014A-5	500	12.0	11.4	9.4
021A-5	500	18.0	17.1	12.0
027A-5	500	23.0	21.9	18.0
034A-5	500	29	28	23
040A-5	500	29	28	23
052A-5	500	37	35	29

Type ACS880 -31-	Output ratings with selection High speed mode of parameter 95.15 Special HW settings			
	Maximum output frequency	Nominal use	Light-duty use	Heavy-duty use
	f_{max}	I_N	I_{Ld}	I_{Hd}
	Hz	A	A	A
065A-5	500	39	37	33
077A-5	500	46	44	39
101A-5	500	101	91	77
124A-5	500	124	118	96
156A-5	500	144	136	87
180A-5	500	169	160	147

3AXD0000588487

f_{max}	Maximum output frequency with High speed mode
U_N	Nominal voltage of the drive
I_N	Continuous rms output current. No overload capability at 40 °C (104 °F)
P_N	Typical motor power in no-overload use.
I_{Ld}	Continuous rms output current allowing 10% overload for 1 minute every 5 minutes
I_{Hd}	Continuous rms output current allowing 50% overload for 1 minute every 5 minutes

■ Altitude derating

In altitudes 1000...4000 m (3300...13120 ft) above sea level, the derating is 1% for every 100 m (330 ft).

The output current is calculated by multiplying the current given in the rating table by the derating factor k, which for x meters (1000 m ≤ x ≤ 4000 m) is:

$$k = 1 - \frac{1}{10\,000\text{ m}} \cdot (x - 1000)\text{ m}$$

Check the network compatibility restrictions above 2000 m (6562 ft), see [Installation site altitude](#) on page 192.

Fuses (IEC)

Fuses protect the input cable in short-circuit situations. They also restrict drive damage and prevent damage to adjoining equipment in case of a short-circuit inside the drive. ABB recommends the high speed aR fuses specified below. The gG fuses can be used for frames R3 and R6 if they operate rapidly enough (max. 0.1 seconds). The operating time depends on the supply network impedance and the cross-sectional area and length of the supply cable. Obey the local regulations.

Note: Fuses from other manufacturers can be used if they meet the ratings and the melting curve of the fuse does not exceed the melting curve of the fuse mentioned in the table.

■ aR fuses

Type ACS880 -31-	Min. short- circuit current ¹⁾	Input current	aR				
			Nominal current	I^2t	Voltage rating	Bussmann type	IEC 60269 size
	A	A	A	A ² s	V		
3-phase $U_N = 400\text{ V}$ (380...415 V)							
09A4-3	65	8	25	130	690	170M1561	000
12A6-3	65	10	25	130	690	170M1561	000
017A-3	120	14	40	460	690	170M1563	000
025A-3	120	20	40	460	690	170M1563	000
032A-3	170	27	63	1450	690	170M1565	000
038A-3	170	33	63	1450	690	170M1565	000
045A-3	280	40	80	2550	690	170M1566	000
061A-3	380	51	100	4650	690	170M1567	000
072A-3	480	63	125	8500	690	170M1568	000
087A-3	700	76	160	16000	690	170M1569	000
105A-3	1280	88	315	46500	690	170M3817	1
145A-3	1280	120	315	46500	690	170M3817	1
169A-3	1800	144	450	105000	690	170M5809	2
206A-3	2210	176	500	145000	690	170M5810	2
3-phase $U_N = 500\text{ V}$ (380...500 V)							
07A6-5	65	7	25	130	690	170M1561	000
11A0-5	65	9	25	130	690	170M1561	000
014A-5	120	12	40	460	690	170M1563	000
021A-5	120	17	40	460	690	170M1563	000
027A-5	170	24	63	1450	690	170M1565	000
034A-5	170	29	63	1450	690	170M1565	000
040A-5	280	34	80	2550	690	170M1566	000
052A-5	300	44	100	4650	690	170M1567	000
065A-5	480	54	125	8500	690	170M1568	000
077A-5	700	66	160	16000	690	170M1569	000
101A-5	1000	72	250	28500	690	170M3816	1
124A-5	1280	88	315	46500	690	170M3817	1

Type ACS880 -31-	Min. short- circuit current ¹⁾	Input current	aR				
			Nominal current	I^2t	Voltage rating	Bussmann type	IEC 60269 size
			A	A	A		
156A-5	1610	120	400	74000	690	170M5808	2
180A-5	2210	144	500	155000	690	170M5810	2

3AXD0000588487

¹⁾ Minimum short-circuit current of the installation

■ gG fuses

gG fuses can be used for frames R3 and R6 if they operate rapidly enough (max. 0.1 seconds).

Type ACS880 -31-	Min. short- circuit current ¹⁾	Input current	gG (IEC 60269)				
			Nominal current	I^2t	Voltage rating	ABB type	IEC 60269 size
			A	A	A		
3-phase $U_N = 400\text{ V}$ (380...415 V)							
09A4-3	120	8.0	16	700	500	OFAF000H16	000
12A6-3	120	10.0	16	700	500	OFAF000H16	000
017A-3	200	14.0	25	2500	500	OFAF000H25	000
025A-3	250	20.0	32	4500	500	OFAF000H32	000
032A-3	350	27.0	40	7700	500	OFAF000H40	000
038A-3	400	33.0	50	15400	500	OFAF000H50	000
045A-3	500	40.0	63	21300	500	OFAF000H63	000
061A-3	800	51.0	80	37000	500	OFAF000H80	000
072A-3	1000	63.0	100	63600	500	OFAF000H100	000
087A-3	1000	76.0	100	63600	500	OFAF000H100	000
3-phase $U_N = 500\text{ V}$ (380...500 V)							
07A6-5	120	7.0	16	700	500	OFAF000H16	000
11A0-5	120	9.0	16	700	500	OFAF000H16	000
014A-5	200	12.0	25	2500	500	OFAF000H25	000
021A-5	250	17.0	32	4500	500	OFAF000H32	000
027A-5	350	24.0	40	7700	500	OFAF000H40	000
034A-5	400	29.0	50	15400	500	OFAF000H50	000
040A-5	500	34.0	63	21300	500	OFAF000H63	000
052A-5	800	44.0	80	37000	500	OFAF000H80	000
065A-5	1000	54.0	100	63600	500	OFAF000H100	000
077A-5	1000	66.0	100	63600	500	OFAF000H100	000

3AXD0000588487

¹⁾ Minimum short-circuit current of the installation

■ Quick guide for selecting between gG and aR fuses

The combinations (cable size, cable length, transformer size and fuse type) in this table fulfill the minimum requirements for the correct operation of the fuse. Use this table to select between gG and aR fuses or calculate the short-circuit current of the

installation as described in section [Calculating the short-circuit current of the installation](#) on page 176.

Type ACS880 -31-	Cable type		Supply transformer minimum apparent power S_N (kVA)					
	Copper	Aluminum	Maximum cable length with gG fuses			Maximum cable length with aR fuses		
	mm ²	mm ²	10 m	50 m	100 m	10 m	100 m	200 m
$U_N = 400 \text{ V}$								
09A4-3	3×1.5	-	5.8	6.2	8.4	3.1	3.4	5.0
12A6-3	3×1.5	-	5.8	6.2	8.4	3.1	3.4	5.0
017A-3	3×6	-	9.6	9.8	10	5.8	5.9	6.2
025A-3	3×6	-	12	12	13	5.8	5.9	6.2
032A-3	3×10	-	17	17	18	8.2	8.3	8.7
038A-3	3×10	-	19	20	21	8.2	8.3	8.7
045A-3	3×16	3×25	24	24	26	13	14	15
061A-3	3×25	3×25	39	39	42	18	19	20
072A-3	3×35	3×35	48	49	52	23	24	25
087A-3	3×35	3×50	48	49	52	34	35	38
$U_N = 500 \text{ V}$								
07A6-5	3×1.5	-	7.2	7.5	8.9	3.9	4.1	5.0
11A0-5	3×1.5	-	7.2	7.5	8.9	3.9	4.1	5.0
014A-5	3×6	-	12	12	12	7.2	7.3	7.6
021A-5	3×6	-	15	15	16	7.2	7.3	7.6
027A-5	3×10	-	21	21	22	10	10	11
034A-5	3×10	-	24	24	25	10	10	11
040A-5	3×16	3×35	30	30	31	17	17	18
052A-5	3×25	3×35	48	49	51	18	18	19
065A-5	3×35	3×50	60	61	63	29	29	30
077A-5	3×35	3×70	60	61	63	42	43	46

■ Calculating the short-circuit current of the installation

Check that the short-circuit current of the installation is at least the value given in the fuse table.

The short-circuit current of the installation can be calculated as follows:

$$I_{k2-ph} = \frac{U}{2 \cdot \sqrt{R_c^2 + (Z_k + X_c)^2}}$$

where

I_{k2-ph} Short-circuit current in symmetrical two-phase short-circuit
 U Network line-to-line voltage (V)

R_c	Cable resistance (ohm)
Z_k	$z_k \cdot U_N^2 / S_N$ = transformer impedance (ohm)
z_k	Transformer impedance (%)
U_N	Transformer rated voltage (V)
S_N	Nominal apparent power of the transformer (kVA)
X_c	Cable reactance (ohm)

Calculation example

Drive:

- ACS880-31-072A-3
- supply voltage = 410 V

Transformer:

- rated power S_N = 600 kVA
- rated voltage (drive supply voltage) U_N = 430 V
- transformer impedance z_k = 7.2%.

Supply cable:

- length = 170 m
- resistance/length = 0.398 ohm/km
- reactance/length = 0.082 ohm/km.

$$Z_k = z_k \cdot \frac{U_N^2}{S_N} = 0.072 \cdot \frac{(430 \text{ V})^2}{600 \text{ kVA}} = 22.19 \text{ mohm}$$

$$R_c = 170 \text{ m} \cdot 0.398 \frac{\text{ohm}}{\text{km}} = 67.66 \text{ mohm}$$

$$X_c = 170 \text{ m} \cdot 0.082 \frac{\text{ohm}}{\text{km}} = 13.94 \text{ mohm}$$

$$I_{k2\text{-ph}} = \frac{410 \text{ V}}{2 \cdot \sqrt{(67.66 \text{ mohm})^2 + (22.19 \text{ mohm} + 13.94 \text{ mohm})^2}} = 2.7 \text{ kA}$$

The calculated short-circuit current 2.7 kA is higher than the minimum short-circuit current of the drive gG fuse type OFAF000H100 (1000 A). -> The 500 V gG fuse (ABB Control OFAF000H100) can be used.

Fuses (UL)

UL class T fuses for branch circuit protection per NEC are listed below. ABB recommends fast acting class T or faster fuses in the USA. **Check on the fuse time-current curve to ensure the operating time of the fuse is below 0.5 seconds for frames R3 and R6 and below 0.1 seconds for frame R8. Obey the local regulations.**

Note 1: See also [Implementing thermal overload and short-circuit protection](#) on page 67.

Note 2: Fuses with higher current rating than the recommended ones must not be used.

Note 3: Fuses from other manufacturers can be used if they meet the ratings and the melting curve of the fuse does not exceed the melting curve of the fuse mentioned in the table.

Type ACS880 -31-	Input current	UL (one fuse per phase)			
		Nominal current	Voltage rating	Bussmann type	UL class
		A	V		
3-phase $U_N = 500 \text{ V (380...500 V)}$					
07A6-5	7	15	600	JJS-15	T
11A0-5	9	20	600	JJS-20	T
014A-5	12	25	600	JJS-25	T
021A-5	17	35	600	JJS-35	T
027A-5	24	40	600	JJS-40	T
034A-5	29	50	600	JJS-50	T
040A-5	34	60	600	JJS-60	T
052A-5	44	80	600	JJS-80	T
065A-5	54	90	600	JJS-90	T
077A-5	66	110	600	JJS-110	T
101A-5	72	150	600	JJS-150	T
124A-5	88	200	600	JJS-200	T
156A-5	120	225	600	JJS-225	T
180A-5	144	300	600	JJS-300	T

3AXD00000588487

Dimensions, weights and free space requirements

Frame size	Height	Width	Depth	Weight	Height	Width	Depth	Weight
	mm	mm	mm	kg	mm	mm	mm	kg
	IP21				IP55 (option +B056)			
R3	495	205	356	23	490	203	360	23
R6	771	252	382	74	771	252	445	74
R8	965	300	430	112*	966	300	496	118**
	IP20 (option +P940)				IP20 (option +P944)			
R3	490	203	349	18.3	-	-	-	-
R6	771	252	349	59	-	-	-	-
R8	965	300	430	109***	-	-	-	-

* for types -105A-3, 145A-3, -101A-5, -124A-5: 102 kg

** for types -105A-3, 145A-3, -101A-5, -124A-5: 108 kg

*** for types -105A-3, 145A-3, -101A-5, -124A-5: 99 kg

Frame size	Height	Width	Depth	Weight	Height	Width	Depth	Weight
	in	in	in	lb	in	in	in	lb
	UL Type 1				UL Type 12			
R3	19.49	8.07	14.02	50.72	19.29	7.99	14.17	50.72
R6	30.35	9.92	15.03	161.85	30.35	9.92	17.54	161.85
	UL Open Type (option +P940)				UL Open Type (option +P944)			
R3	19.29	7.99	13.74	40.34	-	-	-	-
R6	30.35	9.92	14.09	130.07	-	-	-	-
R8	37.95	11.81	16.94	240.30***	-	-	-	-

* for types -105A-3, 145A-3, -101A-5, -124A-5: 224.87 lb

** for types -105A-3, 145A-3, -101A-5, -124A-5: 238.10 lb

*** for types -105A-3, 145A-3, -101A-5, -124A-5: 218.26 lb

Free space requirements

See section [Examining the installation site](#) on page 40.

Losses, cooling data and noise

The air flow direction is from bottom to top.

This table shows typical heat loss values, required air flow and noise at the nominal ratings of the drive. The heat loss values can vary depending on voltage, cable conditions, motor efficiency and power factor. To obtain more accurate values for given conditions, use ABB DriveSize tool (<http://new.abb.com/drives/software-tools/drivesize>)

Type ACS880- 31-	Heat dissipation	Air flow		Noise	Frame size
	W	m ³ /h	ft ³ / min	dB(A)	
3-phase $U_N = 400$ (380...415 V)					
09A4-3	226	361	212	57	R3
12A6-3	329	361	212	57	R3
017A-3	395	361	212	57	R3
025A-3	579	361	212	57	R3
032A-3	625	550	324	65	R6
038A-3	751	550	324	65	R6
045A-3	912	550	324	65	R6
061A-3	1088	550	324	65	R6
072A-3	1502	550	324	65	R6
087A-3	1904	550	324	65	R6
105A-3	1877	700	412	68	R8
145A-3	2963	700	412	68	R8
169A-3	3168	700	412	68	R8
206A-3	3990	805	412	68	R8
3-phase $U_N = 500$ V (380...500 V)					
07A6-5	219	361	212	57	R3
11A0-5	278	361	212	57	R3
014A-5	321	361	212	57	R3
021A-5	473	361	212	57	R3
027A-5	625	550	324	65	R6
034A-5	711	550	324	65	R6
040A-5	807	550	324	65	R6
052A-5	960	550	324	65	R6
065A-5	1223	550	324	65	R6
077A-5	1560	550	324	65	R6
101A-5	1995	700	412	68	R8
124A-5	2800	700	412	68	R8
156A-5	3168	700	412	68	R8
180A-5	3872	805	412	68	R8

3AXD00000588487

Terminal and entry data for the power cables

IEC

Input, motor and DC cable entries, maximum wire sizes (per phase) and terminal screw sizes and tightening torques are given below.

Frame size	Cable entries		L1, L2, L3 terminals			T1/U, T2/V, T3/W, UD+, UDC-terminals		
	Per cable type	Ø ¹⁾	Min wire size (solid/stranded) ²⁾	Max wire size (solid/stranded)	Tightening torque	Min wire size (solid/stranded) ²⁾	Max wire size (solid/stranded)	Tightening torque
	pcs	mm	mm ²	mm ²	N·m	mm ²	mm ²	N·m
R3	1	23	0.5	16.0	1.7	0.5	16.0	1.7
R6	1	45	6.0	70.0	5.6	6.0	70.0	5.6
R8	1	45	16	150	33.9	25	150	30

3AXD00000586715

¹⁾ Maximum cable diameter accepted. For the bottom plate hole diameters, see chapter [Dimension drawings](#) on page 203.

²⁾ Minimum wire size does not necessarily have enough current capability for full load. Make sure the installation complies with local laws and regulations.

Note: Only copper cables are allowed for drive types up to -039A-4.

For tightening torques of grounding terminals, see section [Connection procedure](#), page 86.

UL

Input, motor and DC cable entries, maximum wire sizes (per phase) and terminal screw sizes and tightening torques are given below.

Frame size	Cable entries		L1, L2, L3 terminals			T1/U, T2/V, T3/W, UDC+, UDC-terminals		
	Per cable type	Ø ¹⁾	Min wire size (solid/stranded) ²⁾	Max wire size (solid/stranded)	Tightening torque	Min wire size (solid/stranded) ²⁾	Max wire size (solid/stranded)	Tightening torque
	pcs	in	AWG	AWG	lbf·ft	AWG	AWG	lbf·ft
R3	1	0.91	20	6	1.3	20	6	1.3
R6	1	1.77	10	2/0	4.1	10	2/0	4.1
R8	1	1.77	6	300	25	4	300	22

3AXD00000586715

¹⁾ Maximum cable diameter accepted. For the bottom plate hole diameters, see chapter [Dimension drawings](#) on page 203..

²⁾ Minimum wire size does not necessarily have enough current capability for full load. Make sure the installation complies with local laws and regulations.

Note: Only copper cables are allowed for drive types up to -039A-4.

For tightening torques of grounding terminals, see section [Connection procedure](#), page 121.

UL listed cable lugs and tools

Wire size kcmil/AWG	Compression lug		Crimping tool		
	Manufacturer	Type	Manufacturer	Type	No. of crimps
6	Thomas & Betts	E10731	Thomas & Betts	TBM4S	1
		54136		TBM45S	
	Burndy	YAV6C-L2	Burndy	MY29-3	1
	IlSCO	CCL-6-38	IlSCO	ILC-10	2
4	Thomas & Betts	54140	Thomas & Betts	TBM4S	1
	Burndy	YA4C-L4BOX	Burndy	MY29-3	1
	IlSCO	CCL-4-38	IlSCO	MT-25	1
2	Thomas & Betts	54143TB	Thomas & Betts	TBM4S	1
		54142TB		TBM4S	
	Burndy	YA2C-L4BOX	Burndy	MY29-3	2
	IlSCO	CRC-2	IlSCO	IDT-12	1
	IlSCO	CCL-2-38	IlSCO	MT-25	1
1	Thomas & Betts	54148	Thomas & Betts	TBM-8	3
	Burndy	YA1C-L4BOX	Burndy	MY29-3	2
	IlSCO	CRA-1-38	IlSCO	IDT-12	1
	IlSCO	CCL-1-38	IlSCO	MT-25	1
1/0	Thomas & Betts	54109	Thomas & Betts	TBM-8	3
	Burndy	YA25-L4BOX	Burndy	MY29-3	2
	IlSCO	CRB-0	IlSCO	IDT-12	1
	IlSCO	CCL-1/0-38	IlSCO	MT-25	1
2/0	Thomas & Betts	54110	Thomas & Betts	TBM-8	3
	Burndy	YAL26T38	Burndy	MY29-3	2
	IlSCO	CRA-2/0	IlSCO	IDT-12	1
	IlSCO	CCL-2/0-38	IlSCO	MT-25	1

Terminal and entry data for the control cables

■ IEC

Control cable entries, wire sizes and tightening torques (T) are given below.

Frame size	Cable entries		Control cable entries and terminal sizes			
	Holes	Max cable size	+24V, DCOM, DGND, EXT. 24V terminals		DI, AI/O, AGND, RO, STO terminals	
			Wire size	T	Wire size	T
	pcs	mm	mm ²	N·m	mm ²	N·m
R3	4	17	0.2...2.5	0.5...0.6	0.14...2.5	0.5...0.6
R6	4	17	0.14...2.5	0.5...0.6	0.14...2.5	0.5...0.6

Frame size	Cable entries		Control cable entries and terminal sizes			
	Holes	Max cable size	+24V, DCOM, DGND, EXT. 24V terminals		DI, AI/O, AGND, RO, STO terminals	
			Wire size	T	Wire size	T
pcs	mm	mm ²	N·m	mm ²	N·m	
R8	4	17	0.14...2.5	0.5...0.6	0.14...2.5	0.5...0.6

3AXD00000586715

■ US

Control cable entries, wire sizes and tightening torques (T) are given below.

Frame size	Cable entries		Control cable entries and terminal sizes			
	Holes	Max cable size	+24V, DCOM, DGND, EXT. 24V terminals		DI, AI/O, AGND, RO, STO terminals	
			Wire size	T	Wire size	T
pcs	in	AWG	lbf·ft	AWG	lbf·ft	
R3	3	0.67	24...14	0.4	26...14	0.4
R6	4	0.67	26...14	0.4	26...14	0.4
R8	4	0.67	26...14	0.4	26...14	0.4

3AXD00000586715

Electrical power network specification

Voltage (U_1)

ACS880-31-xxxx-3 drives: 380...415 V AC 3-phase +10%...-15%. This is indicated in the type designation label as typical input voltage level 3~ 400 V AC.

ACS880-31-xxxx-5 drives: 380...500 V AC 3-phase . This is indicated in the type designation label as typical input voltage levels 3~ 400/480/500 V AC.

Network type

Public low voltage networks. TN (grounded), IT (ungrounded) . See section [Checking the compatibility with IT \(ungrounded\), corner-grounded delta, midpoint-grounded delta, and TT systems](#) on page 78.

Rated conditional short-circuit current (IEC 60439-1)

65 kA when protected by fuses given in the fuse tables

Short-circuit current protection (UL 61800-5-1)

US and Canada: The drive is suitable for use on a circuit capable of delivering not more than 100 kA symmetrical amperes (rms) at 480 V maximum when protected by fuses given in the fuse table, see page 178.

Frequency (f_1)

47 to 63 Hz. This is indicated in the type designation label as typical input frequency level f_1 (50/60 Hz).

Imbalance

Max. \pm 3% of nominal phase to phase input voltage

Fundamental power factor ($\cos \phi_1$)

1 (at nominal load)

Harmonic distortion

Harmonics are below the limits defined in IEEE519, IEC61000-3-12 and G5/4 standards.

The table below shows typical results on indicated networks. Values are measured at the input terminals of the drive.

R_{sc}	THD voltage (%)	THD current (%)
20	3	2.5*
100	1.9	2.5*

$$THD = \sqrt{\sum_{n=2}^{50} \left(\frac{I_n}{I_{1contmax}} \right)^2}$$

THD Total harmonic distortion. The voltage THD depends on the short-circuit ratio (R_{sc}). The spectrum of the distortion also contains interharmonics.

I_n nth harmonic component

R_{sc} Short-circuit ratio. $R_{scc} = I_{sc}/I_N$

I_{sc} Short-circuit current at point of common coupling (PCC)

$I_{1contmax}$ Continuous maximum input current of the line-side converter

I_L Maximum demand load current

* Other loads can influence the THD value.

Motor connection data**Motor types**

Asynchronous AC induction motors, permanent magnet synchronous motors, AC induction servomotors, synchronous reluctance motors

Frequency (f_2)

0...500 Hz

For drives with du/dt filter: 120 Hz

For drives with sine filter: 120 Hz

Frequency resolution

0.01 Hz

Current

See section [Ratings](#) on page 163.

Maximum recommended motor cable length	For frame R3: 150 m (492 ft)
	For frames R6 and R8: 300 m (984 ft).
	Note 1: With motor cables longer than 150 m (492 ft) or switching frequencies higher than default, the EMC Directive requirements may not be fulfilled.
	Note 2: Longer motor cables cause a motor voltage decrease which limits the available motor power. The decrease depends on the motor cable length and characteristics. Contact ABB for more information. Note that a sine filter (optional) at the drive output also causes a voltage decrease.

Control unit (ZCU-12) connection data

Power supply (XPOW)	24 V ($\pm 10\%$) DC, 2 A Supplied from the power unit of the drive, or from an external power supply through connector XPOW (pitch 5 mm, wire size 2.5 mm ²).
Relay outputs RO1...RO3 (XRO1 ... XRO3)	Connector pitch 5 mm, wire size 2.5 mm ² 250 V AC / 30 V DC, 2 A Protected by varistors
+24 V output (XD24:2 and XD24:4)	Connector pitch 5 mm, wire size 2.5 mm ² Total load capacity of these outputs is 4.8 W (200 mA / 24 V) minus the power taken by DIO1 and DIO2.
Digital inputs DI1...DI6 (XDI:1 ... XDI:6)	Connector pitch 5 mm, wire size 2.5 mm ² 24 V logic levels: "0" < 5 V, "1" > 15 V R_{in} : 2.0 kohm Input type: NPN/PNP (DI1...DI5), NPN (DI6) Hardware filtering: 0.04 ms, digital filtering up to 8 ms DI6 (XDI:6) can alternatively be used as an input for PTC sensors. "0" > 4 kohm, "1" < 1.5 kohm I_{max} : 15 mA (for DI6 5 mA)
Start interlock input DIIL (XD24:1)	Connector pitch 5 mm, wire size 2.5 mm ² 24 V logic levels: "0" < 5 V, "1" > 15 V R_{in} : 2.0 kohm Input type: NPN/PNP Hardware filtering: 0.04 ms, digital filtering up to 8 ms

Digital inputs/outputs DIO1 and DIO2 (XDIO:1 and XDIO:2)

Input/output mode selection by parameters.

DIO1 can be configured as a frequency input (0...16 kHz with hardware filtering of 4 microseconds) for 24 V level square wave signal (sinusoidal or other wave form cannot be used). DIO2 can be configured as a 24 V level square wave frequency output. See the firmware manual, parameter group 11.

Connector pitch 5 mm, wire size 2.5 mm²

As inputs:

24 V logic levels: "0" < 5 V, "1" > 15 V

R_{in} : 2.0 kohm

Filtering: 0.25 ms

As outputs:

Total output current from +24VD is limited to 200 mA.

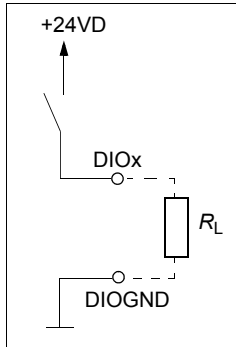

Reference voltage for analog inputs +VREF and -VREF (XAI:1 and XAI:2)

Analog inputs AI1 and AI2 (XAI:4 ... XAI:7).

Current/voltage input mode selection by jumpers. See page 98.

Connector pitch 5 mm, wire size 2.5 mm²

10 V ±1% and -10 V ±1%, R_{load} 1...10 kohm

Connector pitch 5 mm, wire size 2.5 mm²

Current input: -20...20 mA, R_{in} : 100 ohm

Voltage input: -10...10 V, R_{in} : > 200 kohm

Differential inputs, common mode range ±30 V

Sampling interval per channel: 0.25 ms

Hardware filtering: 0.25 ms, adjustable digital filtering up to 8 ms

Resolution: 11 bit + sign bit

Inaccuracy: 1% of full scale range

Inaccuracy for Pt100 sensors: 10 °C (50 °F)

Analog outputs AO1 and AO2 (XAO)

Connector pitch 5 mm, wire size 2.5 mm²

0...20 mA, R_{load} < 500 ohm

Frequency range: 0...300 Hz

Resolution: 11 bit + sign bit

Inaccuracy: 2% of full scale range

Drive to drive link (XD2D)

Connector pitch 5 mm, wire size 2.5 mm²

Physical layer: RS-485

Maximum cable length of the link: 50 m

Cable type: Shielded twisted pair cable with twisted pair for data and a wire or pair for signal ground, nominal impedance 100...165 ohm, for example Belden 9842

Transmission rate: 8 Mbit/s

Termination by switch

**Embedded Modbus RTU
(XD2D)**

Connector pitch 5 mm, wire size 2.5 mm²
 Physical layer: RS-485
 Cable type: Shielded twisted pair cable with twisted pair
 for data and a wire or pair for signal ground, nominal
 impedance 100...165 ohm, for example Belden 9842
 Transmission rate: 9.6...115.2 kbit/s
 Termination by switch

**Safe torque off connection
(XSTO)**

Connector pitch 5 mm, wire size 2.5 mm²
 Input voltage range: -3...30 V DC
 Logic levels: "0" < 5 V, "1" > 17 V
 Current consumption of frames R1 to R7: 30 mA
 (24 V DC, continuous) per STO channel
 Current consumption of frames R8 and R9: 12 mA
 (24 V DC, continuous) per STO channel
 Maximum output current from OUT1: 100 mA
 (24 V DC, continuous)
 For the drive to start, both connections must be closed
 (OUT1 to IN1 and IN2).
 EMC (immunity) according to IEC 61326-3-1

Control panel – PC connection

Connector: RJ-45
 Cable length < 3 m

The terminals on the unit fulfil the Protective Extra Low Voltage (PELV) requirements. The PELV requirements of a relay output are not fulfilled if a voltage higher than 48 V is connected to the relay output.

Ground isolation diagram

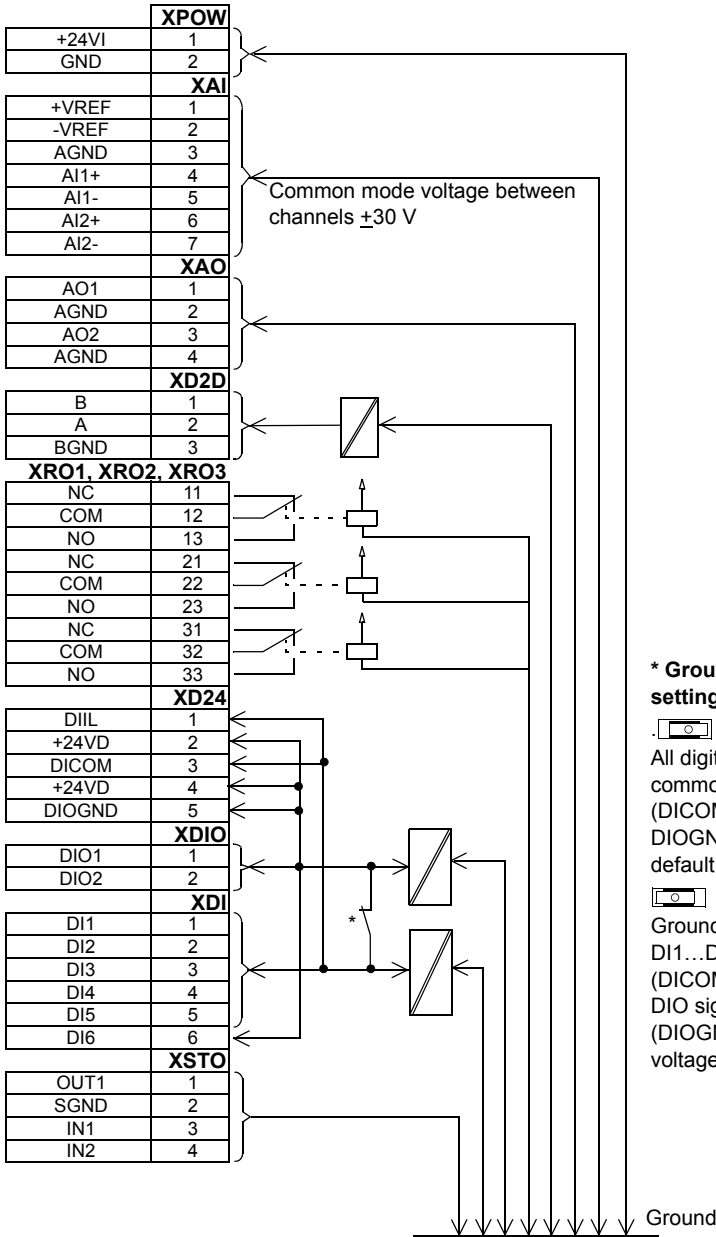

*** Ground selector J6 settings:**



All digital inputs share a common ground (DICOM connected to DIOGND). This is the default setting.



Ground of digital inputs DI1...DI5 and DIIL (DICOM) is isolated from DIO signal ground (DIOGND). Isolation voltage 50 V.

Efficiency

Efficiency at nominal power level:
 Approximately 96% for frame R3
 Approximately 96.5% for frame R6
 Approximately 97% for frame R8

Degree of protection

Degree of protection (IEC/EN 60529)	IP21, IP55, IP20
Enclosure types (UL 61800-5-1)	UL Type 1, UL Type 12, UL Open Type
Overvoltage category (IEC 60664-1)	III
Protective classes (IEC/EN 61800-5-1)	I

Materials

Drive enclosure	<ul style="list-style-type: none"> • PC/ABS 3 mm, color NCS 1502-Y (RAL 9002 / PMS 1C Cool Grey) and RAL 9017 • PC+10%GF 3.0mm, Color RAL 9017 (in two smallest R3 frames only) • Plastic parts are made of UV resistant f1 classified plastics • Hot-dip zinc coated steel sheet 1.5 to 2.5 mm, thickness of coating 100 micrometers, color NCS 1502-Y
------------------------	---

Package

Plywood, cardboard and molded pulp. Foam cushions PE, PP-E, bands PP.

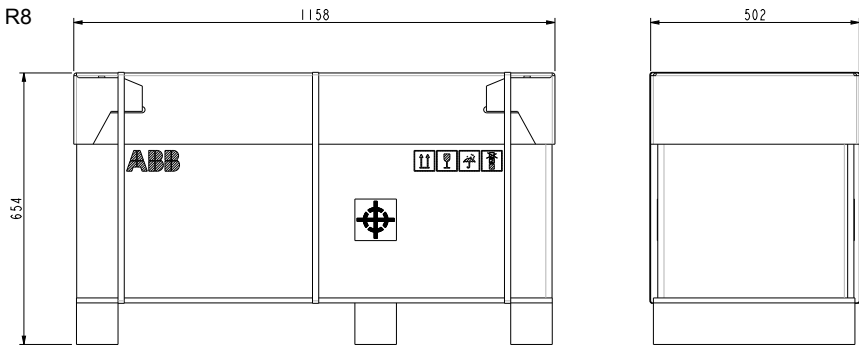
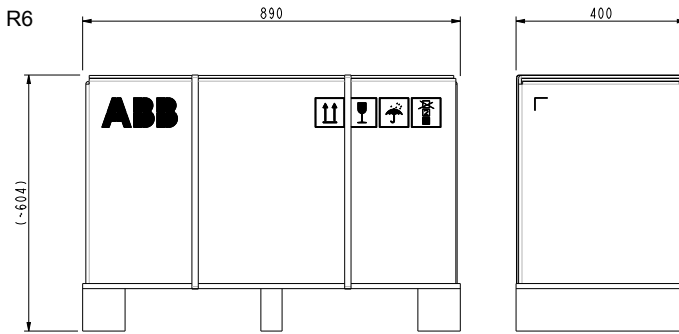
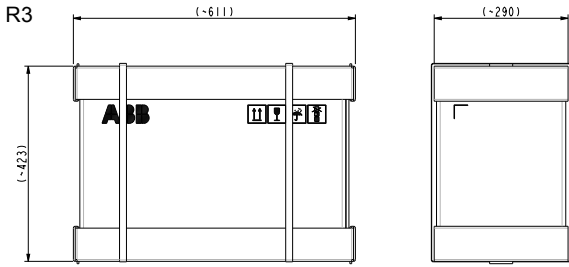

Disposal

The main parts of the drive can be recycled to preserve natural resources and energy. Product parts and materials should be dismantled and separated.

Generally all metals, such as steel, aluminum, copper and its alloys, and precious metals can be recycled as material. Plastics, rubber, cardboard and other packaging material can be used in energy recovery. Printed circuit boards and large electrolytic capacitors need selective treatment according to IEC 62635 guidelines. To aid recycling, plastic parts are marked with an appropriate identification code.

Contact your local distributor for further information on environmental aspects and recycling instructions for professional recyclers. End of life treatment must follow international and local regulations.

Applicable standards

The drive complies with the following standards. The compliance with the European Low Voltage Directive is verified according to standard EN 61800-5-1.

EN 60204-1:2006 + AI:2009 + AC:2010	<i>Safety of machinery. Electrical equipment of machines. Part 1: General requirements. Provisions for compliance:</i> The final assembler of the machine is responsible for installing - emergency-stop device - supply disconnecting device.
IEC/EN 60529:1981 +A1:1999 + A2: 2013	<i>Degrees of protection provided by enclosures (IP code)</i>
EN 61000-3-12:2011	<i>Electromagnetic compatibility (EMC) - Part 3-12: Limits - Limits for harmonic currents produced by equipment connected to public low-voltage systems with input current</i> The standard is met with a Rsce (transformer short circuit ratio) of 350 or higher.
IEC/EN 61800-3:2004 + A1:2012	<i>Adjustable speed electrical power drive systems. Part 3: EMC requirements and specific test methods</i>
IEC/EN 61800-5-1:2007	<i>Adjustable speed electrical power drive systems. Part 5-1: Safety requirements – electrical, thermal and energy</i>
IEC/EN 60664-1:2007	<i>Insulation coordination for equipment within low-voltage systems. Part 1: Principles, requirements and tests.</i>
UL 61800-5-1: First edition 2012	<i>Standard for Adjustable Speed Electrical Power Drive Systems - Part 5-1: Safety Requirements - Electrical, Thermal and Energy</i>
NEMA 250:2014	<i>Enclosures for Electrical Equipment (1000 Volts Maximum)</i>
CSA C22.2 No. 274-17	<i>Industrial control equipment</i>

Ambient conditions

Environmental limits for the drive are given below. The drive is to be used in a heated, indoor, controlled environment. All printed circuit boards are conformal coated.

	Operation installed for stationary use	Storage in the protective package	Transportation in the protective package
Installation site altitude	<ul style="list-style-type: none"> • 0 to 4000 m (13123 ft) above sea level ¹⁾ • 0 to 2000 m (6561 ft) above sea level ²⁾ Output derated above 1000 m (3281 ft), see page 173 .	-	-
Surrounding air temperature	-15 to +55 °C (5 to 131 °F). No frost allowed. See section Ratings .	-40 to +70 °C (-40 to +158 °F)	-40 to +70 °C (-40 to +158 °F)
Relative humidity	5 to 95%	Max. 95%	Max. 95%
	No condensation allowed. Maximum allowed relative humidity is 60% in the presence of corrosive gases.		
Contamination levels (IEC 60721-3-x)	IEC 60721-3-3: 2002: Classification of environmental conditions - Part 3-3: Classification of groups of environmental parameters and their severities - Stationary use of weather protected locations	IEC 60721-3-1: 1997	IEC 60721-3-2: 1997
Chemical gases	Class 3C2	Class 1C2	Class 2C2
Solid particles	Class 3S2. No conductive dust allowed.	Class 1S3 (packing must support this, otherwise 1S2)	Class 2S2
Pollution degree (IEC/EN 61800-5-1)	Pollution degree 2	-	-

	Operation installed for stationary use	Storage in the protective package	Transportation in the protective package
Atmospheric pressure	70 to 106 kPa 0.7 to 1.05 atmospheres	70 to 106 kPa 0.7 to 1.05 atmospheres	60 to 106 kPa 0.6 to 1.05 atmospheres
Vibration (IEC 60068-2:6)	10...150 Hz Amplitude ±0.075 mm, 10...57.56 Hz Constant peak acceleration 10 m/s ² (1 gn), 57.56...150 Hz	-	-
Vibration (ISTA)	-	<u>R3</u> : Displacement, 25 mm peak to peak, 14200 vibratory impacts <u>R6_R8</u> ISTA 3E): Random, overall Grms level of 0.54	
Shock/Drop (ISTA)	Not allowed	<u>R3</u> (ISTA 1A): Drop, 6 faces, 3 edges and 1 corner, 460 mm (18.1 in) <u>R6_R8</u> (ISTA 3E): Shock, incline impact: 1.2 m/s (3.94 ft/s) Shock, rotational edge drop: 230 mm (9.1 in)	

¹⁾ For neutral-grounded TN and TT systems and non-corner grounded IT systems.

²⁾ For corner-grounded TN, TT and IT systems

CE marking

A CE mark is attached to the drive to verify that the drive follows the provisions of the European Low Voltage, EMC and RoHS Directives. The CE marking also verifies that the drive, in regard to its safety functions (such as Safe torque off), conforms with the Machinery Directive as a safety component.

■ Compliance with the European Low Voltage Directive

The compliance with the European Low Voltage Directive has been verified according to standards EN60204-1 and EN 61800-5-1.

■ Compliance with the European EMC Directive

The EMC Directive defines the requirements for immunity and emissions of electrical equipment used within the European Union. The EMC product standard (EN 61800-3:2004 + A1:2012) covers requirements stated for drives. See section [Compliance with the EN 61800-3:2004 + A1:2012](#) below.

■ **Compliance with the European ROHS II Directive**

The RoHS II Directive defines the restriction of the use of certain hazardous substances in electrical and electronic equipment.

■ **Compliance with the European WEEE Directive**

The WEEE Directive defines the regulated disposal and recycling of electric and electrical equipment.

Compliance with the European Machinery Directive

The drive is an electronic product which is covered by the European Low Voltage Directive. However, the drive includes the Safe torque off function and can be equipped with other safety functions for machinery which, as safety components, are in the scope of the Machinery Directive. These functions of the drive comply with European harmonized standards such as EN 61800-5-2.

Declaration of conformity



EU Declaration of Conformity

Machinery Directive 2006/42/EC

We

Manufacturer: ABB Oy
Address: Hiomotie 13, 00380 Helsinki, Finland.
Phone: +358 10 22 11

declare under our sole responsibility that the following products:

Frequency converters

ACS880-01/-11/-31
ACS880-04/-04F/-M04/-14/-34

with regard to the built-in safety function:

Safe torque off;

and with regard to the following optional safety functions with FSO-12 module (option code +Q973, encoderless):

Safe stop 1; Safe stop emergency; Safely-limited speed; Safe maximum speed;
Safe brake control; Prevention of Unexpected Start-up;

and with regard to the following optional safety functions with FSO-21 and FSE-31 modules (option codes +Q972 and +L521):

Safe stop 1; Safe stop emergency; Safely-limited speed; Safe maximum speed;
Safe brake control; Safe speed monitor; Safe direction; Prevention of
Unexpected Start-up;

and with regard to the following optional safety function with FPTC-01 thermistor protection module (option code +L536):

Safe Motor Temperature;

are in conformity with all the relevant safety component requirements of EU Machinery Directive 2006/42/EC, when the listed safety functions are used for safety component functionality.



The following harmonized standards have been applied:

EN 61800-5-2:2007	<i>Adjustable speed electrical power drive systems – Part 5-2: Safety requirements - Functional</i>
EN 62061:2005 + AC:2010 + A1:2013 + A2:2015	<i>Safety of machinery – Functional safety of safety-related electrical, electronic and programmable electronic control systems</i>
EN ISO 13849-1:2015	<i>Safety of machinery – Safety-related parts of control systems. Part 1: General requirements</i>
EN ISO 13849-2:2012	<i>Safety of machinery – Safety-related parts of the control systems. Part 2: Validation</i>
EN 60204-1:2006 + A1:2009 + AC:2010	<i>Safety of machinery – Electrical equipment of machines – Part 1: General requirements</i>

The following other standards have been applied:

IEC 61508:2010	Functional safety of electrical / electronic / programmable electronic safety-related systems
IEC 61800-5-2:2016	Adjustable speed electrical power drive systems – Part 5-2: Safety requirements - Functional

The products referred in this Declaration of conformity fulfil the relevant provisions of other European Union Directives which are notified in Single EU Declaration of conformity 3AXD10000497831.

Person authorized to compile the technical file:

Name and address: Ari Korpela, Hiomotie 13, 00380 Helsinki, Finland.

Helsinki, 29 Jan 2018

Manufacturer representative:

Vesa Kandell
Vice President, ABB Oy

Compliance with the EN 61800-3:2004 + A1:2012

■ Definitions

EMC stands for **E**lectromagnetic **C**ompatibility. It is the ability of electrical/electronic equipment to operate without problems within an electromagnetic environment. Likewise, the equipment must not disturb or interfere with any other product or system within its locality.

First environment includes establishments connected to a low-voltage network which supplies buildings used for domestic purposes.

Second environment includes establishments connected to a network not directly supplying domestic premises.

Drive of category C2: drive of rated voltage less than 1000 V and intended to be installed and started up only by a professional when used in the first environment.

Note: A professional is a person or organization having necessary skills in installing and/or starting up power drive systems, including their EMC aspects.

Drive of category C3: drive of rated voltage less than 1000 V, intended for use in the second environment and not intended for use in the first environment.

■ Category C2

The emission limits are complied with the following provisions:

1. The drive is equipped with EMC filter E202.
2. The motor and control cables are selected as specified in this manual.
3. The drive is installed according to the instructions given in this manual.
4. For the maximum motor cable length with 4 kHz switching frequency, see page [185](#).

WARNING! The drive may cause radio interference if used in residential or domestic environment. The user is required to take measures to prevent interference, in association to the requirements for the CE compliance listed above, if necessary.

Note: Do not install a drive with the internal EMC filter connected on IT (ungrounded). The supply network becomes connected to ground potential through the internal EMC filter capacitors which may cause danger or damage to the drive. For disconnecting the EMC filter see page [82](#).

Note: Do not install a drive with internal EMC filter connected on corner-grounded TN systems; otherwise the drive will be damaged. For disconnecting the internal EMC filter see page [82](#).

■ **Category C3**

The drive complies with the standard with the following provisions:

1. The drive is equipped with EMC filter E200.
2. The motor and control cables are selected as specified in this manual.
3. The drive is installed according to the instructions given in this manual.
4. For the maximum motor cable length with 4 kHz switching frequency, see page [185](#)

WARNING! A drive of category C3 is not intended to be used on a low-voltage public network which supplies domestic premises. Radio frequency interference is expected if the drive is used on such a network.

Category C4

If the provisions under *Category C3* cannot be met, the requirements of the standard can be met as follows:

1. It is ensured that no excessive emission is propagated to neighboring low-voltage networks. In some cases, the inherent suppression in transformers and cables is sufficient. If in doubt, the supply transformer with static screening between the primary and secondary windings can be used.

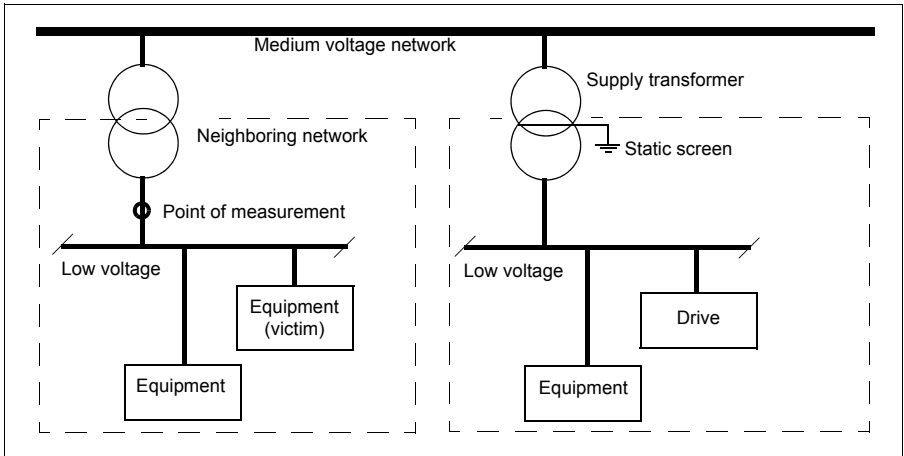

2. An EMC plan for preventing disturbances is drawn up for the installation. A template is available from the local ABB representative.
3. The motor and control cables are selected as specified in this manual.
4. The drive is installed according to the instructions given in this manual.

WARNING! A drive of category C4 is not intended to be used on a low-voltage public network which supplies domestic premises. Radio frequency interference is expected if the drive is used on such a network.

UL marking

These drives are cULus listed:

- frames R3 and R6 (UL Type 1 and UL Type 12)
- frame R8 (UL Type 1).

The cULus listing is pending for frame R8 of UL Type 12.

■ UL checklist



WARNING! Operation of this drive requires detailed installation and operation instructions provided in the hardware and software manuals. The manuals are provided in electric format in the drive package or on the Internet. Retain the manuals with the drive at all times. Hard copies of the manuals can be ordered through the manufacturer.

- Make sure that the drive type designation label includes the cULus Listed marking.
 - **CAUTION - Risk of electric shock.** After disconnecting the input power, always wait for 5 minutes to let the intermediate circuit capacitors discharge before you start working on the drive, motor or motor cable.
 - The drive is to be used in a heated, indoor controlled environment. The drive must be installed in clean air according to the enclosure classification. Cooling air must be clean, free from corrosive materials and electrically conductive dust. UL Type 12 (IP55) enclosure provides protection from airborne dust and light sprays or splashing water from all directions.
 - The maximum surrounding air temperature is +55 °C (131 °F) at rated current. The current is derated for 40 to 55 °C (104 to 131 °F).
 - The drive is suitable for use in a circuit capable of delivering not more than 100,000 rms symmetrical amperes, 480 V maximum when protected by the UL fuses on page 178. The ampere rating is based on tests done according to the appropriate UL standard.
 - The cables located within the motor circuit must be rated for at least 75 °C (167 °F) in UL-compliant installations. For UL Type 12 drives of frame R6, the power cables must be rated for 90 °C (194 °F) minimum. For ambient temperatures above +40 °C (+104 °F), the power cables must be rated for 90 °C (194 °F) minimum.
 - Integral solid state short circuit protection does not provide branch circuit protection. The input cable must be protected with fuses. Suitable IEC (class aR) fuses are listed on page 174 and UL (class T) fuses on page 178. These fuses provide branch circuit protection in accordance with the National Electrical Code (NEC) and Canadian Electrical Code. For installation in the United States, obey any other applicable local codes. For installation in Canada, obey any applicable provincial codes.
-

Note: Circuit breakers must not be used without fuses in the USA. Consult ABB for suitable circuit breakers.



WARNING! The opening of the branch-circuit protective device may be an indication that a fault current has been interrupted. To reduce the risk of fire or electric shock, current-carrying parts and other components of the controller should be examined and replaced if damaged.

- The drive provides motor overload protection. For the adjustments, see the firmware manual.
- For drive overvoltage category, see page [189](#). For pollution degree, see page [192](#).



RCM marking

Regulatory Compliance (RCM) Mark is required in Australia and New Zealand. A RCM mark is attached to the drive to verify compliance with the relevant standard (IEC/EN 61800-3:2004 – *Adjustable speed electrical power drive systems – Part 3: EMC product standard including specific test methods*), mandated by the Trans-Tasman Electromagnetic Compatibility Scheme. For fulfilling the requirements of the standard, see section [Compliance with the EN 61800-3:2004 + A1:2012](#) on page [197](#).



WEEE marking

The drive is marked with the wheeled bin symbol. It indicates that at the end of life the drive should enter the recycling system at an appropriate collection point and not placed in the normal waste stream. See section [Disposal](#) on page [191](#).



China RoHS marking

The *People's Republic of China Electronic Industry Standard* (SJ/T 11364-2014) specifies the marking requirements for hazardous substances in electronic and electrical products. The green mark is attached to the drive to verify that it does not contain toxic and hazardous substances or elements above the maximum concentration values, and that it is an environmentally-friendly product which can be recycled and reused.

EAC marking

The drive has EAC certification. EAC marking is required in Russia, Belarus and Kazakhstan.

Disclaimers

■ General disclaimer

The manufacturer shall have no obligation with respect to any product which (i) has been improperly repaired or altered; (ii) has been subjected to misuse, negligence or accident; (iii) has been used in a manner contrary to the manufacturer's instructions; or (iv) has failed as a result of ordinary wear and tear.

■ Cybersecurity disclaimer

This product is designed to be connected to and to communicate information and data via a network interface. It is Customer's sole responsibility to provide and continuously ensure a secure connection between the product and Customer network or any other network (as the case may be). Customer shall establish and maintain any appropriate measures (such as but not limited to the installation of firewalls, application of authentication measures, encryption of data, installation of anti-virus programs, etc) to protect the product, the network, its system and the interface against any kind of security breaches, unauthorized access, interference, intrusion, leakage and/or theft of data or information. ABB and its affiliates are not liable for damages and/or losses related to such security breaches, any unauthorized access, interference, intrusion, leakage and/or theft of data or information.

12

Dimension drawings

Contents of this chapter

This chapter shows the dimension drawings of the drive. The dimensions are given in millimeters and [inches].

R3, IP21 (UL Type 1)

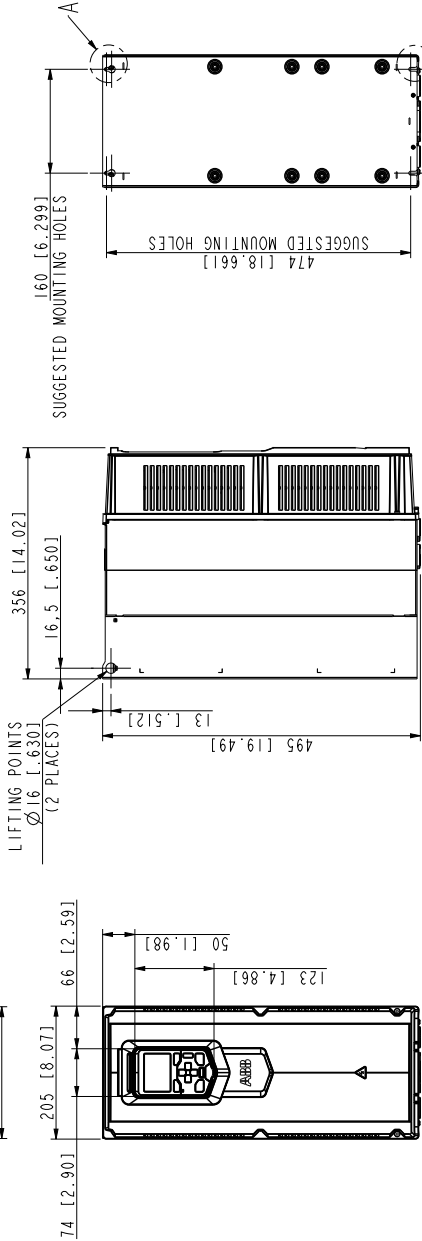
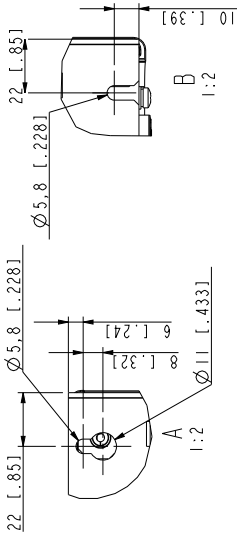
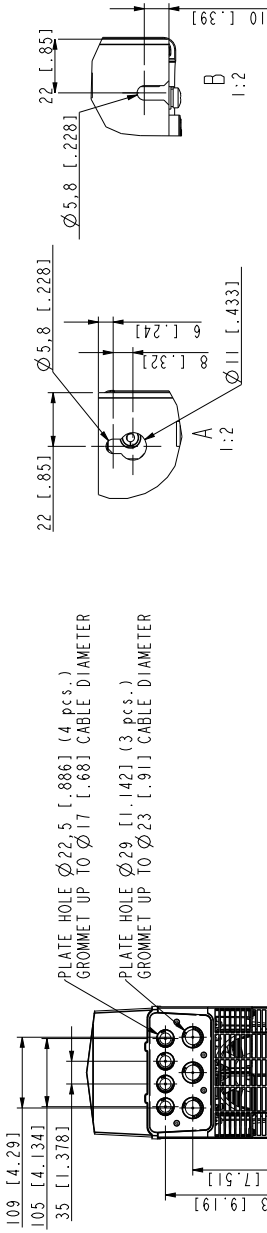

3AXD50000045323

R3 – Option +B056 (IP55, UL Type 12)

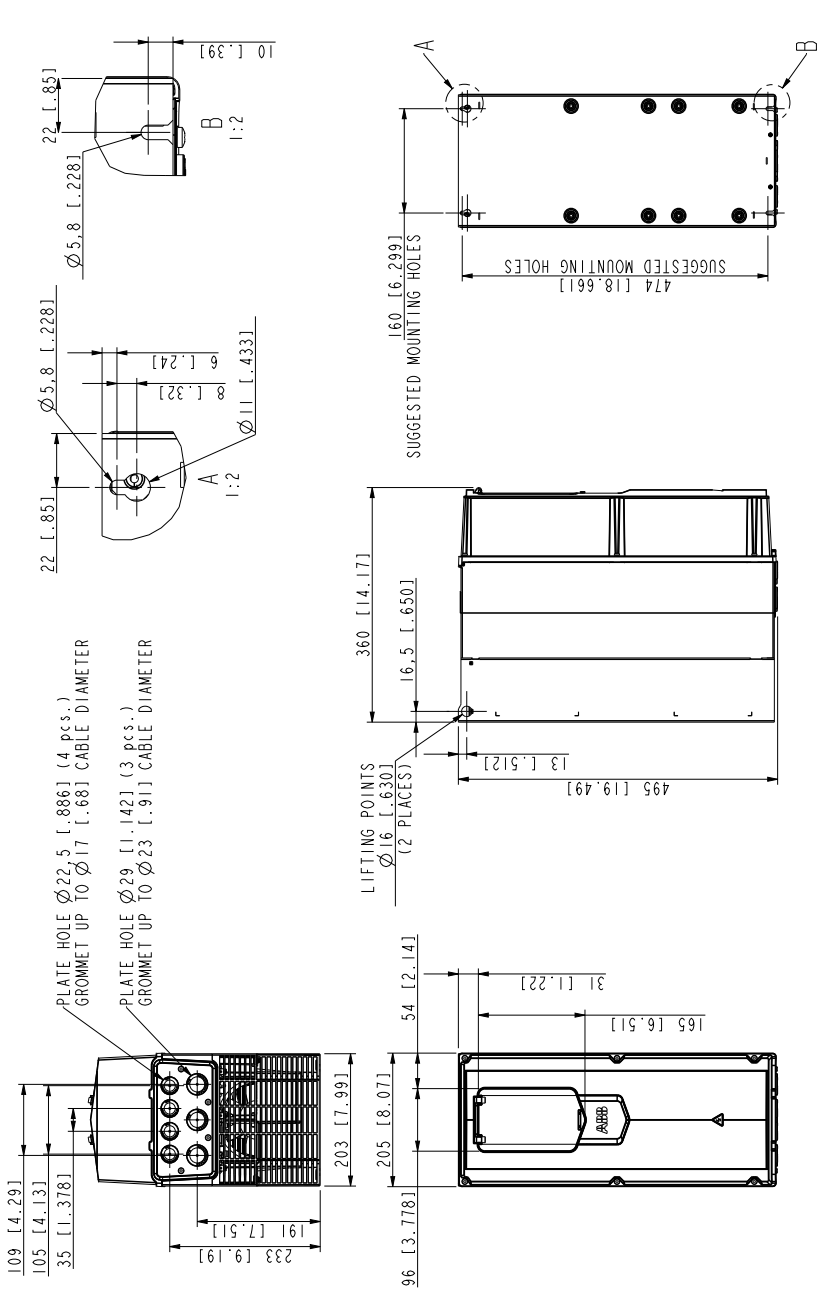

R6 – Option +B054 (IP55, UL Type 12)

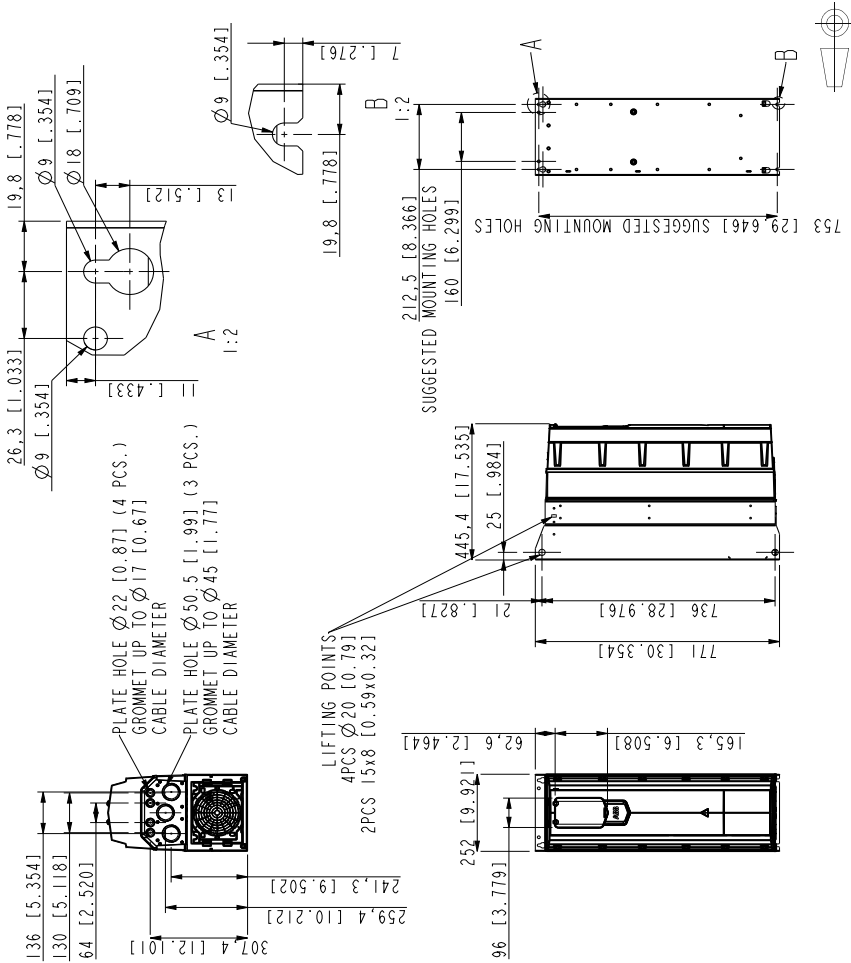

3AXD50000045352

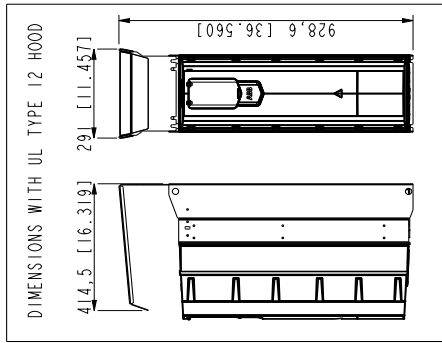

R6 – Option +B056 (IP55, UL Type 12)

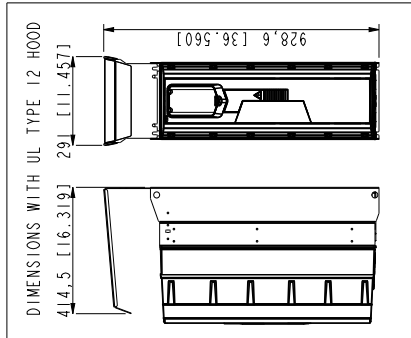
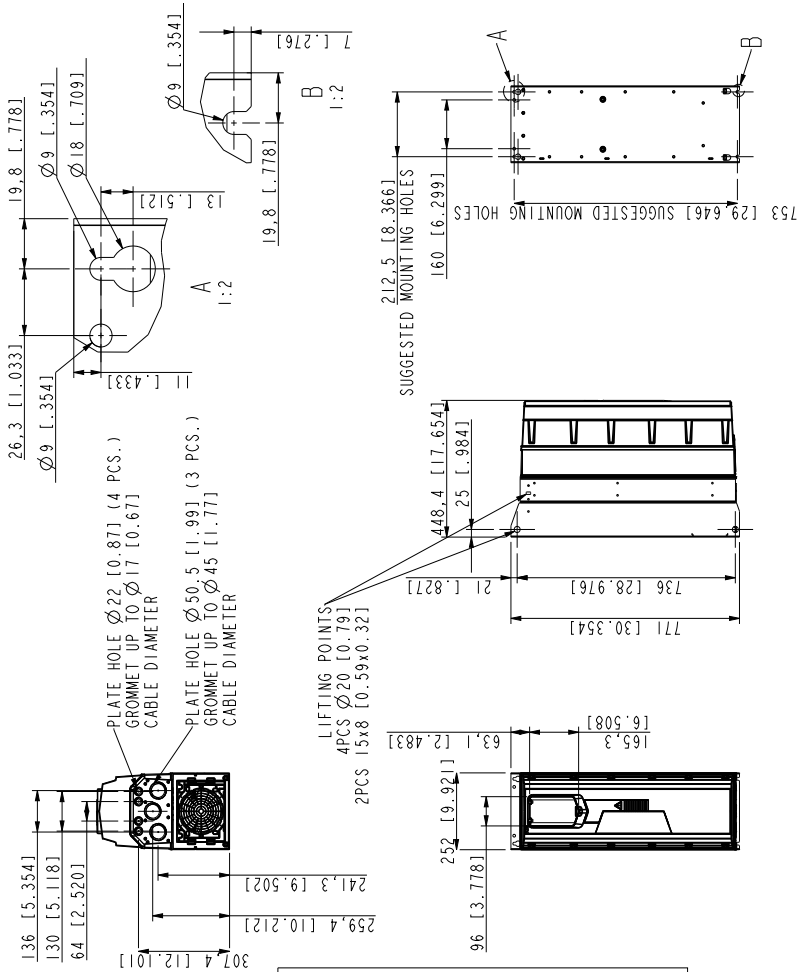

3AXD50000045351

R8, IP21 (UL Type 1)

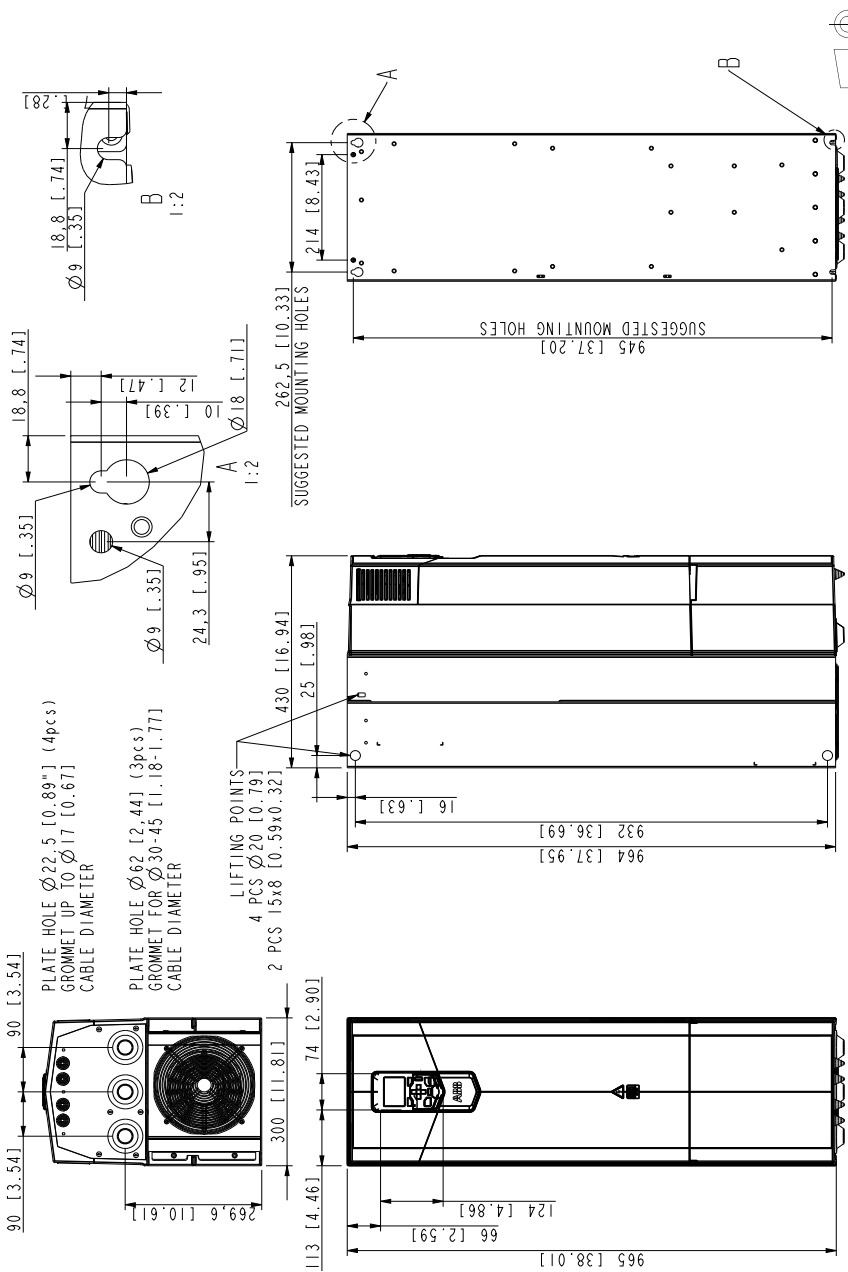

3AXD50000047667



13

The Safe torque off function

Contents of this chapter

This chapter describes the Safe torque off (STO) function of the drive and gives instructions for its use.

Description

The Safe torque off function can be used, for example, as the final actuator device of safety circuits that stop the drive in case of danger (such as an emergency stop circuit). Another typical application is a prevention of unexpected start-up function that enables short-time maintenance operations like cleaning or work on non-electrical parts of the machinery without switching off the power supply to the drive.

When activated, the Safe torque off function disables the control voltage of the power semiconductors of the drive output stage (A, see diagram on page [215](#)), thus preventing the drive from generating the torque required to rotate the motor. If the motor is running when Safe torque off is activated, it coasts to a stop.

The Safe torque off function has a redundant architecture, that is, both channels must be used in the safety function implementation. The safety data given in this manual is calculated for redundant use, and does not apply if both channels are not used.

The Safe torque off function of the drive complies with these standards:

Standard	Name
IEC 60204-1:2016 EN 60204-1:2006 + A1:2009 + AC:2010	<i>Safety of machinery – Electrical equipment of machines – Part 1: General requirements</i>
IEC 61326-3-1:2017	<i>Electrical equipment for measurement, control and laboratory use – EMC requirements – Part 3-1: Immunity requirements for safety-related systems and for equipment intended to perform safety-related functions (functional safety) – General industrial applications</i>
IEC 61508-1:2010	<i>Functional safety of electrical/electronic/programmable electronic safety-related systems – Part 1: General requirements</i>
IEC 61508-2:2010	<i>Functional safety of electrical/electronic/programmable electronic safety-related systems – Part 2: Requirements for electrical/electronic/programmable electronic safety-related systems</i>
IEC 61511-1:2016	<i>Functional safety – Safety instrumented systems for the process industry sector</i>
IEC 61800-5-2:2016 EN 61800-5-2:2007	<i>Adjustable speed electrical power drive systems – Part 5-2: Safety requirements – Functional</i>
IEC 62061:2005 + A1:2012 + A2:2015 EN 62061:2005 + AC:2010 + A1:2013 + A2:2015	<i>Safety of machinery – Functional safety of safety-related electrical, electronic and programmable electronic control systems</i>
EN ISO 13849-1:2015	<i>Safety of machinery – Safety-related parts of control systems – Part 1: General principles for design</i>
EN ISO 13849-2:2012	<i>Safety of machinery – Safety-related parts of control systems – Part 2: Validation</i>

The function also corresponds to Prevention of unexpected start-up as specified by EN 1037:1995 + A1:2008 and Uncontrolled stop (stop category 0) as specified in EN/IEC 60204-1.

■ Compliance with the European Machinery Directive

See section [Compliance with the European Machinery Directive](#) on page 194.

Wiring

The following diagrams show examples of Safe torque off wiring for

- a single drive (page [215](#))
- multiple drives (page [216](#))
- multiple drives when an external 24 V power supply is used (page [217](#))

For drives with option +L537+Q971, see *ATEX-certified Safe disconnection function, Ex II (2) GD for ACS880 drives (option +Q971) application guide (3AUA0000074343 [English] and FPTC-02 ATEX-certified thermistor relay module, Ex II (2) GD (+L537+Q971) for ACS880 drives user's manual (3AXD5000027782 [English])*

For information on the specifications of the STO input, see section [Technical data](#) on page [100](#).

■ **Single drive (internal power supply)**

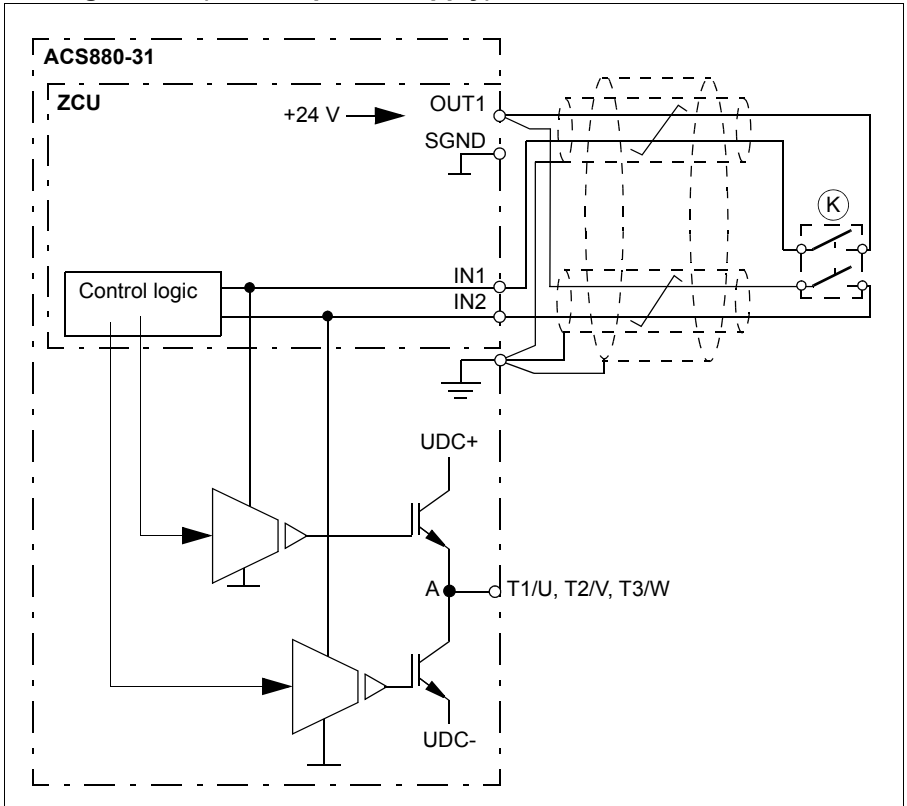

■ Multiple drives (internal power supply)

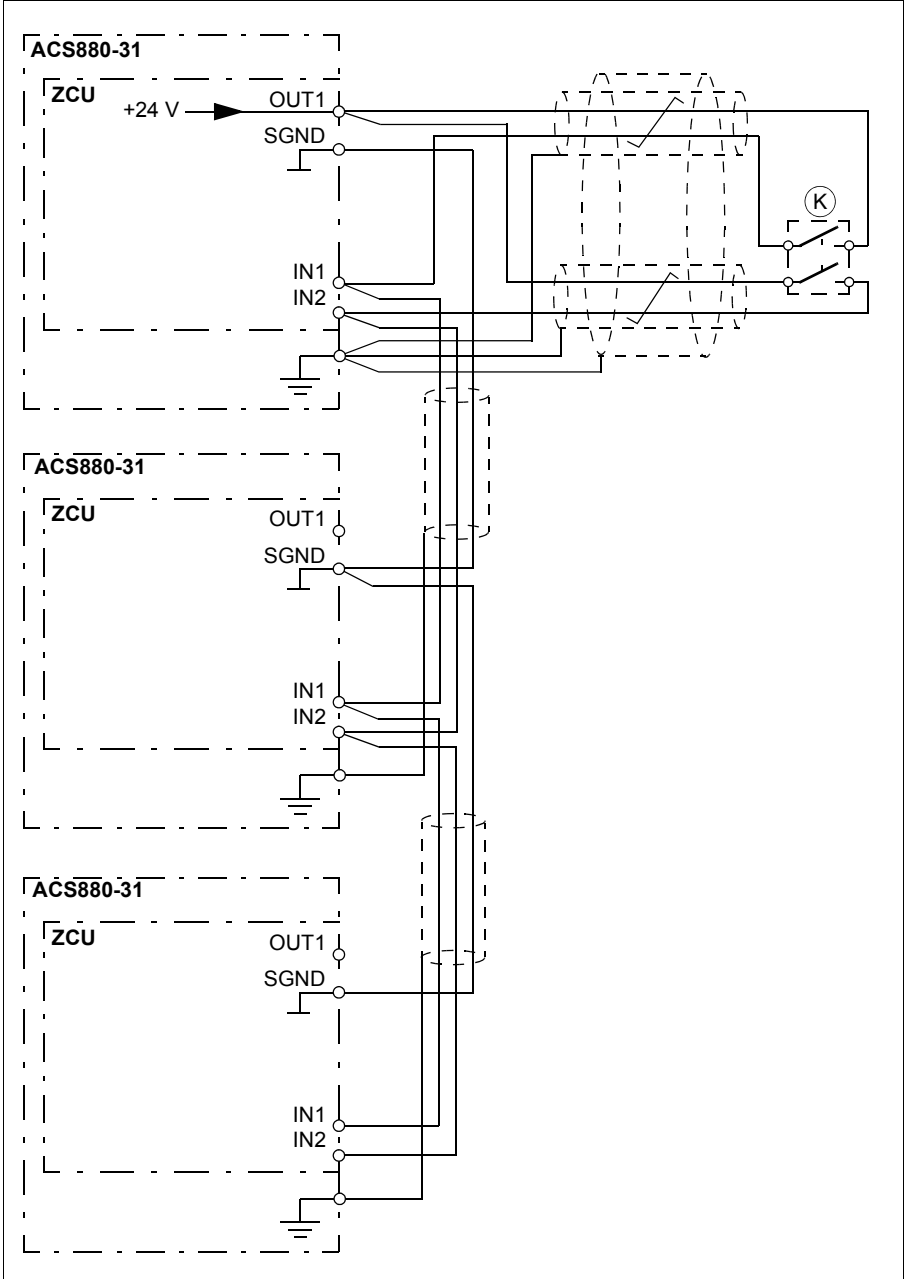

Multiple drives (external power supply)

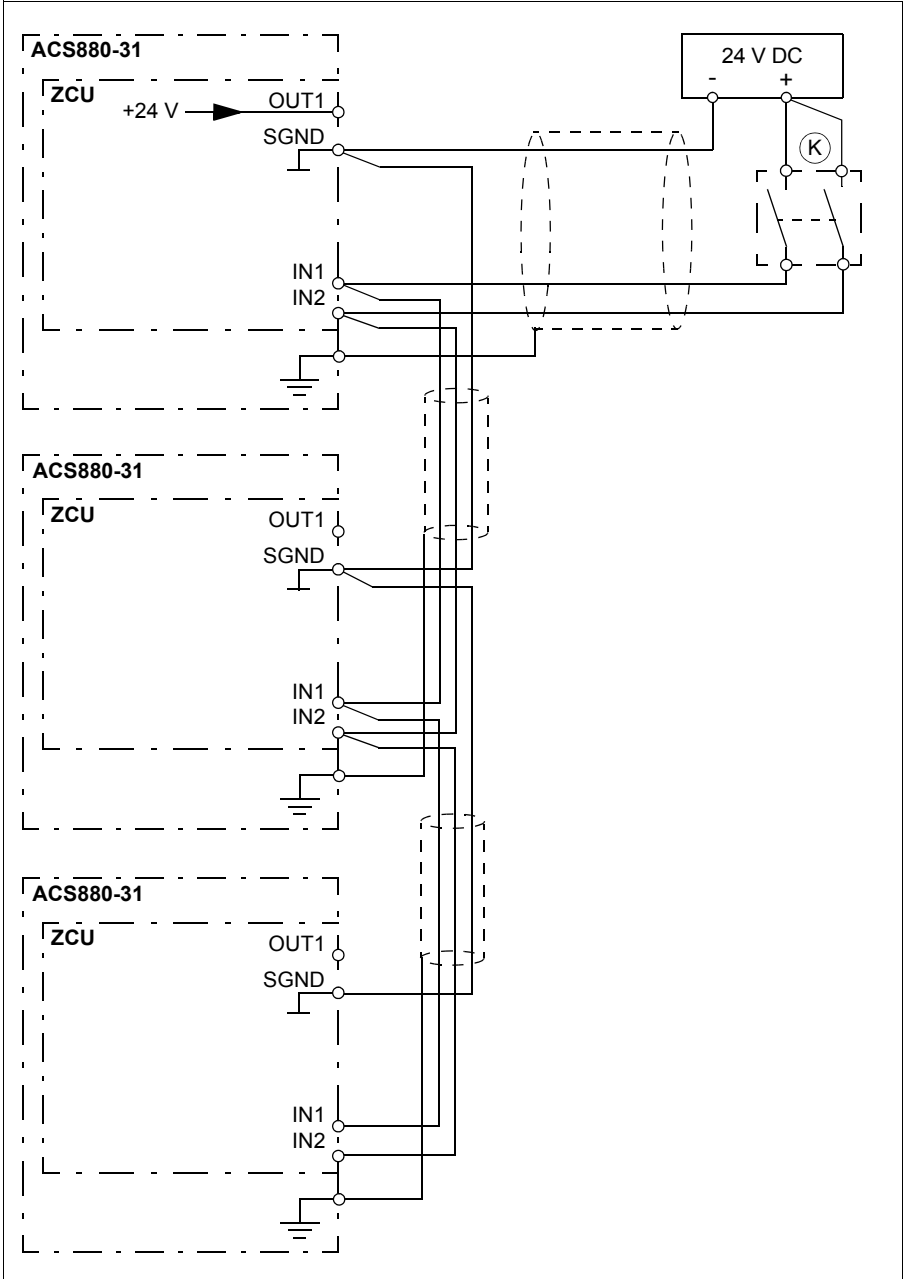

Wiring examples

■ Activation switch

In the wiring diagrams above (page 215), the activation switch has the designation (K). This represents a component such as a manually operated switch, an emergency stop push button switch, or the contacts of a safety relay or safety PLC.

- If a manually operated activation switch is used, the switch must be of a type that can be locked out to the open position.
- The contacts of the switch or relay must open/close within 200 ms of each other.
- An FSO-xx safety functions module or an FPTC-0x thermistor protection module can also be used. For more information, see the module documentation.

■ Cable types and lengths

- Double-shielded twisted-pair cable is recommended.
- Maximum cable length
 - 300 m (1000 ft) between activation switch (K) and drive control unit
 - 60 m (200 ft) between multiple drives
 - 60 m (200 ft) between external power supply and first drive.

Note: The voltage at the INx terminals of the control unit must be at least 17 V DC to be interpreted as “1”.

■ Grounding of protective shields

- Ground the shield in the cabling between the activation switch and the control unit at the control unit.
- Ground the shield in the cabling between two control units at one control unit only.

Operation principle

1. The Safe torque off activates (the activation switch is opened, or safety relay contacts open).
 2. The STO inputs on the drive control unit de-energize.
 3. The control unit cuts off the control voltage from the output IGBTs.
 4. The control program generates an indication as defined by parameter 31.22 (refer to the firmware manual of the drive).
 5. The motor coasts to a stop (if running). The drive cannot restart while the activation switch or safety relay contacts are open. After the contacts close, a reset may be needed (depending on the setting of parameter 31.22). A new start command is required to start the drive.
-

Start-up including acceptance test

To ensure the safe operation of a safety function, validation is required. The final assembler of the machine must validate the function by performing an acceptance test. The acceptance test must be performed

- at initial start-up of the safety function
- after any changes related to the safety function (circuit boards, wiring, components, settings, etc.)
- after any maintenance work related to the safety function.

■ Competence

The acceptance test of the safety function must be carried out by a competent person with adequate expertise and knowledge of the safety function as well as functional safety, as required by IEC 61508-1 clause 6. The test procedures and report must be documented and signed by this person.

■ Acceptance test reports

Signed acceptance test reports must be stored in the logbook of the machine. The report shall include documentation of start-up activities and test results, references to failure reports and resolution of failures. Any new acceptance tests performed due to changes or maintenance shall be logged into the logbook.

■ Acceptance test procedure

After wiring the Safe torque off function, validate its operation as follows.

Note: If the drive is equipped with safety option +Q972, +Q973 or +Q982, do the procedure shown in the FSO module documentation. If an FSO-xx safety functions module or an FPTC-0x module is installed, refer to its documentation.

Action	<input checked="" type="checkbox"/>
 WARNING! Follow the Safety instructions , page 13. If you ignore the instructions physical injury or death, or damage to the equipment can occur.	<input type="checkbox"/>
Ensure that the drive can be run and stopped freely during start-up.	<input type="checkbox"/>
Stop the drive (if running), switch the input power off and isolate the drive from the power line by a disconnecter.	<input type="checkbox"/>
Check the Safe torque off circuit connections against the wiring diagram.	<input type="checkbox"/>
Close the disconnecter and switch the power on.	<input type="checkbox"/>

<p>Action</p>	<input checked="" type="checkbox"/>
<p>Test the operation of the STO function when the motor is stopped.</p> <ul style="list-style-type: none"> • Give a stop command for the drive (if running) and wait until the motor shaft is at a standstill. <p>Ensure that the drive operates as follows:</p> <ul style="list-style-type: none"> • Open the STO circuit. The drive generates an indication if one is defined for the 'stopped' state in parameter 31.22 (see the firmware manual). • Give a start command to verify that the STO function blocks the drive's operation. The drive displays a warning. The motor should not start. • Close the STO circuit. • Reset any active faults. Restart the drive and check that the motor runs normally. 	<input type="checkbox"/>
<p>Test the operation of the STO function when the motor is running.</p> <ul style="list-style-type: none"> • Start the drive and ensure the motor is running. • Open the STO circuit. The motor should stop. The drive generates an indication if one is defined for the 'running' state in parameter 31.22 (see the firmware manual). • Reset any active faults and try to start the drive. • Ensure that the motor stays at a standstill and the drive operates as described above in testing the operation when the motor is stopped. • Close the STO circuit. • Reset any active faults. Restart the drive and check that the motor runs normally. 	<input type="checkbox"/>
<p>Test the operation of the failure detection of the drive. The motor can be stopped or running.</p> <ul style="list-style-type: none"> • Open the 1st channel of the STO circuit (wire coming to IN1). If the motor was running, it should coast to a stop. The drive generates a <i>FA81 Safe torque off 1 loss</i> fault indication (see the firmware manual). • Give a start command to verify that the STO function blocks the operation. The motor should not start. • Close the STO circuit. • Reset any active faults. Restart the drive and check that the motor runs normally. • Open the 2nd channel of the STO circuit (wire coming to IN2). If the motor was running, it should coast to a stop. The drive generates a <i>FA82 Safe torque off 2 loss</i> fault indication (see the firmware manual). • Give a start command to verify that the STO function blocks the operation. The motor should not start. • Close the STO circuit. • Reset any active faults. Restart the drive and check that the motor runs normally. 	<input type="checkbox"/>
<p>Document and sign the acceptance test report which verifies that the safety function is safe and accepted for operation.</p>	<input type="checkbox"/>

Use

1. Open the activation switch, or activate the safety functionality that is wired to the STO connection.
2. The STO inputs of the drive control unit de-energize, and the drive control unit cuts off the control voltage from the output IGBTs.
3. The control program generates an indication as defined by parameter 31.22 (refer to the firmware manual of the drive).
4. The motor coasts to a stop (if running). The drive will not restart while the activation switch or safety relay contacts are open.
5. Deactivate the STO by closing the activation switch, or resetting the safety functionality that is wired to the STO connection.
6. Reset any faults before restarting.



WARNING! The Safe torque off function does not disconnect the voltage of the main and auxiliary circuits from the drive. Therefore maintenance work on electrical parts of the drive or the motor can only be carried out after isolating the drive from the main supply.



WARNING! (With permanent magnet motors or synchronous reluctance [SynRM] motors only). In case of a multiple IGBT power semiconductor failure, the drive can produce an alignment torque which maximally rotates the motor shaft by $180/p$ degrees (with permanent magnet motors) or $180/2p$ degrees (with synchronous reluctance [SynRM] motors) regardless of the activation of the Safe torque off function. p denotes the number of pole pairs.

Notes:

- If a running drive is stopped by using the Safe torque off function, the drive will cut off the motor supply voltage and the motor will coast to a stop. If this causes danger or is not otherwise acceptable, stop the drive and machinery using the appropriate stop mode before activating the Safe torque off function.
 - The Safe torque off function overrides all other functions of the drive.
 - The Safe torque off function is ineffective against deliberate sabotage or misuse.
 - The Safe torque off function has been designed to reduce the recognized hazardous conditions. In spite of this, it is not always possible to eliminate all potential hazards. The assembler of the machine must inform the final user about the residual risks.
-

Maintenance

After the operation of the circuit is validated at start-up, the STO function shall be maintained by periodic proof testing. In high demand mode of operation, the maximum proof test interval is 20 years. In low demand mode of operation, the maximum proof test interval is 5 or 2 years; see section [Safety data \(SIL, PL\)](#) (page 223). It is assumed that all dangerous failures of the STO circuit are detected by the proof test. To perform the proof test, do the [Acceptance test procedure](#) (page 219).

Note: See also the Recommendation of Use CNB/M/11.050 (published by the European co-ordination of Notified Bodies) concerning dual-channel safety-related systems with electromechanical outputs:

- When the safety integrity requirement for the safety function is SIL 3 or PL e (cat. 3 or 4), the proof test for the function must be performed at least every month.
- When the safety integrity requirement for the safety function is SIL 2 (HFT = 1) or PL d (cat. 3), the proof test for the function must be performed at least every 12 months.

The STO function of the drive does not contain any electromechanical components.

In addition to proof testing, it is a good practice to check the operation of the function when other maintenance procedures are carried out on the machinery.

Include the Safe torque off operation test described above in the routine maintenance program of the machinery that the drive runs.

If any wiring or component change is needed after start up, or the parameters are restored, follow the test given in section [Acceptance test procedure](#) on page 219.

Use only ABB approved spare parts.

Record all maintenance and proof test activities in the machine logbook.

■ Competence

The maintenance and proof test activities of the safety function must be carried out by a competent person with adequate expertise and knowledge of the safety function as well as functional safety, as required by IEC 61508-1 clause 6.

Fault tracing

The indications given during the normal operation of the Safe torque off function are selected by parameter 31.22.

The diagnostics of the Safe torque off function cross-compare the status of the two STO channels. In case the channels are not in the same state, a fault reaction function is performed and the drive trips on an “STO hardware failure” fault. An attempt to use the STO in a non-redundant manner, for example activating only one channel, will trigger the same reaction.

See the drive firmware manual for the indications generated by the drive, and for details on directing fault and warning indications to an output on the control unit for external diagnostics.

Any failures of the Safe torque off function must be reported to ABB.

Safety data (SIL, PL)

The safety data for the Safe torque off function is given below.

Note: The safety data is calculated for redundant use, and does not apply if both STO channels are not used.

Frame size	SIL/ SILCL	PL	SFF (%)	PFH (T ₁ = 20 a) (1/h)	PFD _{avg} (T ₁ = 2 a)	PFD _{avg} (T ₁ = 5 a)	MTTF _D (a)	DC (%)	Cat.	SC	HFT	CCF	Life-time (a)
<i>U_N</i> = 400 V, <i>U_N</i> = 500 V													
R3	3	e	99.2	3.14E-09	2.62E-05	6.56E-05	10321	≥90	3	3	1	80	20
R6	3	e	99.4	3.15E-09	2.62E-05	6.56E-05	10122	≥90	3	3	1	80	20
R8	3	e	99.1	3,20E-09	2,66E-05	6,65E-05	10333	≥90	3	3	1	80	20

R3 and R6: 3AXD10000606249 A, R8: 3AXD1000006217 G

- The following temperature profile is used in safety value calculations:
 - 670 on/off cycles per year with $\Delta T = 71.66\text{ }^{\circ}\text{C}$
 - 1340 on/off cycles per year with $\Delta T = 61.66\text{ }^{\circ}\text{C}$
 - 30 on/off cycles per year with $\Delta T = 10.0\text{ }^{\circ}\text{C}$
 - 32 °C board temperature at 2.0% of time
 - 60 °C board temperature at 1.5% of time
 - 85 °C board temperature at 2.3% of time.
- The STO is a type A safety component as defined in IEC 61508-2.
- Relevant failure modes:
 - The STO trips spuriously (safe failure)
 - The STO does not activate when requested

A fault exclusion on the failure mode “short circuit on printed circuit board” has been made (EN 13849-2, table D.5). The analysis is based on an assumption that one failure occurs at one time. No accumulated failures have been analyzed.
- STO reaction time (shortest detectable break): 1 ms
- STO response time: 2 ms (typical), 5 ms (maximum)
- Fault detection time: Channels in different states for longer than 200 ms
- Fault reaction time: Fault detection time + 10 ms
- STO fault indication (parameter 31.22) delay: < 500 ms
- STO warning indication (parameter 31.22) delay: < 1000 ms

■ Abbreviations

Abbr.	Reference	Description
Cat.	EN ISO 13849-1	Classification of the safety-related parts of a control system in respect of their resistance to faults and their subsequent behavior in the fault condition, and which is achieved by the structural arrangement of the parts, fault detection and/or by their reliability. The categories are: B, 1, 2, 3 and 4.
CCF	EN ISO 13849-1	Common cause failure (%)
DC	EN ISO 13849-1	Diagnostic coverage
HFT	IEC 61508	Hardware fault tolerance
MTTF _D	EN ISO 13849-1	Mean time to dangerous failure: (Total number of life units) / (Number of dangerous, undetected failures) during a particular measurement interval under stated conditions
PF _D _{avg}	IEC 61508	Average probability of dangerous failure on demand, that is, mean unavailability of a safety-related system to perform the specified safety function when a demand occurs
PFH	IEC 61508	Average frequency of dangerous failures per hour, that is, average frequency of a dangerous failure of a safety related system to perform the specified safety function over a given period of time
PL	EN ISO 13849-1	Performance level. Levels a...e correspond to SIL
SC	IEC 61508	Systematic capability
SFF	IEC 61508	Safe failure fraction (%)
SIL	IEC 61508	Safety integrity level (1...3)
SILCL	IEC/EN 62061	Maximum SIL (level 1...3) that can be claimed for a safety function or subsystem
STO	IEC/EN 61800-5-2	Safe torque off
T ₁	IEC 61508-6	Proof test interval. T ₁ is a parameter used to define the probabilistic failure rate (PFH or PFD) for the safety function or subsystem. Performing a proof test at a maximum interval of T ₁ is required to keep the SIL capability valid. The same interval must be followed to keep the PL capability (EN ISO 13849) valid. Note that any T ₁ values given cannot be regarded as a guarantee or warranty. See also section Maintenance (page 222).

14

Resistor braking

Contents of this chapter

The chapter describes the resistor braking. how to select, protect and wire external brake choppers and brake resistors for the drive. The chapter also contains installation instructions and the technical data.

Operation principle and hardware description

The brake chopper handles the energy generated by a decelerating motor. The chopper connects the brake resistor to the intermediate DC circuit whenever the voltage in the circuit exceeds the limit defined by the control program. Energy consumption by the resistor losses lowers the voltage until the resistor can be disconnected.

Planning the braking system

The drive needs external brake chopper and resistors. The table below lists suitable choppers and resistors. Other resistors can also be used as long as the minimum resistance value and required power values are met.

■ Selecting the brake circuit components

1. Calculate the maximum power generated by the motor during braking (P_{\max}).
 2. Select a suitable drive, brake chopper and brake resistor combination for the application from the rating table on page [230](#). The braking power of the chopper must be greater or equal than the maximum power generated by the motor during the braking.
 3. Check the resistor selection. The energy generated by the motor during a 400-second period must not exceed the resistor heat dissipation capacity E_R .
-

Note: If the E_R value is not sufficient, it is possible to use a four-resistor assembly in which two standard resistors are connected in parallel, two in series. The E_R value of the four-resistor assembly is four times the value specified for the standard resistor.

■ Selecting a custom resistor

If you use a resistor other than the default resistor, make sure that:

1. The resistance of the custom resistor is greater or equal than the resistance of the default resistor in the rating table on page 230:

$$R \geq R_{\min}$$

where

R Resistance of the custom resistor.



WARNING! Never use a brake resistor with a resistance smaller than R_{\min} . The drive and the chopper are not able to handle the overcurrent caused by the low resistance.

R_{\min} Resistance of the default resistor

2. The load capacity of the custom resistor is higher than the instantaneous maximum power consumption of the resistor when it is connected to the drive DC link voltage by the chopper:

$$P_r < \frac{U_{DC}^2}{R}$$

where

P_r Load capacity of the custom resistor

U_{DC} Drive DC link voltage.

1.35 · 1.25 · 415 V DC (when supply voltage is 380 to 415 V AC)

1.35 · 1.25 · 500 V DC (when supply voltage is 440 to 500 V AC) or

R Resistance of the custom resistor

■ Selecting and routing the brake resistor cables

Use the same cable type for the resistor cabling as for the drive input cabling to ensure that the input fuses also protect the resistor cable. Alternatively, a two conductor shielded cable with the same cross-sectional area can be used.

Minimizing electromagnetic interference

Follow these rules in order to minimize electromagnetic interference caused by the rapid current changes in the resistor cables:

- Shield the braking power line completely, either by using shielded cable or a metallic enclosure. Unshielded single-core cable can only be used if it is routed inside a cabinet that efficiently suppresses the radiated emissions.
- Install the cables away from other cable routes.
- Avoid long parallel runs with other cables. The minimum parallel cabling separation distance should be 0.3 meters.
- Cross the other cables at right angles.
- Keep the cable as short as possible in order to minimize the radiated emissions and stress on chopper IGBTs. The longer the cable the higher the radiated emissions, inductive load and voltage peaks over the IGBT semiconductors of the brake chopper.

Maximum cable length

The maximum length of the resistor cable(s) is 10 m (33 ft).

EMC compliance of the complete installation

Note: ABB has not verified that the EMC requirements are fulfilled with external user-defined brake resistors and cabling. The EMC compliance of the complete installation must be considered by the customer.

■ Placing the brake resistors

Install the resistors outside the drive in a place where they will cool.

Arrange the cooling of the resistor in a way that:

- no danger of overheating is caused to the resistor or nearby materials
- the temperature of the room the resistor is located in does not exceed the allowed maximum.

Supply the resistor with cooling air/water according to the resistor manufacturer's instructions.



WARNING! The materials near the brake resistor must be non-flammable. The surface temperature of the resistor is high. Air flowing from the resistor is of hundreds of degrees Celsius. If the exhaust vents are connected to a ventilation system, ensure that the material withstands high temperatures. Protect the resistor against contact.

■ Protecting the system against thermal overload

The brake chopper protects itself and the resistor cables against thermal overload when the cables are dimensioned according to the nominal current of the drive. The drive control program includes a resistor and resistor cable thermal protection function which can be tuned by the user. See the firmware manual.

■ Protecting the system in fault situations

Equip the drive with a main contactor and the resistor with a thermal switch ([1] in the wiring example below). Wire the contactor so that it opens in case the resistor overheats. Connect the thermal switch to the disconnect circuit. This is essential for safety since the drive will not otherwise be able to interrupt the main supply if the chopper remains conductive in a fault situation.

An example wiring diagram is shown below.

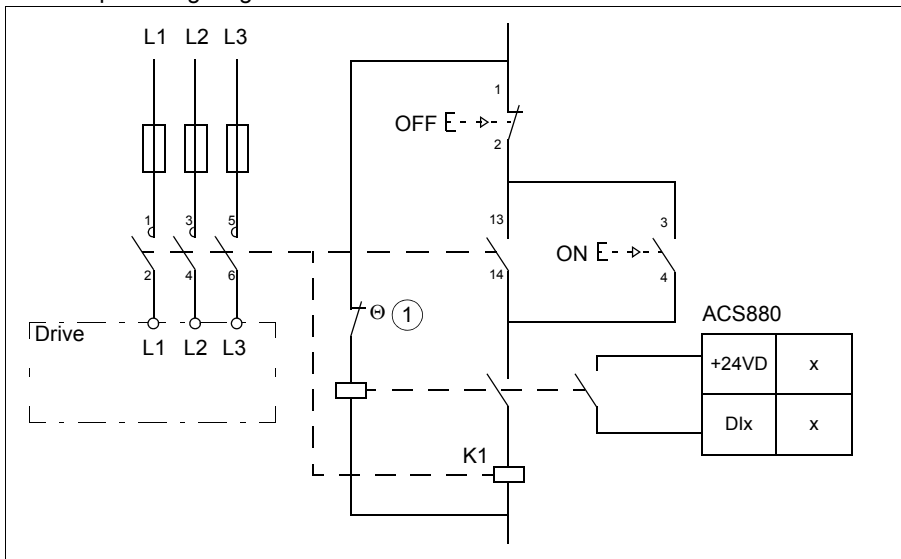

1 Thermal switch

The thermal switch cable must be shielded and may not be longer than the resistor cable. ABB recommends that you also wire the thermal switch to a digital input on the drive.

ABB resistors are equipped with a thermal switch inside the resistor assembly as standard. The switch indicates overtemperature and overload. ABB recommends that you wire the thermal switch to a digital input of the drive.

■ Protecting the resistor cable against short-circuits

The input fuses will also protect the resistor cable when it is identical with the input cable.

Mechanical installation

The brake chopper and brake resistors must be installed outside the drive. Obey the resistor manufacturer's instructions.

Electrical installation

■ Checking the insulation of the assembly

Follow the instructions given under [Brake resistor assembly](#) on page 77.

■ Connection diagram

See section [Connection diagram](#) on page 85.

■ Connection procedure

Connect the brake chopper the DC+ and DC- terminals of the drive. Connect the resistor cables to the brake chopper as described in the brake chopper manual. If a shielded three-conductor cable is used, cut the third conductor, insulate it, and ground the twisted shield of the cable (protective earth conductor of the resistor assembly) at both ends.

Start-up

Note: Protective oil on the brake resistors will burn off when the brake resistor is used for the first time. Make sure that the airflow is sufficient.

Set the following parameters (ACS880 primary control program):

- Disable the overvoltage control of the drive by parameter **30.30 Overvoltage control**.
- Set parameter **31.01 External event 1 source** to point to the digital input where the thermal switch of the brake resistor is wired.
- Set parameter **31.02 External event 1 type** to **Fault**.

For settings of other control programs, see the appropriate firmware manual.



WARNING! Parameter 95.07 LCU DC REF (V) must be set to the minimum value (default) with brake resistors. Otherwise energy from the supply network can flow to the brake resistor causing overheating of the resistor and damage to the equipment.

Technical data

■ Ratings

Contact ABB for the brake chopper and resistor specifications.

■ Terminals and cable lead-through data

See section [Terminal and entry data for the power cables](#) on page 181.

15

Common mode, du/dt and sine filters

Contents of this chapter

This chapter describes how to select external filters for the drive.

Common mode filters

■ When is a common mode filter needed?

See section [Checking the compatibility of the motor and drive](#), page 52. Common mode filter kits are available from ABB with order number 64315811. A kit includes three wound cores. For installation instructions of the cores, see the instruction included in the kit package.

du/dt filters

■ When is a du/dt filter needed?

See section [Checking the compatibility of the motor and drive](#), page 52.

du/dt filter types

Type ACS880 -31-	du/dt filter type	Type ACS880 -31-	du/dt filter type
$U_N = 400\text{ V}$		$U_N = 500\text{ V}$	
09A4-3	NOCH0016-6X	07A6-5	NOCH0016-6X
12A6-3	NOCH0016-6X	11A0-5	NOCH0016-6X
017A-3	NOCH0030-6X	014A-5	NOCH0030-6X
025A-3	NOCH0030-6X	021A-5	NOCH0030-6X
032A-3	NOCH0070-6X	027A-5	NOCH0070-6X
038A-3	NOCH0070-6X	034A-5	NOCH0070-6X
045A-3	NOCH0070-6X	040A-5	NOCH0070-6X
061A-3	NOCH0070-6X	052A-5	NOCH0070-6X
072A-3	NOCH0120-6X	065A-5	NOCH0120-6X
087A-3	NOCH0120-6X	077A-5	NOCH0120-6X
105A-3	NOCH0120-6X	101A-5	NOCH0120-6X
145A-3	FOCH0260-70	124A-5	FOCH0260-7X
169A-3	FOCH0260-70	156A-5	FOCH0260-7X
206A-3	FOCH0260-70	180A-5	FOCH0260-7X

3AXD00000588487

Description, installation and technical data of the NOCH filters

See *AOCH and NOCH du/dt filters hardware manual* (3AFE58933368 [English]).

Sine filters

Selecting a sine filter for the drive

The table below lists the preselected sine filters by Epcos.

Type ACS880 -31-	Sine filter type	$I_{\text{cont. max}}$	$P_{\text{cont. max}}$	Heat dissipation			Noise
				Drive	Filter	Total	
		A	kW	W	W	W	dB(A)
$U_N = 400\text{ V}$							
09A4-3	B84143V0011R229	10,0	4,0	122	90	212	72
12A6-3	B84143V0016R229	12,9	5,5	172	80	252	72
017A-3	B84143V0025R229	17	7,5	232	140	372	75
025A-3	B84143V0025R229	25	11,0	337	140	477	75
032A-3	B84143V0033R229	32	15,0	457	160	617	75
038A-3	B84143V0050R229	38	18,5	562	220	782	78
045A-3	B84143V0050R229	45	22,0	667	220	887	78

Type ACS880 -31-	Sine filter type	$I_{\text{cont. max}}$	$P_{\text{cont. max}}$	Heat dissipation			Noise dB(A)
				Drive	Filter	Total	
		A	kW	W	W	W	
061A-3	B84143V0066R229	61	30,0	907	250	1157	78
072A-3	B84143V0075R229	72	37,0	1117	310	1427	79
087A-3	B84143V0095R229	87	45,0	1120	400	1520	79
105A-3	B84143V0130S230	105	55,0	1295	600	1895	80
145A-3	B84143V0162S229	145	75,0	1440	550	1990	80
169A-3	B84143V0162S229	169	90,0	1940	550	2490	80
206A-3	B84143V0230S229	206	110,0	2310	900	3210	80
$U_N = 500 \text{ V}$							
07A6-5	B84143V0011R229	7,6	4,0	122	90	212	72,0
11A0-5	B84143V0011R229	11,0	5,5	172	90	262	72,0
014A-5	B84143V0016R229	14	7,5	232	80	312	70
021A-5	B84143V0025R229	21	11,0	337	140	477	75
027A-5	B84143V0033R229	27	15,0	457	160	617	75
034A-5	B84143V0050R229	34	18,5	562	220	782	78
040A-5	B84143V0050R229	40	22,0	667	220	887	78
052A-5	B84143V0066R229	52	30,0	907	250	1157	78
065A-5	B84143V0066R229	65	37,0	1117	250	1367	78
077A-5	B84143V0075R229	77	37,0	1120	310	1430	78
101A-5	B84143V0130S230	96	55,0	1295	630	1925	80
124A-5	B84143V0130S230	124	55,0	1440	630	2070	80
158A-5	B84143V0162S229	156	90,0	1940	550	2490	80
180A-5	B84143V0162S229	180	110,0	2310	550	2860	80

3AXD00000588487

Definitions

$P_{\text{cont.max}}$	Maximum continuous output power of the drive
$I_{\text{cont.max}}$	Maximum continuous output current of the drive
Noise	Noise level of the sine filter

Derating

See section [Deratings for special settings in the drive control program](#) on page 169.

■ Description, installation and technical data

For the filter data sheets, go to <http://en.tdk.eu/>. See also *Sine filters hardware manual* (3AXD50000016814 [English])

Further information

Product and service inquiries

Address any inquiries about the product to your local ABB representative, quoting the type designation and serial number of the unit in question. A listing of ABB sales, support and service contacts can be found by navigating to www.abb.com/searchchannels.

Product training

For information on ABB product training, navigate to new.abb.com/service/training.

Providing feedback on ABB Drives manuals

Your comments on our manuals are welcome. Navigate to new.abb.com/drives/manuals-feedback-form.

Document library on the Internet

You can find manuals and other product documents in PDF format on the Internet at www.abb.com/drives/documents.

Contact us

www.abb.com/drives

www.abb.com/drivespartners

3AXD50000045933 Rev C (EN) EFFECTIVE: 2018-06-25